

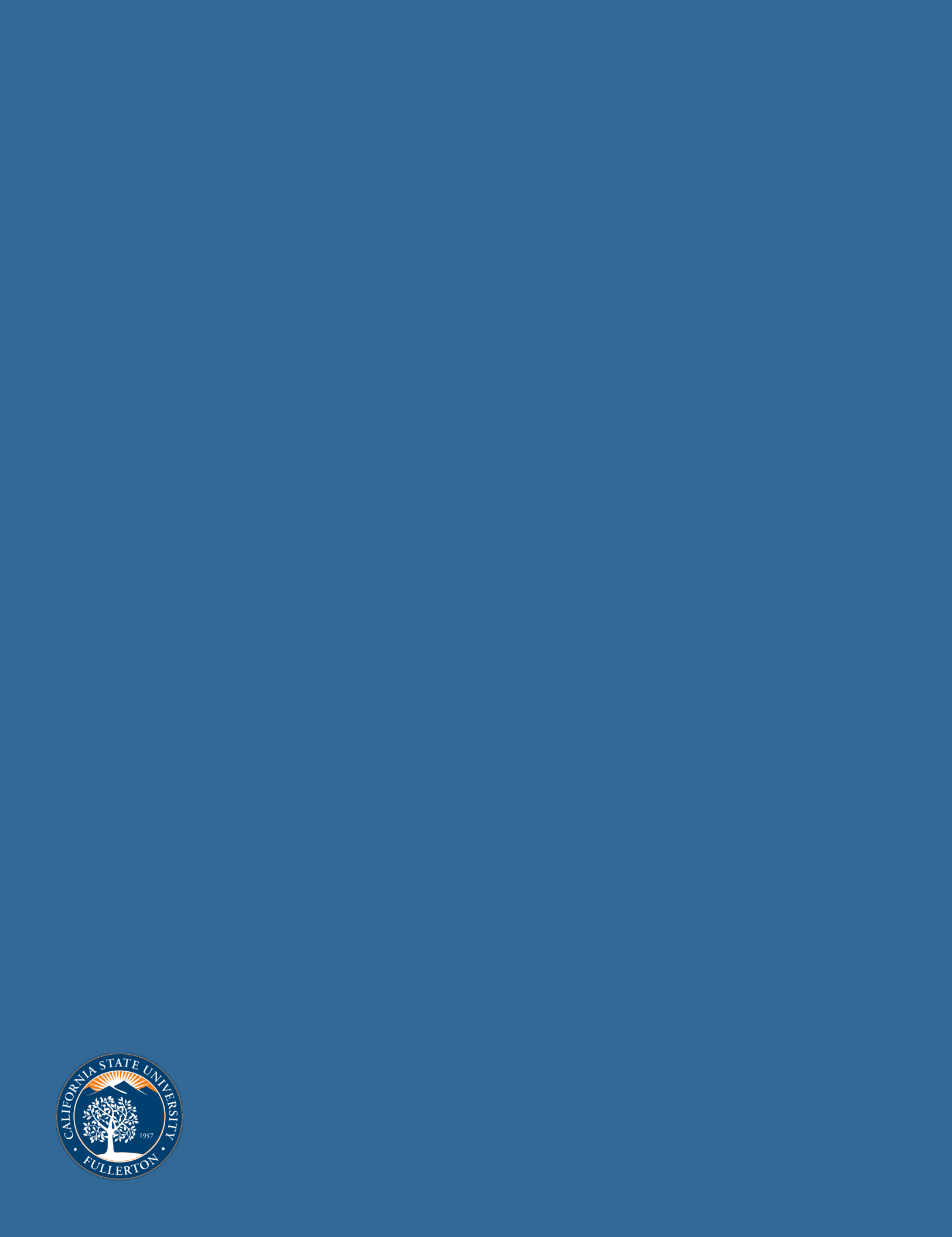
# Physical Master Plan

*California State University, Fullerton*  
2020-2039

Issued: March 2020









## LETTER FROM THE PRESIDENT

It is my pleasure to invite you to explore our Physical Master Plan. In it you will find the pathway for change that will transform our campus over the next 20 years while holding true to the values, the vision and the pride we all feel are foundational to our Titan way. This Physical Master Plan follows the last effort made for the campus in 2003 and, importantly, falls on the heels of our recently updated Strategic Plan. It fulfills our obligation to the state and the CSU System to update our intentions as a university. It comes at a pivotal moment in our history as we, like so many others in the higher education community, face formational challenges and opportunities on many fronts.

Our campus has grown from very modest beginnings to what is now a vibrant community of approximately 40,000 students, faculty and staff engaged in a broad spectrum of scholarship and activities, all aimed at generating outstanding graduates and promoting the benefits of lifelong learning. But we also play a broader role in our community through our stewardship of a world-class arboretum, our contributions to the arts community, our partnerships with businesses and industries that find value in our work and through the variety of student organizations and athletics that bring richness to everyday life.

We are constantly seeking to increase our relevance and strength for the benefit of our students and their families. This master planning effort has provided another avenue to identify opportunities to do just that. This is not a master plan that simply locates future buildings and pathways for the campus, although we do deliver those and more.

There are five interconnected areas of focus which guided the master planning effort: Learning, Connection, Values, Identity, and Activation. Through our work, we have set out goals for the master plan that are aspirational, operational and experiential in nature:

- Provide for our growth at the rate of 1 percent/year as developed in conjunction with the planning efforts of the CSU Campus System;
- Create a campus setting that can host the future of higher education with greater flexibility and a physical framework that can be realized over time in response to our ever-evolving needs;

- Compose a campus setting that can support efforts to improve our graduation rates;
- Refocus the future of academic space to allow for problem-based learning and to host research as learning for more of our students;
- Provide settings, formal and informal, that embrace cross-disciplinary collaboration and increase the quality of our student-to-student and student-to-faculty interactions, helping everyone feel the benefits of connection and support; and
- Strengthen our abilities to connect to and increase support from our neighbors, the residents of the greater LA communities and the many partners and friends that have been a part of our success.

We arrived at these goals through extensive listening and dialogue in a variety of settings, using tools and methods that made it easy to gain feedback from students, faculty and staff, and our neighbors. These insights were the basis for dialogue with an Executive Task Force developed for this effort and were finally debated at the Cabinet level of the University. We held discussions with the CSU System's Office of the Chancellor along the way to ensure that the necessary questions and directions they seek from every campus were addressed.

Over the course of the past two years we have examined strategies and alternative approaches to develop the campus toward meeting its goals. Ultimately, we settled on one option that we believe serves our future best. It is flexible, and we expect it will be implemented through incremental action, starting with improvements that will be felt immediately by the Titan community.

Highlights for the Physical Master Plan include:

- Increasing residential options on campus to better support them with the lifestyle services and amenities that living on campus requires every day, thereby advancing their academic success;
- Accommodating program growth and change and increasing density of academic space at the campus core while enabling cross disciplinary learning and research;

- Creating an Innovation Hub that extends every student's learning experience by allowing them to think creatively and critically about how to apply what they have learned, creating prototypical products and processes relevant to everyday life in all sectors of our society;
- Establishing an Event Center, that will be used daily, not intermittently, for a wider variety of purposes in support of the entire campus;
- Restoring the Green Loop, an historic pathway that circumnavigates the campus and provides an organizing strategy for positioning a variety of clusters and open spaces in the future; even using it as a teaching tool for many of the programs on campus;
- Developing campus courtyards and greens, pathways and connections that extend building activities outdoors and creating landscapes that support outdoor living inherent to our Orange County way of life;
- Preserving our Arboretum as we resume primary responsibility for its management with ambitions for its improved use for academic purposes as well as protecting it as an important venue for seeking out solitude and reflection, both part of promoting well-being for campus and community residents alike;
- Composing an approach for transportation and parking that is aligned with our values for sustainable living by promoting greater use of alternative access to campus and setting policies that limit the increase of cars coming onto campus;
- Correcting infrastructure so as to better handle the episodic flooding we have experienced in the past with drainage features that can better manage those occurrences; and
- Setting resilience features into the plan that anticipate potential events, serving to protect our campus community.

There are many more aspects to this plan than I mention here and that I hope you will take the time to explore. Suffice it to say that we are excited to now start taking the steps necessary to achieve these with the full belief that we will continue to provide great value to our students, to sustain and grow our presence in the community and help create an ever improving quality of life for all Californians. This Physical Master Plan plays an important role as our Titan family continually aims to reach higher.

Sincerely,



Framroze Virjee  
President







## ACKNOWLEDGMENTS

### CABINET

**Framroze Virjee**, *President*

**Amir H. Dabirian** '84, '88, *VP for Information Technology*

**Jim Donovan**, *Director of Athletics*

**David Forgues**, *Vice President for Human Resources, Diversity & Inclusion*

**Danielle García**, *Chief of Staff*

**Gaelle H. Gralnek**, *University Counsel*

**Danny C. Kim**, *VP for Administration & Finance/CFO*

**Harry Le Grande**, *VP for Student Affairs*

**Pamella Oliver** '94, *Provost & VP for Academic Affairs*

**Gregory J. Saks**, *VP for University Advancement*

### TASK FORCE

**Danny Kim**, *Chair, VP for Administration & Finance/CFO*

**Matt Olson**, *Deputy Chief of Staff & Director of Executive Communications*

**Alyssa Adamson**, *Senior Director of Academic Finances and Space Management*

**Rob Scialdone**, *Budget Manager for the Division of Student Affairs*

**Tara Garcia**, *COO for Human Resources Services*

**Berhanu Tadesse**, *Assoc. VP for IT/Infrastructure Services*

**Tami Bui**, *Assoc. VP for Government & Community Relations*

**Mark Stohs**, *Academic Senate Chair, Professor of Finance*

**Deepak Sharma**, *Faculty Representative*

**Aaron Aguilar**, *Student Representative/ASI*

**Jim Donovan**, *Director of Athletics*

**Carol McDoniel**, *Director of Administration for ASI*

**Jenni Brundage**, *Director, Housing & Residential Engagement*

**Chuck Kissel**, *ED of ASC*

**Gregory Dymont**, *Director of the Fullerton Arboretum*

**Monique Shay/Gaelle Gralnek**, *Legal Counsel*

**Morteza Rahmatian**, *Dean - Mihaylo College of Business & Economics*

**Theresa Harvey**, *President & CEO of North Orange County Chamber*

**Matt Foulkes**, *Director of Community Development, City of Fullerton*

**Martin Grant**, *University Planner/Project Manager, Chancellor's Office*

**Ali Izadian**, *Assoc. VP for Capital Programs & Facilities Management*

**Sarab Singh**, *Director of Construction Management*

**Tuan Nguyen**, *Director of Physical Plant*

**Emil Zordilla**, *Director of Planning & Design*

### CONSULTANT TEAM

**Flad Architects**, *Architecture*

**WRT**, *Urban Design and Landscape Architecture*

**Mode Associates**, *Academic Planning*

**Affiliated Engineers, Inc.**, *Building Infrastructure*

**Nelson\Nygaard**, *Transportation Planning*

**KPFF**, *Site Infrastructure*

**Atelier 10**, *Sustainability*





# TABLE OF CONTENTS

## TABLE OF CONTENTS

### Chapter 1: Where We Are 28

Cal state Fullerton’s Character and Growth.....	29
The University’s Role in the Region.....	32
Town and Gown Relationship.....	33
Cal State Fullerton by the numbers- Fall 2019.....	34
Updating the Master Plan.....	36
What We Heard.....	44
Campus Now, Campus Next.....	48

### Chapter 2: What CSU Fullerton Needs 54

Academic Program / Entitlements.....	56
Campus Life Program.....	59
Sustainability and Infrastructure Strategies.....	65
Vision.....	68

### Chapter 3: How to Get There 78

Planning Principles.....	79
Master Plan 2039.....	79
Vision.....	79
Frameworks.....	79
Planning Principles.....	80
Design Guidelines/Frameworks.....	82

### CAMPUS BUILT FORM 95

Master Plan Build-out.....	96
Master Plan 2025 and Master Plan 2039.....	98
Districts.....	101
Built Form Program.....	109

### OPEN SPACE 121

Open Space Elements.....	123
--------------------------	-----

Green Loop.....	126
Axes.....	127
Perimeter.....	130
Plazas.....	131
Courtyards.....	134
Greens.....	135
Arboretum.....	136
Front Porches.....	138
Art and Identity.....	139

### MOBILITY 141

General Circulation.....	142
External Circulation.....	144
Transit Connectivity.....	148
Mobility Hubs.....	150
Transportation Demand Management.....	154

### INFRASTRUCTURE 159

Civil Infrastructure.....	159
Utilities / Mechanical, Electrical, and Plumbing.....	174

### RESILIENCY 183

Strategies for a Resilient Campus.....	184
Utility Resilience.....	187
Sustainable Strategies.....	188

### IMPLEMENTATION 193

Implementation Assumptions.....	194
Implementation Principles.....	196
Implementation Challenges.....	197
Funding and Cost projections.....	197
Project Rollout.....	198
Implementation of Focus Areas.....	199



# LIST OF FIGURES + TABLES

## FIGURE LIST

<b>Figure 1</b>	Physical Master Plan 2039 (Illustrative) .....	17	<b>Figure 31</b>	Campus Design Guidelines Frameworks.....	83
<b>Figure 2</b>	Learning, Activation, and Connection .....	19	<b>Figure 32</b>	Green Loop .....	84
<b>Figure 3</b>	Circulation Framework, Built Form, and Activation in the Physical Master Plan .....	22	<b>Figure 33</b>	Green Loop Section: Built Form Context .....	85
<b>Figure 4</b>	Existing Campus 2020 (Perspective View).....	24	<b>Figure 34</b>	Green Loop Section: Arboretum Context .....	85
<b>Figure 5</b>	Phases of the Physical Master Plan.....	24	<b>Figure 35</b>	Axes.....	86
<b>Figure 6</b>	Master Plan 2039 (Perspective View).....	25	<b>Figure 36</b>	Primary Axes along Longer Side of Buildings .....	87
<b>Figure 7</b>	Regional Map .....	32	<b>Figure 37</b>	Secondary Axes along Shorter Side of Buildings.....	87
<b>Figure 8</b>	2016 LA 5-County Employment Growth Rate.....	32	<b>Figure 38</b>	Building Heights across Campus.....	88
<b>Figure 9</b>	Cal State Fullerton and Surroundings.....	33	<b>Figure 39</b>	Typical Academic Building Height and Massing.....	89
<b>Figure 10</b>	Cal State Fullerton Enrollment Statistics.....	34	<b>Figure 40</b>	Typical Residential Building Height and Massing .....	89
<b>Figure 11</b>	Cal State Fullerton Physical Master Plan Area.....	36	<b>Figure 41</b>	Ground Floor Activation and Building Footprints Framework.....	90
<b>Figure 12</b>	Existing Facility Conditions .....	37	<b>Figure 42</b>	Typical Academic Building Ground Plane Activation and Footprint.....	91
<b>Figure 13</b>	Low FAR and Poor Condition Buildings.....	38	<b>Figure 43</b>	Typical Residential Building Ground Plane Activation and Footprint .....	91
<b>Figure 14</b>	Buildings Proposed to be Demolished.....	39	<b>Figure 44</b>	Campus Circulation Framework .....	92
<b>Figure 15</b>	California State University System.....	40	<b>Figure 45</b>	Automobile and Bicycle Internal Street .....	93
<b>Figure 16</b>	Cal State Fullerton Enrollment Growth.....	40	<b>Figure 46</b>	Typical Internal Street- Delivery Vehicle/Larger Vehicle .....	93
<b>Figure 17</b>	Cal State Fullerton Enrollment by College (Actual) .....	41	<b>Figure 47</b>	Physical Master Plan Build-out.....	96
<b>Figure 18</b>	Cal State Fullerton Enrollment by Year (Actual) .....	41	<b>Figure 48</b>	Master Plan 2025 and Master Plan 2039 Proposed Projects .....	98
<b>Table 1</b>	Headcount Analysis 2010 - Master Plan .....	42	<b>Figure 49</b>	Districts across Campus .....	100
<b>Figure 19</b>	Campus Now.....	48	<b>Figure 50</b>	Events and Innovation District Diagram .....	102
<b>Figure 20</b>	Campus Next .....	49	<b>Figure 51</b>	Residential and Student Life District Diagram .....	104
<b>Figure 21</b>	Existing Campus Character Areas .....	50	<b>Figure 52</b>	Mobility Hub and Main Entrance District Diagram.....	106
<b>Figure 22</b>	Conceptual Campus Character Areas.....	51	<b>Figure 53</b>	Overall Land Use Plan.....	108
<b>Figure 23</b>	Space Needs 2039 .....	56	<b>Table 4</b>	Program Summary .....	109
<b>Figure 24</b>	Space Entitlement per FTES by Discipline .....	57	<b>Figure 54</b>	Student and Faculty Housing.....	110
<b>Figure 25</b>	Space Needs by Discipline .....	57	<b>Table 5</b>	Student Housing and Student Life Program .....	111
<b>Table 2</b>	Current Entitlements, ASF: Assignable Square Feet .....	58	<b>Table 6</b>	Faculty Housing Program.....	111
<b>Table 3</b>	Master Plan Entitlements, ASF: Assignable Square Feet .....	58	<b>Figure 55</b>	Academic and Student Life.....	112
<b>Figure 26</b>	Elements of Physical Master Plan Vision.....	68	<b>Table 7</b>	Academic and Student Life Program .....	113
<b>Figure 27</b>	Connectivity Concept for the Physical Master Plan .....	72	<b>Table 8</b>	Event Center Program.....	114
<b>Figure 28</b>	Activation Concept for the Physical Master Plan .....	73	<b>Figure 56</b>	Event Center.....	114
<b>Figure 29</b>	Academic Concept for the Physical Master Plan .....	74	<b>Table 9</b>	Innovation Hub Program.....	115
<b>Figure 30</b>	Six Planning Principles for the Physical Master Plan .....	80	<b>Figure 57</b>	Innovation Hub.....	115
			<b>Figure 58</b>	Perspective View of Proposed Event Center.....	116



<b>Table 10</b>	Parking Structure Program .....	118
<b>Figure 59</b>	Parking Structures .....	118
<b>Table 11</b>	Arboretum Program.....	119
<b>Figure 60</b>	Arboretum Buildings .....	119
<b>Figure 61</b>	Open Space Illustrative Plan.....	122
<b>Figure 62</b>	Open Space Elements.....	123
<b>Figure 63</b>	Green Loop .....	126
<b>Figure 64</b>	Axes.....	127
<b>Figure 65</b>	Green Loop Perspective Illustration.....	128
<b>Figure 66</b>	Perimeter .....	130
<b>Figure 67</b>	Plazas .....	131
<b>Figure 68</b>	Bow-tie Plaza Perspective Illustration.....	133
<b>Figure 69</b>	Courtyards .....	134
<b>Figure 70</b>	Greens .....	135
<b>Figure 71</b>	Arboretum .....	136
<b>Figure 72</b>	Front Porches .....	138
<b>Figure 73</b>	Art and Identity .....	139
<b>Figure 74</b>	General Circulation.....	143
<b>Figure 75</b>	External Circulation.....	145
<b>Figure 76</b>	Nutwood Bridge Rendering.....	146
<b>Figure 77</b>	At-grade Street Enhancements .....	147
<b>Figure 78</b>	Typical Internal Street- Auto.....	148
<b>Figure 79</b>	Mobility Hub.....	150
<b>Figure 80</b>	Mobility Hub Perspective.....	152
<b>Figure 81</b>	Typical Internal Street- Auto.....	154
<b>Table 12</b>	Parking Supply .....	155
<b>Table 13</b>	Parking Demand <sup>4</sup> .....	155
<b>Figure 82</b>	Existing Sanitary Sewer.....	160
<b>Table 14</b>	Existing Sewer Flow from Facilities to be Replaced .....	161
<b>Table 15</b>	Sewer Flow from Proposed Facilities .....	162
<b>Figure 83</b>	Grouped Sewer Analysis of Proposed Facilities.....	163
<b>Figure 84</b>	Existing Storm Drain .....	165
<b>Figure 85</b>	Centralized Low Impact Design Strategy (Capture and Reuse).....	166
<b>Figure 86</b>	Storm Drain Management Examples .....	167
<b>Figure 87</b>	Localized Low Impact Design Strategy.....	168
<b>Table 16</b>	Existing Flow from Public Water Mains .....	169
<b>Figure 88</b>	Existing Water .....	170
<b>Table 17</b>	Proposed Building Fire Flow Requirements .....	171

<b>Table 18</b>	Fire Flow Analysis Results.....	171
<b>Figure 89</b>	Fire Flow Analysis Clusters.....	172
<b>Figure 90</b>	Fire Water Loop .....	173
<b>Figure 91</b>	Existing Chilled Water and Heating Hot Water System .....	175
<b>Table 19</b>	Proposed Cooling Load .....	176
<b>Table 20</b>	Proposed Heating Load .....	176
<b>Figure 92</b>	Existing Electrical System.....	178
<b>Table 21</b>	New Program Projected Electrical Demand in KW.....	179
<b>Table 22</b>	Future Natural Gas Loads .....	180
<b>Figure 93</b>	Existing Natural Gas System .....	181
<b>Table 23</b>	Projected FTE Growth and Required Academic GSF.....	193
<b>Figure 94</b>	Campus Today.....	193
<b>Figure 95</b>	Campus 2039.....	193
<b>Figure 96</b>	Opportunity Sites, Existing and Future .....	197
<b>Figure 97</b>	Cumulative Funding Proportions for Master Plan 2039.....	199
<b>Figure 98</b>	Proposed Implementation Focus Areas.....	199
<b>Figure 99</b>	Implementation Focus Area Summary.....	200
<b>Figure 100</b>	Massing Model: Focus Area A .....	202
<b>Figure 101</b>	Funding Proportion: Focus Area A.....	203
<b>Table 24</b>	Area and Cost Estimation: Focus A.....	203
<b>Figure 102</b>	Plan: Focus Area A.....	203
<b>Figure 103</b>	Massing Model: Focus Area B .....	204
<b>Figure 104</b>	Funding Proportion: Focus Area B.....	205
<b>Table 25</b>	Area and Cost Estimation: Focus B.....	205
<b>Figure 105</b>	Plan: Focus Area B .....	205
<b>Figure 106</b>	Massing Model: Focus Area C.....	206
<b>Figure 107</b>	Funding Proportion: Focus Area C.....	207
<b>Table 26</b>	Area and Cost Estimation: Focus C.....	207
<b>Figure 108</b>	Plan: Focus Area C.....	207
<b>Figure 109</b>	Massing Model: Focus Area D.....	208
<b>Figure 110</b>	Funding Proportion: Focus Area D.....	209
<b>Table 27</b>	Area and Cost Estimation: Focus D.....	209
<b>Figure 111</b>	Plan: Focus Area D.....	209
<b>Figure 112</b>	Massing Model: Focus Area E .....	210
<b>Figure 113</b>	Funding Proportion: Focus Area E.....	211
<b>Table 28</b>	Area and Cost Estimation: Focus E.....	211
<b>Figure 114</b>	Plan: Focus Area E .....	211



## EXECUTIVE SUMMARY

California State University, Fullerton thrives in the heart of Orange County, serving students who are mostly based in its catchment area but also serving students from well beyond those borders. The student population is diverse in its demographics and interests and the University continues to find ways to meet the divergent needs that are asked of it. It is serving the mission of the Strategic Plan and the purpose of the CSU System at large and doing so in ways that distinguish it from other campuses according to the needs of its community and the remarkable physical backdrop of a beautiful campus setting.

However, the future needs of the university will require substantial changes for it to continue to thrive.

Since Cal State Fullerton's inception over 50 years ago, the learning styles of each generation have continued to shift as have the areas of study in both breadth and depth. The campus and many of its buildings are no longer robust in their abilities to meet the needs of its students and faculty. Interest on the part of the University's business and industry partners in collaboration continues to grow, along with expectations; meanwhile, the neighborhoods that surround the University feel the pressures of that growth as well as the opportunities to benefit from its presence.

### PHYSICAL MASTER PLAN GOALS

Within this context of diversification and growth, the University holds its core commitment to student success at the center. Indeed, that commitment underlies the goals for the Physical Master Plan:

- Serve the future of society by providing a robust and relevant education,
- Improve graduation rates,
- Support problem-based learning,
- Promote research as learning and basic research as vital components of this knowledge-based community,
- Promote cross discipline collaboration,
- Increase quality student/professional interaction,
- Build community connection and support.

To meet these goals, the Physical Master Plan presents strategies that balance programmatic and behavioral needs with the physical identity and plan for the campus and its built environment. It provides a road map for these changes so that future leadership can build toward fulfilling its potential and sustain a healthy institution in a manner that follows a logic, sets clear priorities, and is achievable. It provides the common ground on which future conversations about disruptions to pedagogy, culture and place may occur while never losing sight of the long-term outcomes desired.

### Campus Strategic Plan Mission

California State University, Fullerton enriches the lives of students and inspires them to thrive in a global environment. We cultivate lifelong habits of scholarly inquiry, critical and creative thinking, dynamic inclusivity, and social responsibility. Rooted in the strength of our diversity and immersive experiences, we embolden Titans to become intellectual, community, and economic leaders who shape the future.

*This Physical Master Plan addresses the future of Cal State Fullerton through the year 2039. It covers changes projected in enrollment, pedagogy, academic and support uses, transportation; utility infrastructure, energy and transportation, all in support of the CSU system's Graduation Initiative 2025 and Cal State Fullerton's Academic Master Plan.*




- Proposed Buildings 
- Existing Buildings 
- Project Boundary 

Figure 1. Physical Master Plan 2039 (Illustrative)







Rendering of the Green Loop in front of the Student Union

Figure 2. Learning, Activation, and Connection



## VISION

The Physical Master Plan offers a special opportunity to align place and purpose and to address the most critical drivers in a way that serves a broader vision. Based on engagement with students, faculty, and staff, five areas of focus emerged.

### Identity

Cal State Fullerton seeks to establish an identity as a place of inclusion and create a sense of belonging and pride. The Physical Master Plan will support identity creation by:

- Creating a sense of place tied to the academic activities and amenities that compose each part of campus,
- Improving connections to neighborhoods and transportation systems at the edges of campus,
- Improving and activating the connections between indoor and outdoor activities at the ground plane,
- Improving wayfinding,
- Moving from being commuter centric to student experience focused,
- Finding ways to improve visibility of student work and student life, and
- Connecting all parts of campus together.

### Values

The celebration of diversity and a commitment to sustainability, social equity, health and wellness should be reflected on campus.

This may be achieved by:

- Supporting student voices and ideas expressed within diverse settings for demonstration and display,
- Creating club spaces and learning spaces specific to the needs of different groups,
- Improving the condition of buildings and landscapes so that they reflect a sense of value and pride.

### Learning

The campus supports academic programs, instills the desire to be present and to learn, and provides the means to teach and learn in the most effective and contemporary ways. This includes removing outmoded and ineffective space, allowing for greater use of informal learning spaces, and having safe and comfortable spaces to think and decompress – for students and faculty alike.

Strategies include:

- Creating a student-focused non-departmental building, or an “Innovation Hub,” to support multi-disciplinary collaborations and innovation,
- Creating appealing in-between spaces at the thresholds to classrooms and building entrances.

### Activation

Cal State Fullerton is an active campus environment during and after class hours, in the evening and on weekends, and is accessible to its diverse population of students and the community at large.

Campus is a place where things are happening and can happen, and where people want to be. It should feature small, more intimate outdoor spaces that take advantage of California’s climate. Students, faculty and staff use space outside for gathering, studying, eating, displays, fairs, celebrations, art and artifacts.

The feeling of vitality on campus is achieved through:

- Establishing a “heart of campus,” with quality social places,
- Increasing utilization of campus land,
- Creating 24/7 housing and lifestyle amenities on campus,
- Creating a safe campus for all.

### Connection

At Cal State Fullerton, all parts of campus feel composed and unified. Traversing campus is clear, safe and inviting. The physical environment manifests the University’s academic organization and reinforces connections within academic “neighborhoods” as well as between them. The campus is also connected to the broader community.

Connection is supported by:

- Wayfinding within campus and at the intersections to the community,
- Diverse modes of transport that help the campus community spend more time teaching and learning,
- Establishing a better connection to downtown Fullerton and regional transportation systems helping commuters to reduce auto dependency.



## DRIVERS OF THE PHYSICAL MASTER PLAN



### Right Sizing for Modest Growth

The campus is undersized in its “entitled” academic space. Compounding this condition, the campus is very under-served by supporting, non-academic spaces. This combination manifests itself through continued use of limited and often outmoded learning spaces, resulting in students leaving campus before or after scheduled classroom or lab hours. The Master Plan corrects for undersizing and also grows to meet overall future needs based on modest growth of 1 percent per year in full-time equivalent student (FTES) body.



### Building a 24-hour Community

An increase in housing will help establish a 24-hour community on campus. In turn, this will foster peer-to-peer learning, a strategy that has proven to increase graduation rates and quality of life. This moves the University from the low end of student housing available on campus to more of a middle position in the CSU System. The change is emblematic of the shift from being a commuter-based campus to being a residential campus. To support this housing, diverse informal learning opportunities will be increased across campus, encouraging more peer-to-peer learning in the presence of faculty and partners that can aid in the process.



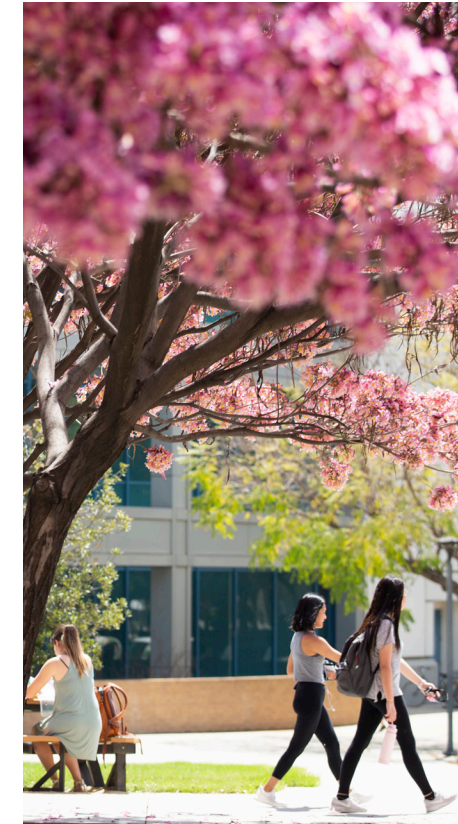
### Strengthening the Academic Core

Knowing that several structures have outlived their usefulness, the Physical Master Plan lays out a more densely populated core including replacement buildings and building additions. The Plan leaves the assignment of building program to future decision makers. As the lines between disciplines in higher education are increasingly blurred, a more dense core campus will flexibly serve diverse and vital academic activity and support broad academic interests.



### Building a Community and Culture of Lifelong Learning

The plan is designed to draw the community onto campus and enrich the student experience including the use of the proposed Event Center on the eastern edge of campus, the re-dedication of scholarly use of the Arboretum and the proposed Innovation Hub at the core of campus.



### Repositioning the Role of Open Space

Decades of development has taken its toll on the character and quality of open space, the public walkways, and campus spaces that are integral to the daily campus experience. The Physical Master Plan provides a more intentional array of campus spaces and more clarity in the scale and role of primary pedestrian pathways, including a reconstitution of the historic campus loop path.



### Acting on Values of Wellness and Sustainable Living

The Physical Master Plan promotes an increase in the use of public and shared transportation modes by establishing three multi-modal transportation hubs and suggesting limits on the use of single occupancy vehicles. The establishment of student housing along with social spaces, exercise amenities, and areas of respite reinforce the University's commitment to student experience and quality of life.



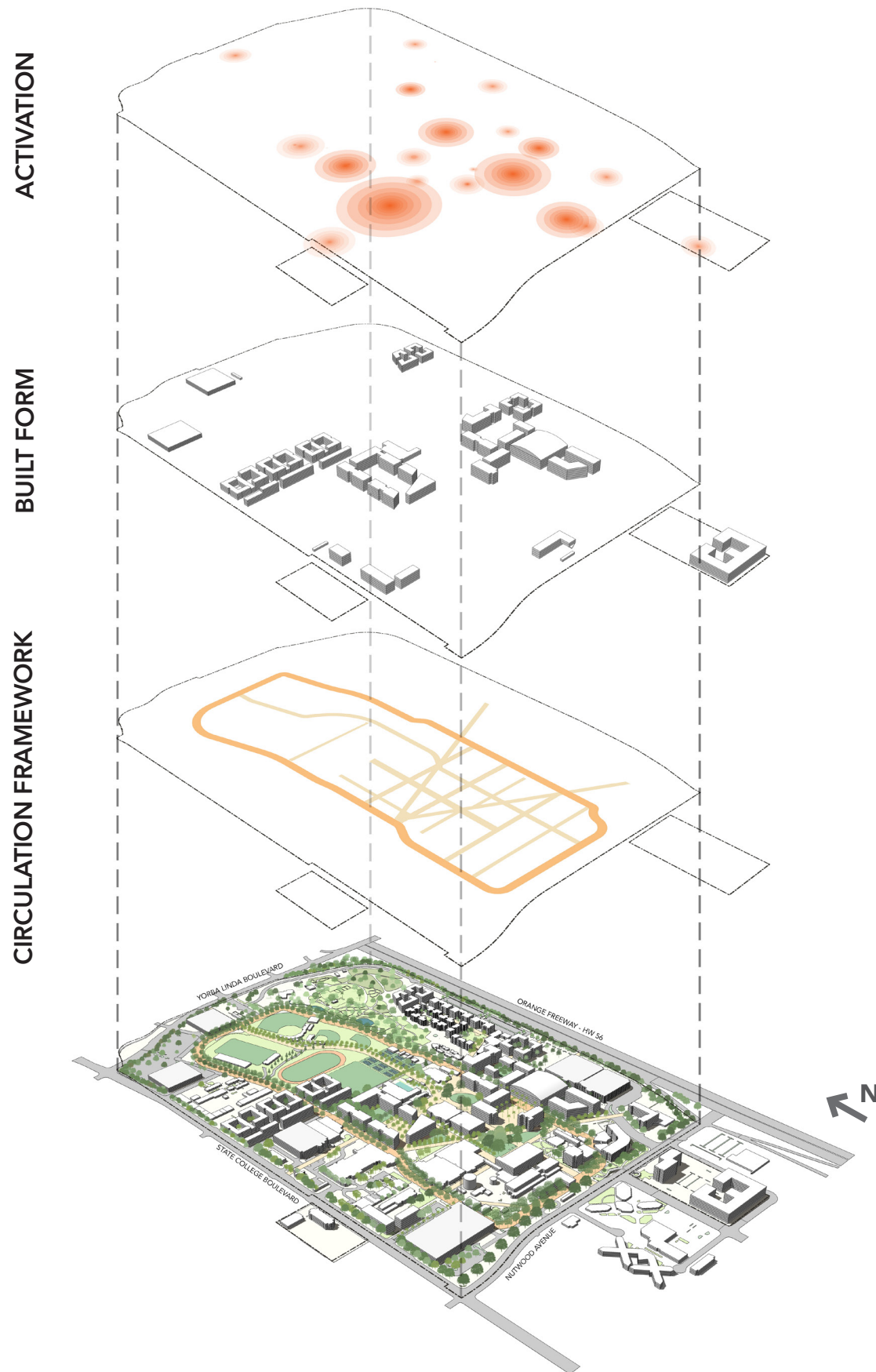


Figure 3. Circulation Framework, Built Form, and Activation in the Physical Master Plan

## PLANNING PRINCIPLES AND FRAMEWORK

The Physical Master Plan supports a series of outcomes, suggested by the vision and drivers:

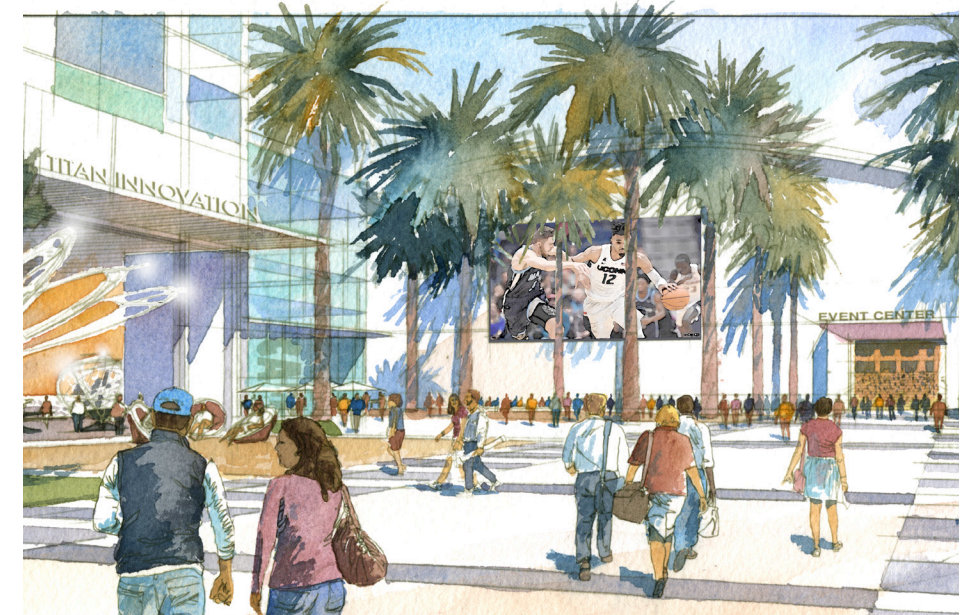
- Transitioning from a commuter to a residential campus,
- Supporting academic needs,
- Making way for transformation by redeveloping obsolete buildings and sites,
- Leaving space for future growth,
- Sharing resources across the campus, and
- Establishing campus framework and open space as part of the learning environment.

The design framework begins with establishing a circulation system composed of a Green Loop and cross campus axes. This system clarifies and enhances the existing campus pattern, while opening up strong new lines of sight and access.

Next, the Physical Master Plan establishes a new pattern of building height and density. New buildings create a new predominant scale of six-story academic buildings in the campus core, while preserving substantial open spaces.

And third, the Plan emphasizes an active, inside/outside connection between the ground floors of buildings and the open spaces they face.

The Physical Master Plan defines a series of districts defined by their distinct program (housing, academic and student life, event center, innovation center), and a typology of campus open spaces, including courtyards, front porches and plazas.



Rendering of the Innovation Hub and Event Center

## CONCLUSION

What benefits can students, faculty, staff and members of the Fullerton community expect to see with the realization of the Physical Master Plan?

- **Increased learning:** Students will find that they are conveniently served by clusters of academic, supporting amenity and informal learning spaces that enable them to use their time efficiently and stay on campus in the presence of their fellow students and faculty.
- **Strategic implementation with flexibility at core:** Administrators have a pathway to incremental replacement of buildings that should serve their desires to connect problem-based teaching/learning pedagogy to research and informal learning experiences that will mark an overall increase in the quality of their approach.
- **Increased focus on values and community:** Ease of movement across campus, greater use of

campus for well-being, increased opportunities for hosting cultural events and the establishment of spaces for the display of research, development and innovation across all fields are expected to flow from the Physical Master Plan. This means more student engagement and a more vibrant campus open to greater community use and expanded support from business and industry collaborators.

- **Identity and culture shifting with an eye to the future:** By its thoughtful planning, the University takes a strong new step in acting on values that benefit future learners and supports its position as a leader in the academe. In doing so, it benefits from seeking change that will be recognized as competitive, vital and a point of strength and pride in Southern California.



Figure 4. Existing Campus 2020 (Perspective View)

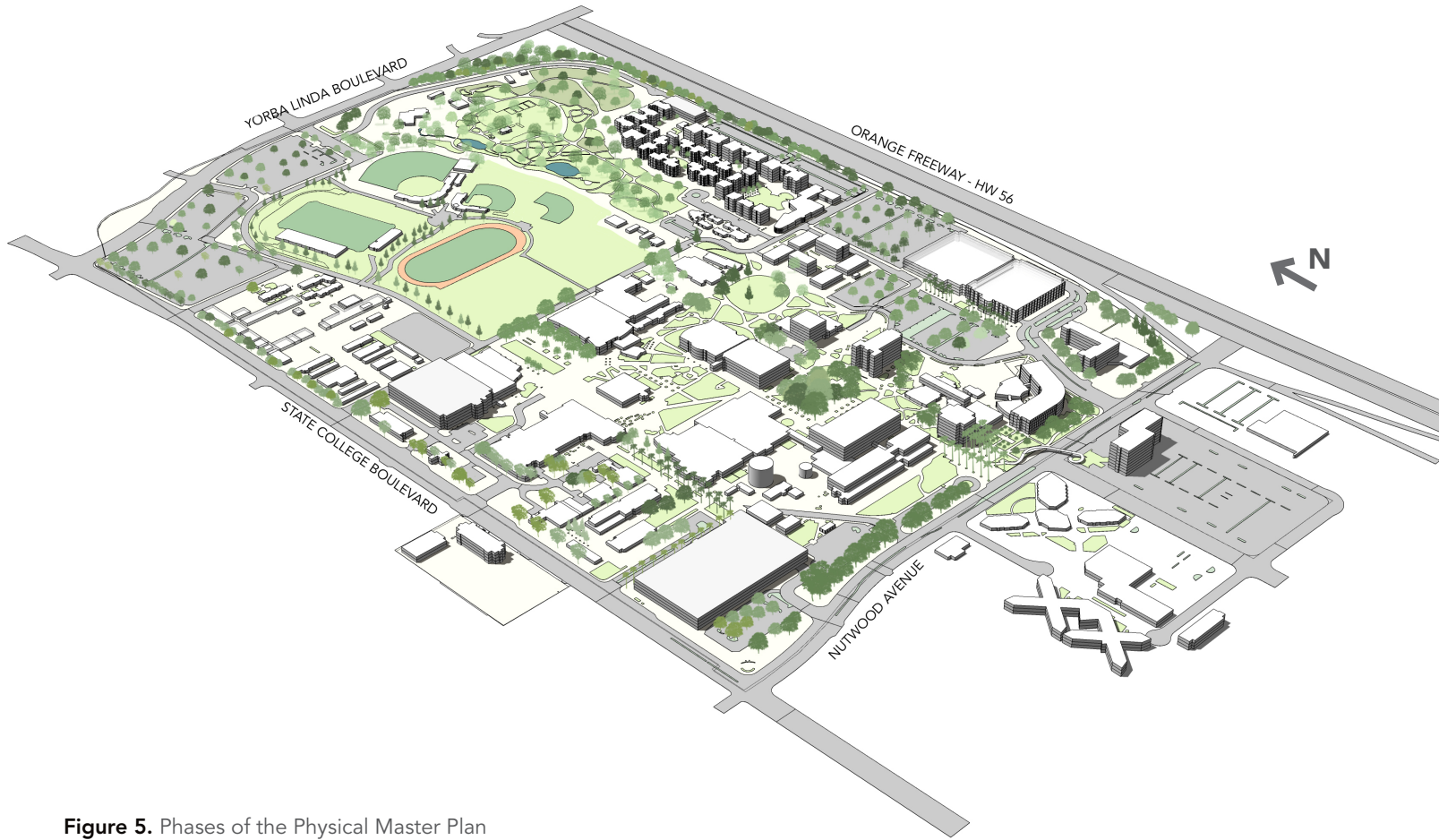
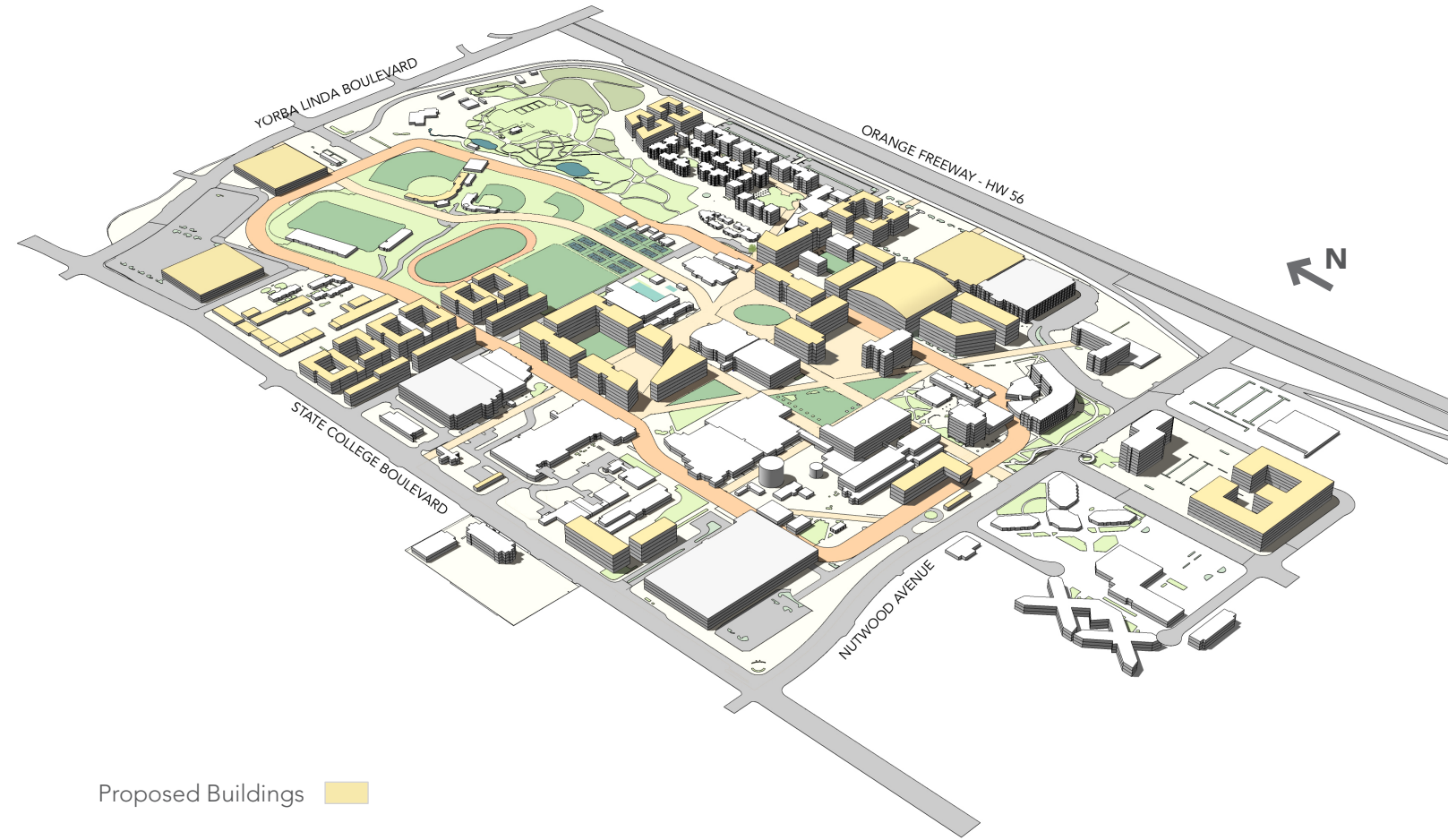


Figure 6. Master Plan 2039 (Perspective View)



Proposed Buildings

Figure 5. Phases of the Physical Master Plan



Phase A: Immediate Projects



Phase B: 5 Year Capital Plan



Phase C: Residency



Phase D: Community



Phase E: Pedagogy



Near Term    Long Term  
Phase Summary



CALIFORNIA STATE UNIVERSITY  
FULLERTON





## Chapter

# 1

## WHERE WE ARE

- CSU Fullerton's Character and Growth
- The University's Role in the Region
- Town-Gown Relationship
- Updating the Master Plan
- What We Heard

## CAL STATE FULLERTON'S CHARACTER AND GROWTH

California State University, Fullerton is a leading campus of the California State University System, serving as an intellectual and cultural center for Southern California and driver of workforce and economic development. The University is an emerging national model for supporting student success through innovative, high-impact educational and co-curricular experiences, including faculty-student collaborative research.

Rising from orange groves in 1959, Cal State Fullerton has grown from its modest start to a comprehensive and dynamic university in a short time. In its first decade, the University built seven permanent facilities and grew to 9,500 full-time equivalent (FTE) enrollment. Original buildings included McCarthy Hall, Performing Arts, Kinesiology and Health Sciences, Pollak Library, Bookstore, Humanities and Social Sciences, and Visual Arts. These supported the core academic needs of a young, growing campus in its first decade and laid a solid foundation for further expansion.

In the 1970s, enrollment grew by 36 percent and five additional significant permanent facilities were completed, including Langsdorf Hall, the College of Engineering, Student Health Center, the Student Union, and a major expansion of the Visual Arts. The 27-acre Fullerton Arboretum was established in 1979, through a joint powers agreement with the City of Fullerton. The Arboretum has become a significant attraction in Fullerton, hosting tens of thousands of visitors annually, and year-round programs and events.

The Fullerton campus currently houses eight colleges: Arts, Business and Economics, Communications, Engineering and Computer Science, Education, Health and Human Development, Humanities and Social Sciences, and Natural Sciences and Mathematics. The 2,151 full- and part-time faculty teach 55 undergraduate and 54 graduate programs including a doctorate in Education and doctor of nursing practice. Cal State Fullerton's 254,000 graduates are a vital asset to the Orange County community, to the region, and to the State of California. Cal State Fullerton also operates two off-campus centers in Garden Grove and Irvine Center, which are not part of this Physical Master Plan.

As a result of rapid expansion since 2002, the Fullerton campus currently has 109 permanent buildings totaling about 5.6 million gross square feet (GSF). The campus has made the transition from a young, suburban campus to a mature, urban one. In 2003, the master plan enrollment capacity of the Fullerton campus was increased from 20,000 to 25,000 full-time-equivalent (FTE). As it reaches its 25,000 FTE capacity, the campus now considers increasing its master plan capacity to **32,000 FTE**, including the main campus annualized lab and lecture enrollment.

Cal State Fullerton's capital outlay program continues to implement its 2003 Master Development Plan. Major capital projects that have completed construction since 2010 include the University Police Facility, Children's Center, expansion of the central utilities plant, Eastside Parking Structure, and Student Housing and Dining Phases 3 and 4. The Auxiliary

---

We are a comprehensive, regional university with a global outlook and a local focus.

---

Services Corporation acquired and remodeled two buildings for the Irvine Center branch campus.

The expansion of the Titan Student Union was completed in spring 2016. Elements of the campus utilities infrastructure are being upgraded. The Pollak Library is being remodeled in accordance with the system-wide initiative called Library of the Future. Large areas of the campus landscape have been converted with grant funds to low-water or no-water consumption planting and ground cover. The



campus photo-voltaic system is being expanded from one megawatt to five megawatts, increasing the system's electric-generating capacity in support of sustainability goals. Remodeling and seismic retrofit were recently completed at Titan Hall, a building adjacent to the campus acquired in 2012 for University Extended Education and other uses.

## CALIFORNIA STATE UNIVERSITY, FULLERTON MISSION STATEMENT

"Learning is preeminent at California State University, Fullerton. We aspire to combine the best qualities of teaching and research universities where actively engaged students, faculty and staff work in close collaboration to expand knowledge.

Our affordable undergraduate and graduate programs provide students the best of current practice, theory, and research, and integrate professional studies with preparation in the arts and sciences. Through experiences in and out of the

classroom, students develop the habit of intellectual inquiry, prepare for challenging professions, strengthen relationships to their communities and contribute productively to society.

We are a comprehensive, regional university with a global outlook, located in Orange County, a technologically rich and culturally vibrant area of metropolitan Los Angeles. Our expertise and diversity serve as a distinctive resource and catalyst for partnerships with public and private organizations. We strive to be a center of activity essential to the intellectual, cultural and economic development of our region."

## OVERARCHING GOALS OF THE UNIVERSITY

- 1 ENSURE THE PREEMINENCE OF LEARNING
- 2 PROVIDE HIGH-QUALITY PROGRAMS THAT MEET THE EVOLVING NEEDS OF OUR STUDENTS, COMMUNITY AND REGION
- 3 ENHANCE SCHOLARLY AND CREATIVE ACTIVITY
- 4 MAKE COLLABORATION INTEGRAL TO OUR ACTIVITIES
- 5 CREATE AN ENVIRONMENT WHERE ALL STUDENTS HAVE THE OPPORTUNITY TO SUCCEED
- 6 INCREASE EXTERNAL SUPPORT FOR UNIVERSITY PROGRAMS AND PRIORITIES
- 7 EXPAND CONNECTIONS AND PARTNERSHIPS WITH OUR REGION
- 8 STRENGTHEN INSTITUTIONAL EFFECTIVENESS, COLLEGIATE GOVERNANCE AND OUR SENSE OF COMMUNITY





## THE UNIVERSITY'S ROLE IN THE REGION

Cal State Fullerton sits within the Los Angeles region, which includes both Los Angeles and Orange Counties. Other California State University campuses in the region include Cal State Northridge, Dominguez Hills, Los Angeles and Long Beach. As a group these institutions have a direct economic impact of \$2.6 billion.

The Los Angeles region is home to one in four Californians, and if ranked as a national economy would represent the 17th largest in the world, just behind Spain and Australia. The State of California ranks fifth. All of which is to say, Cal State Fullerton has a prime location in a powerfully robust region. Continued economic growth is expected in the larger LA Basin five-county region (the primary source of Cal State Fullerton applicants and destination region for graduates) in areas necessitating a secondary education, such as healthcare, creative services, government, and high tech.

Like many areas of California that have seen particularly robust economic growth over a long period, a housing shortage is impacting the potential economic performance of the region. Cal State Fullerton has struggled to

recruit faculty and staff for this reason (amongst others) which is further impacting the campus' ability to grow to meet student demand.

Figure 7. 2016 LA 5-County Employment Growth Rate

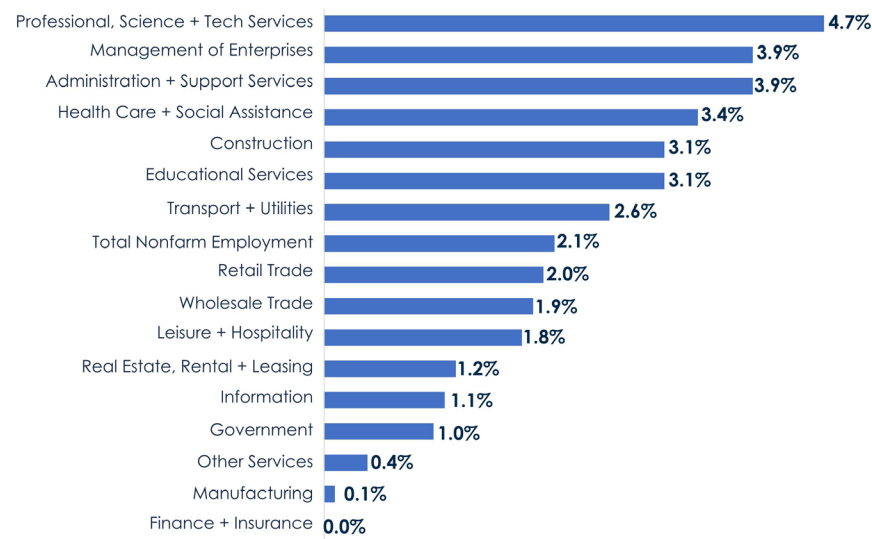


Figure 8. Regional Map



## TOWN AND GOWN RELATIONSHIP

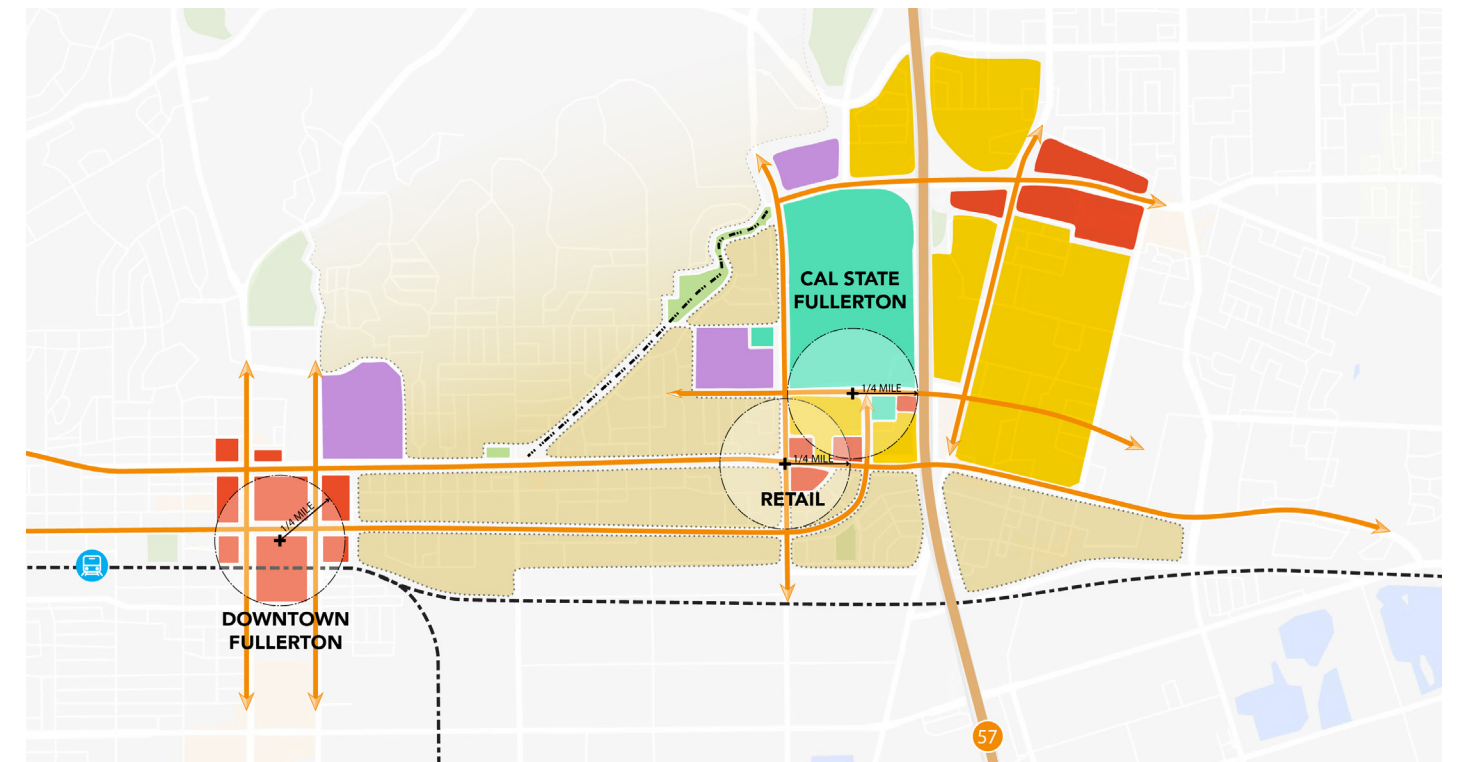
The city of Fullerton dates back to the 1880s and grew to become a thriving town surrounded by orange groves and connected to the region and beyond by rail. The town gained a foothold in Southern California's aerospace industry, and then grew rapidly during the post-World War II years as Orange County suburbanized. This growth helped earn Fullerton a campus of the California State University system, and since Cal State Fullerton's establishment in 1957, the identities of town and university have been linked.

Today, the University is Fullerton's largest employer and has a strong multiplier effect on the local economy. Cal State Fullerton supports a highly-educated workforce, while also providing (directly and indirectly) a diverse range of service jobs. The other side of this coin is that the University is a major commute

destination, bringing people from all over the region, which generates traffic and parking issues in Fullerton.

Cal State Fullerton and the City have both recognized an opportunity to create a vibrant "town/gown" relationship and look forward to creating a stronger connection between the University and Downtown Fullerton, helping both thrive together.

Figure 9. Cal State Fullerton and Surroundings

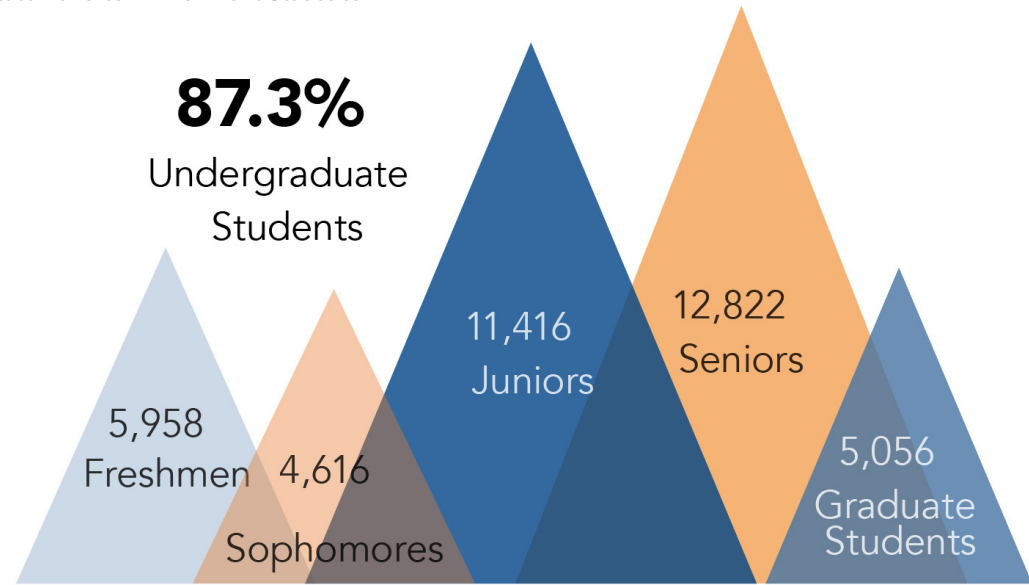




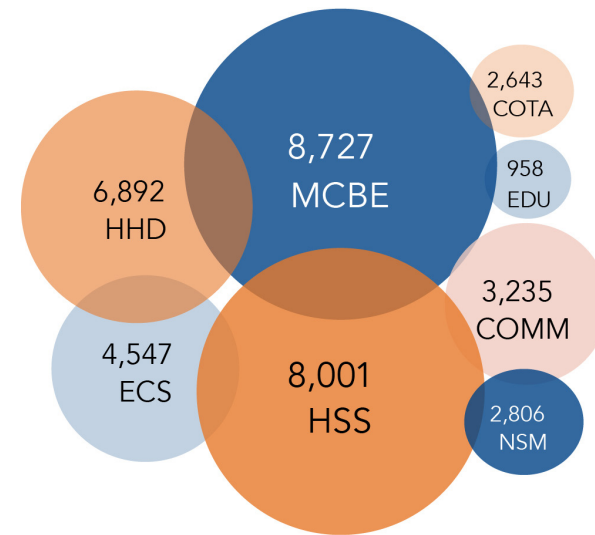
# CAL STATE FULLERTON BY THE NUMBERS- FALL 2019

Source: Cal State Fullerton, Division of Academic Affairs

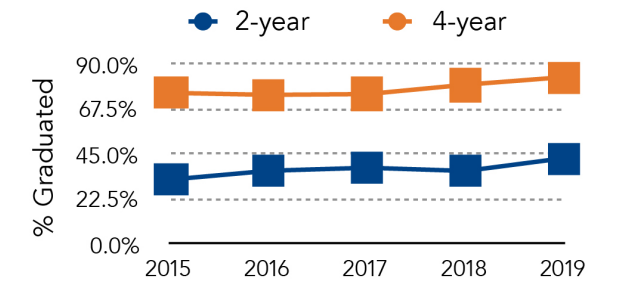
Figure 10. Cal State Fullerton Enrollment Statistics



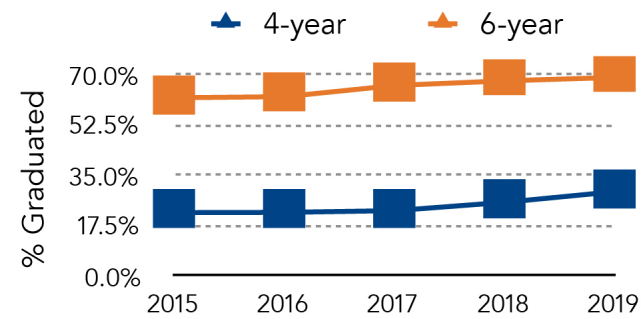
## One University, Many Schools



**42.7%** (estimated)  
2- year Graduation  
(Undergraduate Transfer Students)

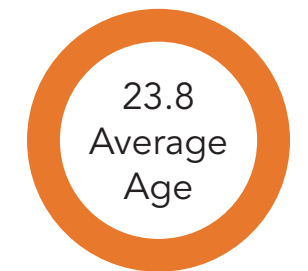
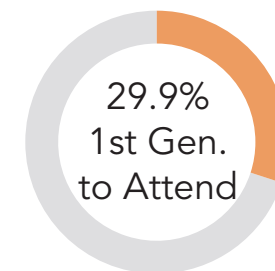
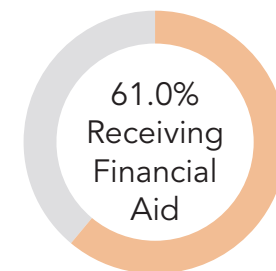
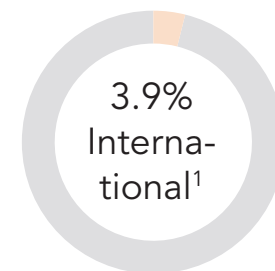
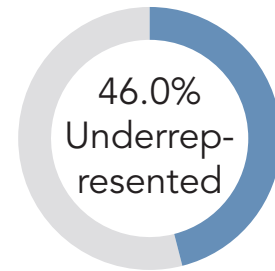
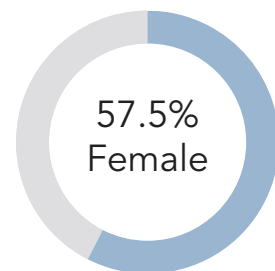
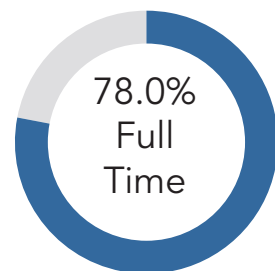
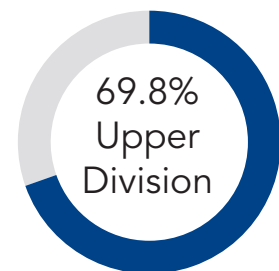
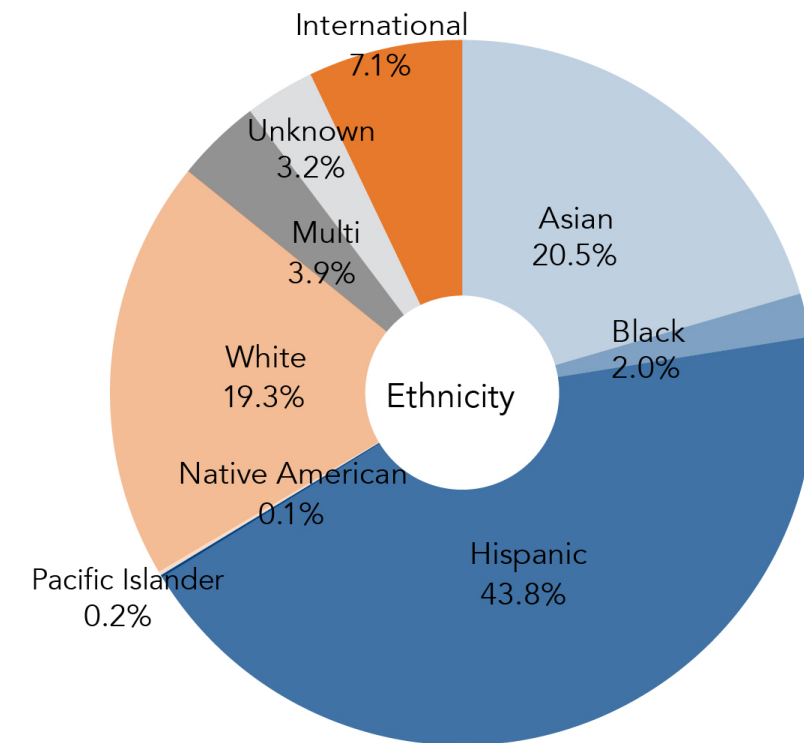


**29.2%** (estimated)  
4- year Graduation  
(First-time Full-time Freshmen)



**83,154**  
Total Number of Applications

**11,585**  
Total Number of Degrees in 2018-2019



<sup>1</sup>Underrepresented = Native American, Black, Hispanic & Pacific Islander

<sup>1</sup>Underrepresented = Native American, Black, Hispanic & Pacific Islander



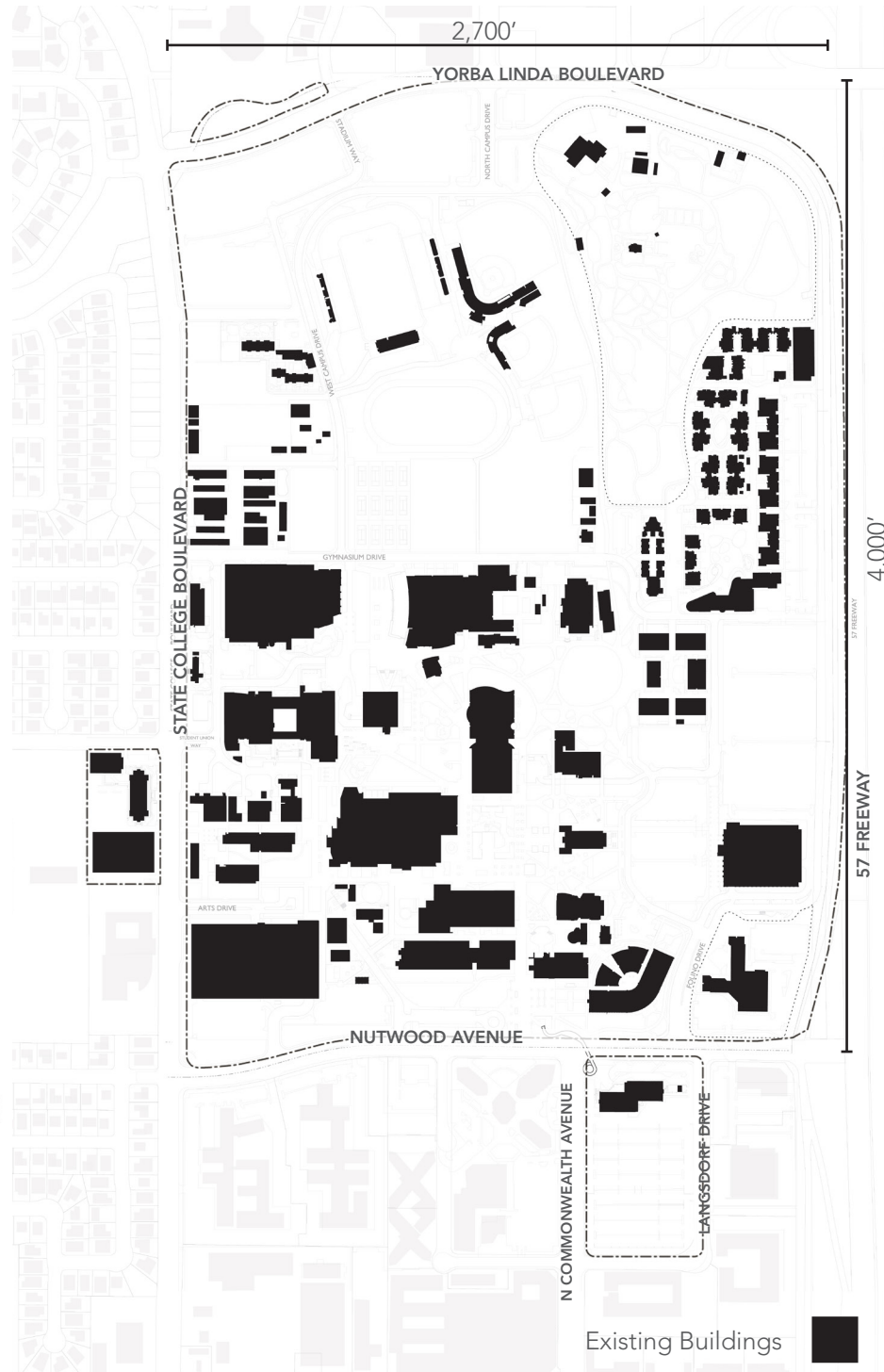
# UPDATING THE MASTER PLAN

## DEFINING THE CAMPUS

The Physical Master Plan addresses the main Cal State Fullerton campus, bounded to the south by Nutwood Avenue, to the west by State College Boulevard, to the north by Yorba Linda Boulevard and to the east by State Highway 57, which includes the Arboretum.

Additionally, the Physical Master Plan includes the College Park building on the south side of Nutwood Avenue bounded by North Commonwealth Avenue and Langsdorf Drive, and Titan Hall on the west side of State College Boulevard. The facilities, capacity and future development of the other campus locations, including Cal State Fullerton Irvine Center and the Grand Central Art Center in Santa Ana are not addressed by this campus master plan. The campus is 241 acres.

**Figure 11.** Cal State Fullerton Physical Master Plan Area



## EXISTING FACILITY CONDITIONS

The Physical Master Plan reviews the conditions of campus facilities and categorizes them based on the total cost of deferred maintenance, recurring cost for replacement and non-recurring needs addressing code and safety items. These costs are then expressed as a percentage against the total cost of facility replacement. Facilities with a low percentage (0%-20%) are considered good to excellent, fair and below average (30%-50%) require some level of renovation, poor (60%) require total renovation and those greater than 60 percent are recommended for replacement. Figure 12 represents the findings, based on the 2015 ISIS Facility Condition Assessment.

**Figure 12.** Existing Facility Conditions

Building Condition	FCNI Score	Color
Excellent	< 0.10	Green
Good	< 0.20	Blue
Fair	< 0.30	Yellow
Below Average	< 0.50	Purple
Poor	< 0.60	Orange
CFRI (Complete Facility Replacement Indicated)	≤ 0.60	Red

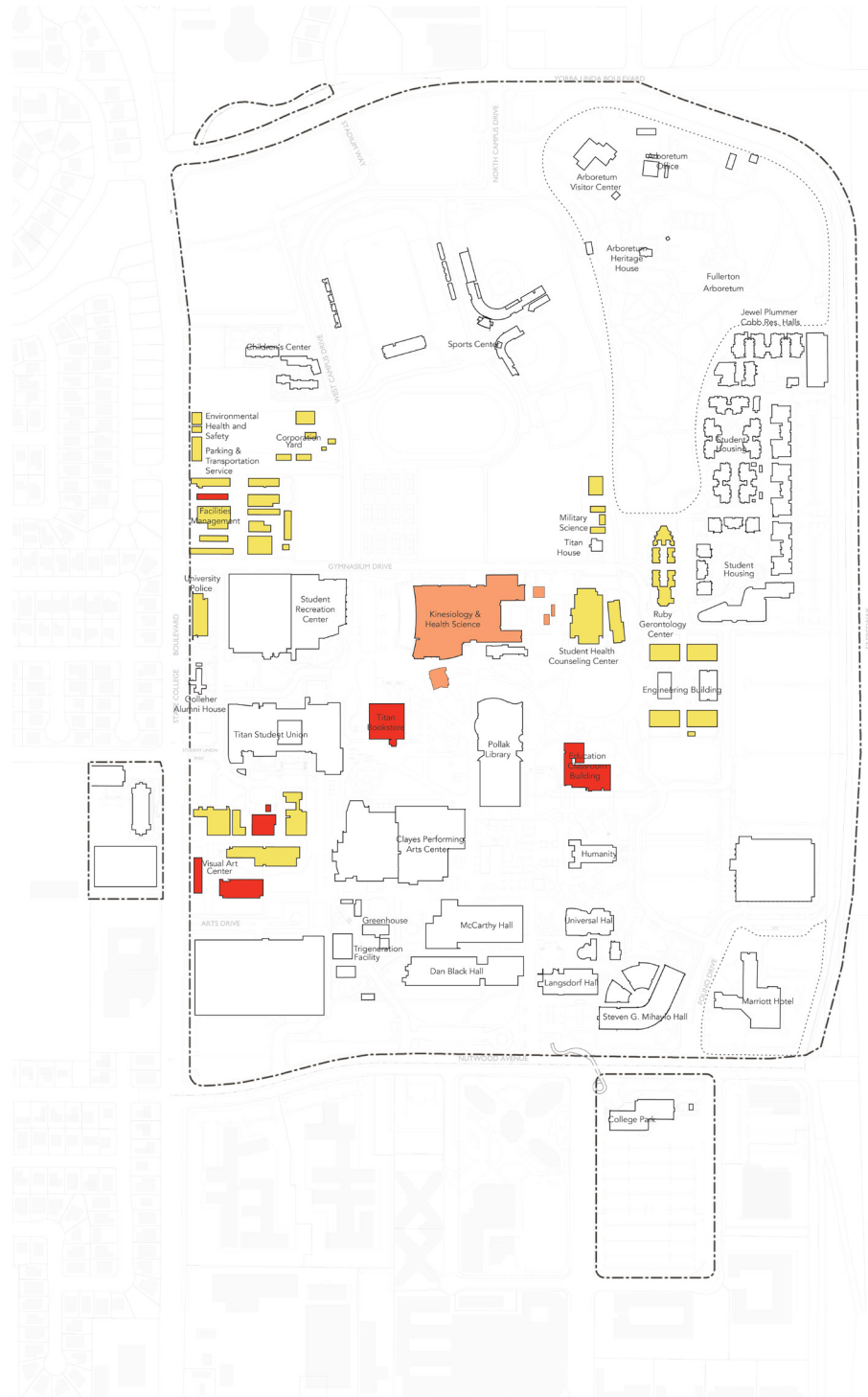




## BUILDING UTILIZATION ANALYSIS

With the main campus being landlocked with limited ability to grow efficient use of land becomes a critical consideration. The Physical Master Plan identifies low-rise buildings, defined in this study as being up to two levels, in an effort to illustrate where additional capacity could be achieved if a taller building with greater land development density was adopted.

**Figure 13.** Low FAR and Poor Condition Buildings

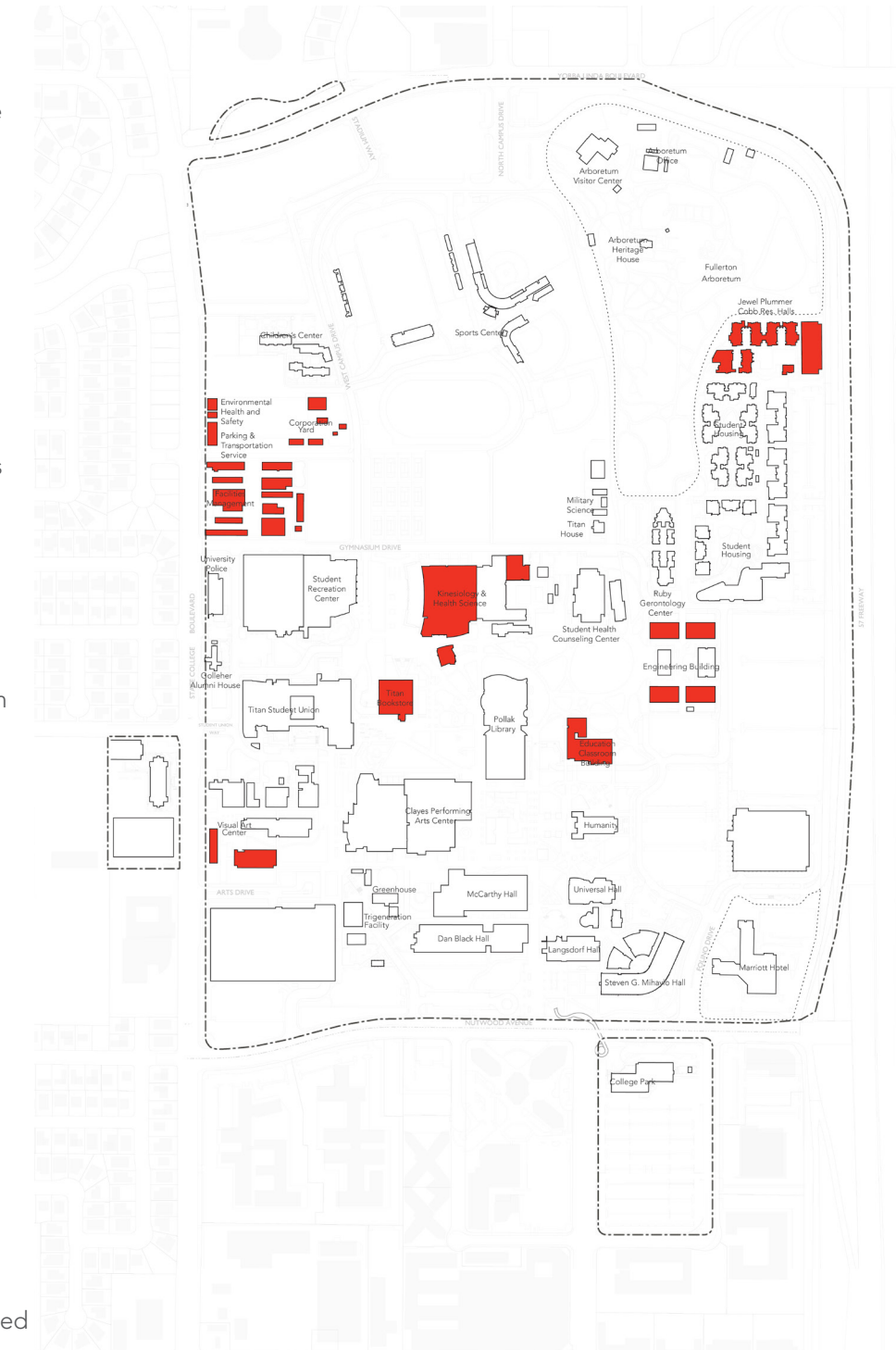


- Low-rise buildings (1-2) Stories
- Proposed Program Replacement
- Complete Facility Replacement Indicated (Ranked below Poor)

## BUILDINGS TO BE POTENTIALLY REPLACED

Based on the analysis of the building condition and floor area ratio, the following buildings have been proposed for potential replacement. Programs in these buildings would be accommodated in new or renovated facilities identified in the Physical Master Plan.

**Figure 14.** Buildings Proposed to be Demolished



- Jewell Plummer Cobb Residential Hall- 600 bed housing and parking
- Titan Bookstore
- Education Classroom Building
- Single Level Engineering Buildings
- Visual Arts Buildings
- Anthropology Storage
- Goodwin Field Press Box
- Corporation Yard/ Facilities Management
- Parts of the Kinesiology and Health Science Building

Figure 14 outlines the locations of buildings identified for potential replacement.

- Potential Buildings to be Replaced



# ENROLLMENT

Cal State Fullerton currently enrolls approximately 25,000 full-time equivalent (FTE) students. Cal State Fullerton is ranked sixth in the nation in Bachelor's degrees awarded to minority students. Its Mihaylo College of Business and Economics is home to the state's largest nationally accredited undergraduate business program, and its drama, musical theater and dance programs are all nationally recognized.

Cal State Fullerton is an impacted campus for all disciplines / majors for first-time freshman. This impaction has resulted in more rigorous standards being applied to applicants. While students in the local area (Orange County, Walnut, Whittier, Chino Valley, Corona, Norco and Alvorad schools) are given first priority to gain admission, potential students must have a stronger Eligibility Index to be accepted. Given its location and the quality of its programs, Cal State Fullerton regularly has one of the largest applicant pools in the system. In Fall 2019, the campus accepted only 43 percent of applicants.

## Demand Analysis

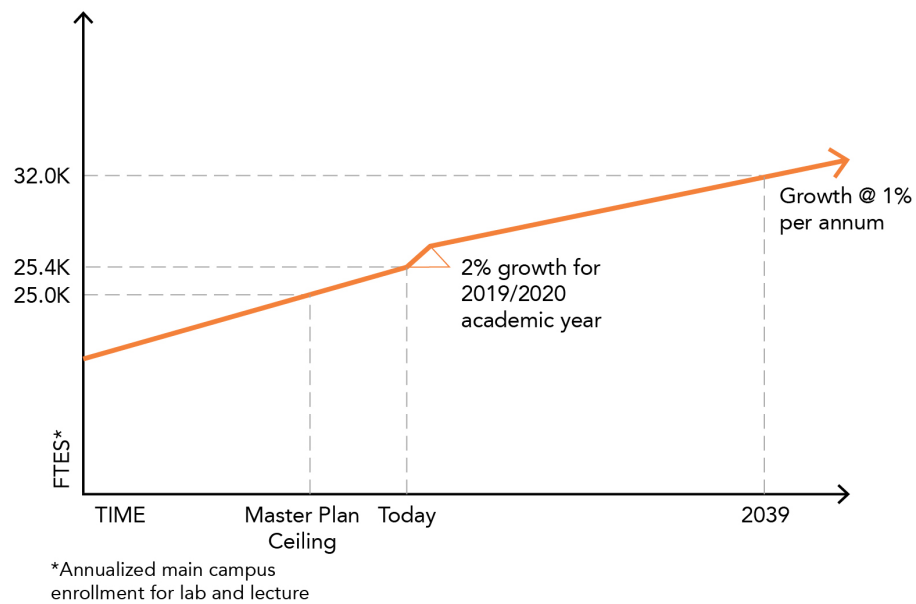
California public high school graduation rates have been relatively steady in recent years. The Department of Finance's demographic unit anticipates a small up-tick in graduation rates through 2023 with a decline the following year. The incremental statewide graduation rate growth, together with the likely increase of transfer applicants from the California Community College system due to The California Promise, is anticipated to result in further increases in student enrollment demand.

Figure 15. California State University System



Cal State Fullerton regularly has one of the largest applicant pools in the CSU system. In Fall 2019, the campus accepted only 43% of applicants.

Figure 16. Cal State Fullerton Enrollment Growth



## Enrollment Trends

In the last ten years campus enrollment has grown an average of 1.2 percent per year. Given the state's constrained enrollment funding (campuses are generally funded at a 1 percent growth rate year after year), pressure is high on the campus to manage enrollment. This is made more difficult by its impaction status and location in the region. In some years (2012) the campus has grown by 5 percent. In the last five years, the campus has generally grown by approximately 2 percent. This growth rate is seen as more rational, but the state must continue to guarantee funding for it to be considered fiscally sustainable.

Figure 17. Cal State Fullerton Enrollment by Year (Actual)

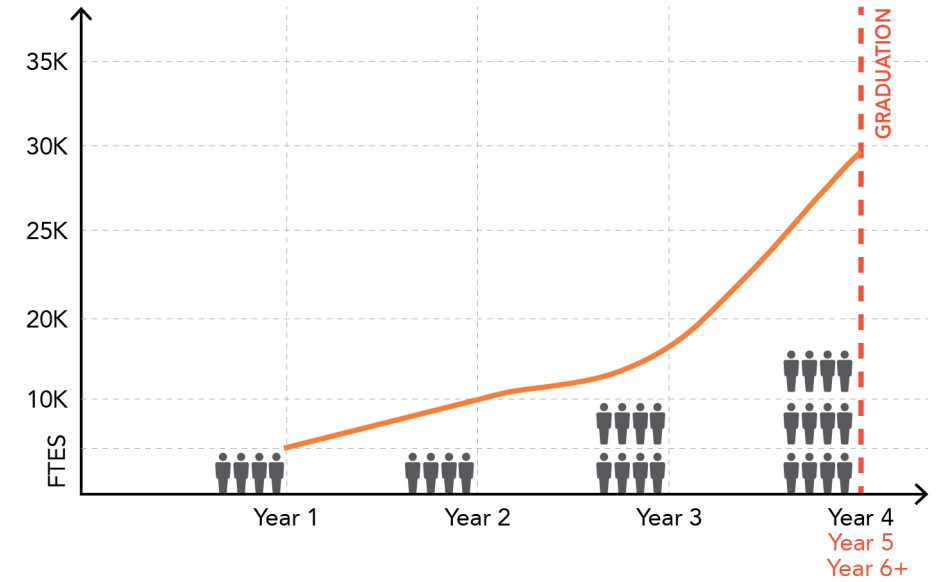
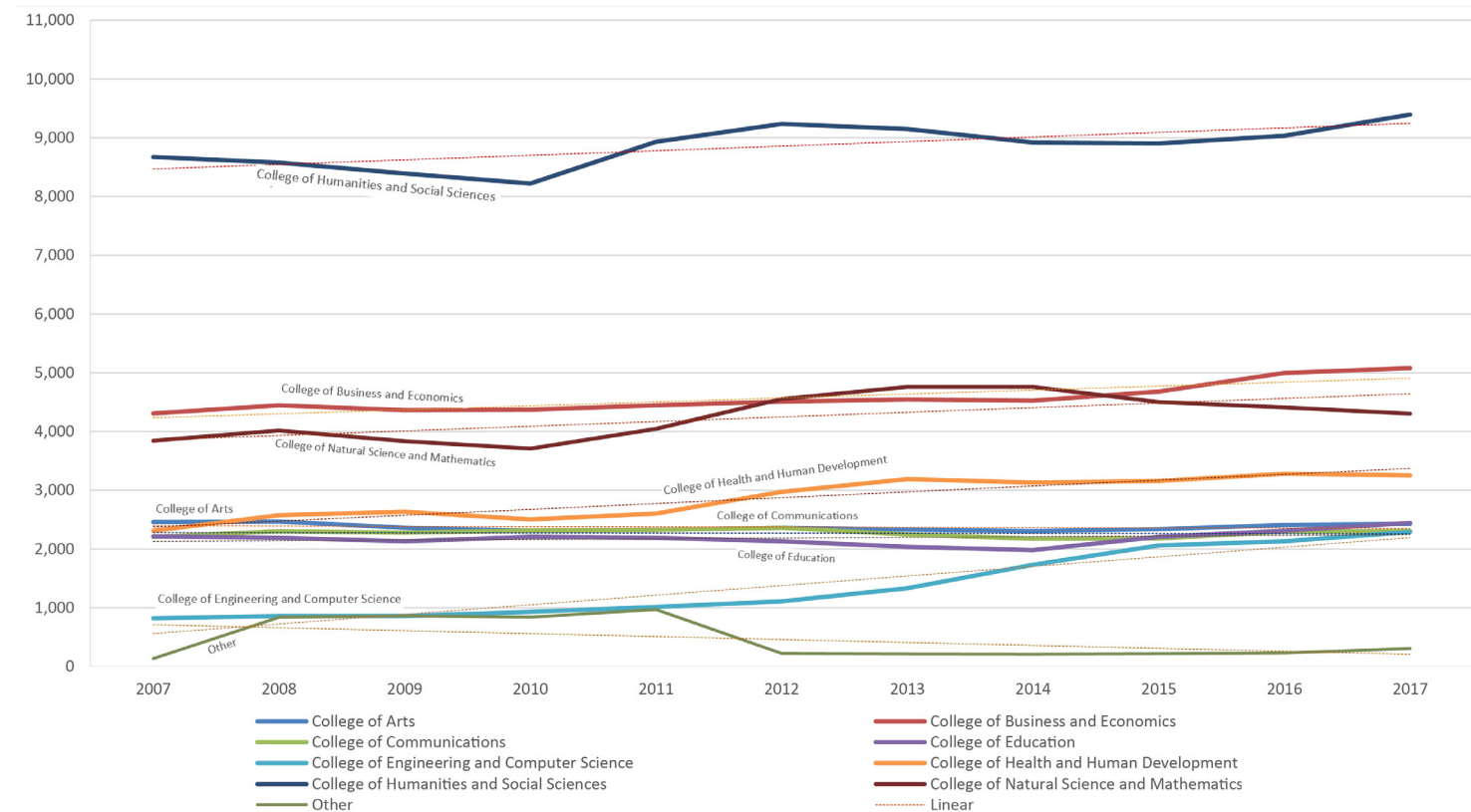


Figure 18. Cal State Fullerton Enrollment by College (Actual)





## Headcount Analysis

With many students attending on a part-time basis, the 32,000 FTES enrollment target will translate to approximately 50,000 people on campus, including students, faculty and staff based on historical analysis of approximate ratios between enrollment numbers, FTES and faculty/ staff.

**Table 1.** Headcount Analysis 2010 - Master Plan

	2010 -11	2011 -12	2012 -13	2013 -14	2014 -15	2015 -16	2016 -17	2017 -18	Master Plan	
Main Campus Academic Year Enrollment (Onsite Face to Face) <sup>1</sup>	23,405	23,941	24,371	24,713	24,902	25,209	25,437	25,690	32,000	32,000
Master Plan Ceiling (BOT Approved in 2003) <sup>1</sup>	25,000	25,000	25,000	25,000	25,000	25,000	25,000	25,000	32,000	32,000
Fullerton Fall Enrollment Headcount <sup>1</sup>	36,156	37,677	38,325	38,128	38,948	40,235	40,439	39,774		
Irvine Campus Fall Enrollment Headcount <sup>1</sup>	2,673	2,612	3,130	3,381	3,687	3,746	4,038	3,991		
Main Campus Fall Enrollment Headcount <sup>1</sup>	33,483	35,065	35,195	34,747	35,261	36,489	36,401	35,783	44,800	46,400
<b>Ratio (Headcount/FTES) - Main campus<sup>1</sup></b>	<b>1.43</b>	<b>1.46</b>	<b>1.44</b>	<b>1.41</b>	<b>1.42</b>	<b>1.45</b>	<b>1.43</b>	<b>1.39</b>	<b>1.40</b>	<b>1.45</b>
Faculty / Staff Headcount <sup>2</sup>	3,296	3,396	3,417	3,658	3,658	3,787	3,883	3,797	4,480	4,640
<b>Ratio (Faculty/staff - FTES) -Main Campus<sup>2</sup></b>	<b>0.098</b>	<b>0.097</b>	<b>0.097</b>	<b>0.105</b>	<b>0.104</b>	<b>0.104</b>	<b>0.107</b>	<b>0.106</b>	<b>0.100</b>	<b>0.100</b>
<b>Total Main campus Headcount<sup>1 2</sup></b>	<b>36,779</b>	<b>38,461</b>	<b>38,612</b>	<b>38,405</b>	<b>38,919</b>	<b>40,276</b>	<b>40,284</b>	<b>39,580</b>	<b>49,280</b>	<b>51,040</b>
<b>MASTER PLAN HEADCOUNT PROJECTION</b>									<b>50,160</b>	

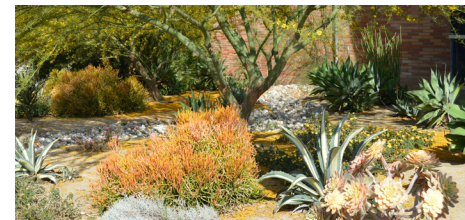
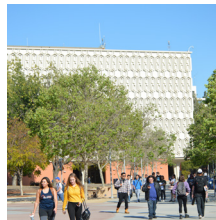
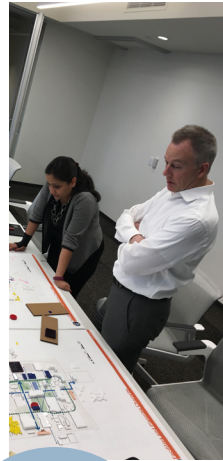
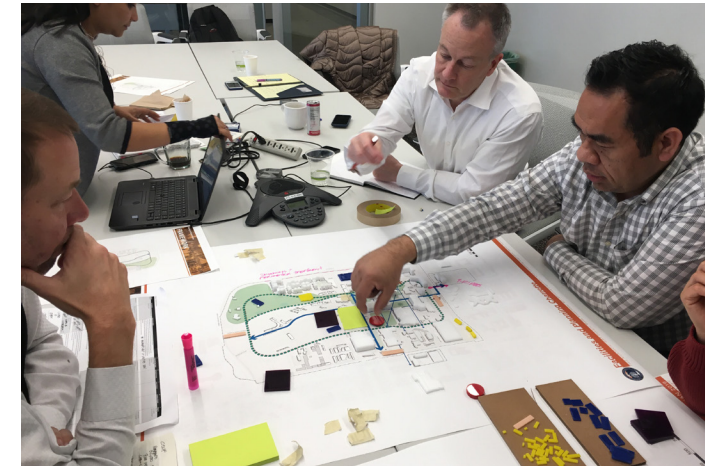
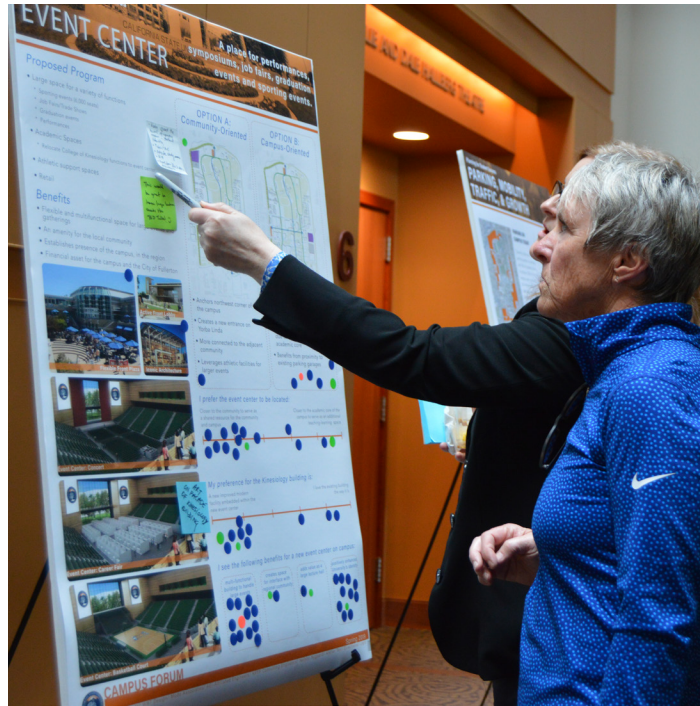
1. Data from CSUF Institutional Research

2. Data from IPEDS HR - Excludes R11(Academic Student Employee) & E99(Non-Union temp employees)





# WHAT WE HEARD



## Kickoff

## Task Force Meetings

## Site Tours

## Forums

## Workshop

## Team Working Sessions

## Surveys



Beginning in late 2017, campus leadership and the master plan consultant team began to mobilize to start the master plan process. Initial steps included information-gathering such as understanding the current state of the campus; the physical state of the buildings and open space; and understanding challenges, deficiencies and opportunities in the context of growth. Activities included

conducting online surveys resulting in over 2,000 responses, touring the campus with the Associated Students Inc. president, interviewing 14 Deans, Associate Deans, VPs and the University President, and holding workshops with the Master Plan Executive Task Force Committee and the Cabinet. In May 2018 a campus-wide forum was held to share initial preliminary thoughts and to solicit

feedback from students, faculty, and community attendees to further understand and define compelling and critical issues facing the campus. Based on insight gained from these events and activities, the master plan consultant team defined key issues and mapped out what drivers and overarching principles should guide solutions. With collaboration with the Executive Task Force, the Cabinet,

and with the campus Facilities and Planning groups and the CSU Office of the Chancellor, the team began testing frameworks and alternative campus plans, refining potential plans based on feedback and discussions. Throughout this process there were also meetings with Friends of the Fullerton Arboretum representatives and in the spring of 2019, two additional open-house style forums

were held to share progress and collect feedback. In-house working sessions among the various disciplines representing the consultant team were also regularly conducted as part of the overall process. With the framework and principles well-established and options culled and refined, by mid-2019 a preferred campus master plan design emerged and was developed to be shared with the public in a

presentation in October. The latter stages of development were coupled with the environmental impact review process. This Physical Master Plan is the result of close collaboration with faculty, staff, and student groups; campus leadership; community outreach; and has included over 30 meetings over the course of more than two years.



## COMPELLING ISSUES + OPPORTUNITIES

Several distinct challenges emerged through the planning process, including both technical analysis and input from students, faculty and administrators. These challenges grow out of the campus' size and location, buildings and infrastructure, enrollment demand, student life characteristics, and values. The Physical Master Plan treats each challenge as an opportunity for enhancement.



### Landlocked Campus

Cal State Fullerton has a finite amount of land to develop on its main campus. It is surrounded on all sides by either residential development or a highway, all of which preclude campus expansion.



### Obsolete Buildings

Many buildings on the Cal State Fullerton campus no longer adequately serve academic or student-life needs of students.



### Lack of Student Amenities

Currently students must leave campus for necessary amenities, such as healthy food options and school supplies, diminishing the potential for sustained activity outside of class hours, especially during weekday evenings and weekends.



### Lack of Housing

Only approximately 5 percent of students currently live on Cal State Fullerton's campus, meaning a majority of students have to commute to school. Given the opportunity, more students would choose to live on campus.



### Connections to and within Campus

Students and faculty expressed the challenges of traveling to campus, including parking, congestion, and lack of mobility choices. There was also dissatisfaction about the ease of movement within campus.



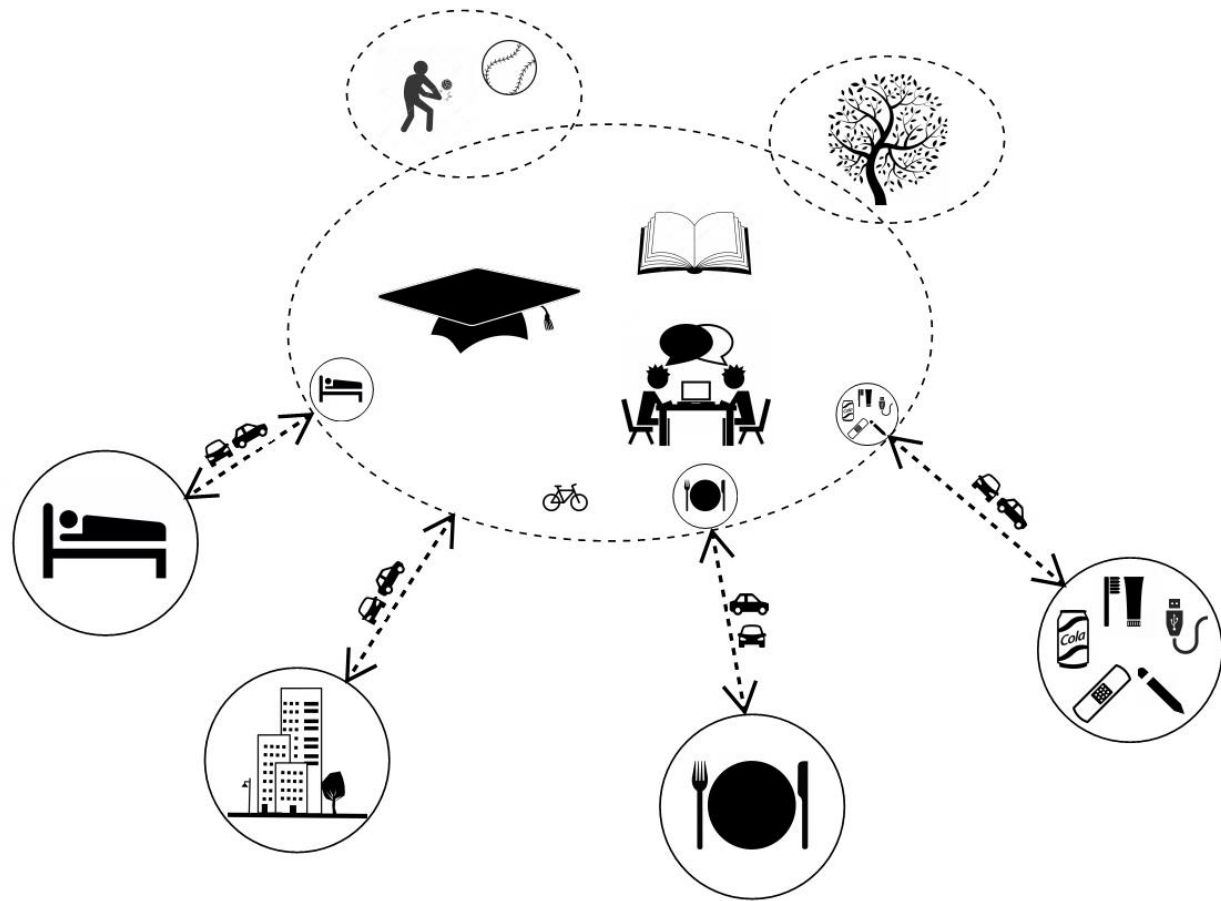
### Quality of Environment

The quality of the campus environment should match the quality of education at Cal State Fullerton, instilling a sense of pride and creating a high quality of student life.



# CAMPUS NOW, CAMPUS NEXT

Figure 19. Campus Now

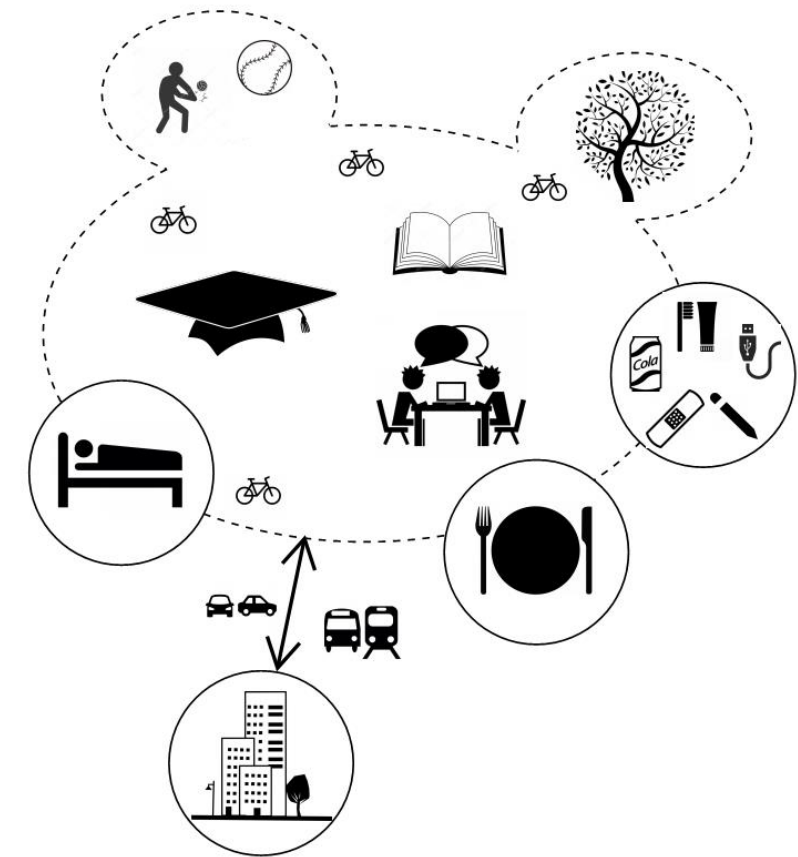


## CAMPUS NOW

Current land use is the reflection of incremental growth over decades, and a general adherence to segregating activities and experience. Students, faculty, and staff expressed the following themes about the campus experience as it exists today:

- There is a perceived physical and social divide between athletics and the rest of the campus;
- A great majority of students, faculty, and staff drive alone between home to campus;
- There is strong interest in removing physical and perceived barriers between campus and the Arboretum;
- A lack of access to affordable amenities forces students to get in their cars and leave campus (often not coming back);
- Students don't stay late on campus due to lack of access to (healthy) food options.

Figure 20. Campus Next



## CAMPUS NEXT

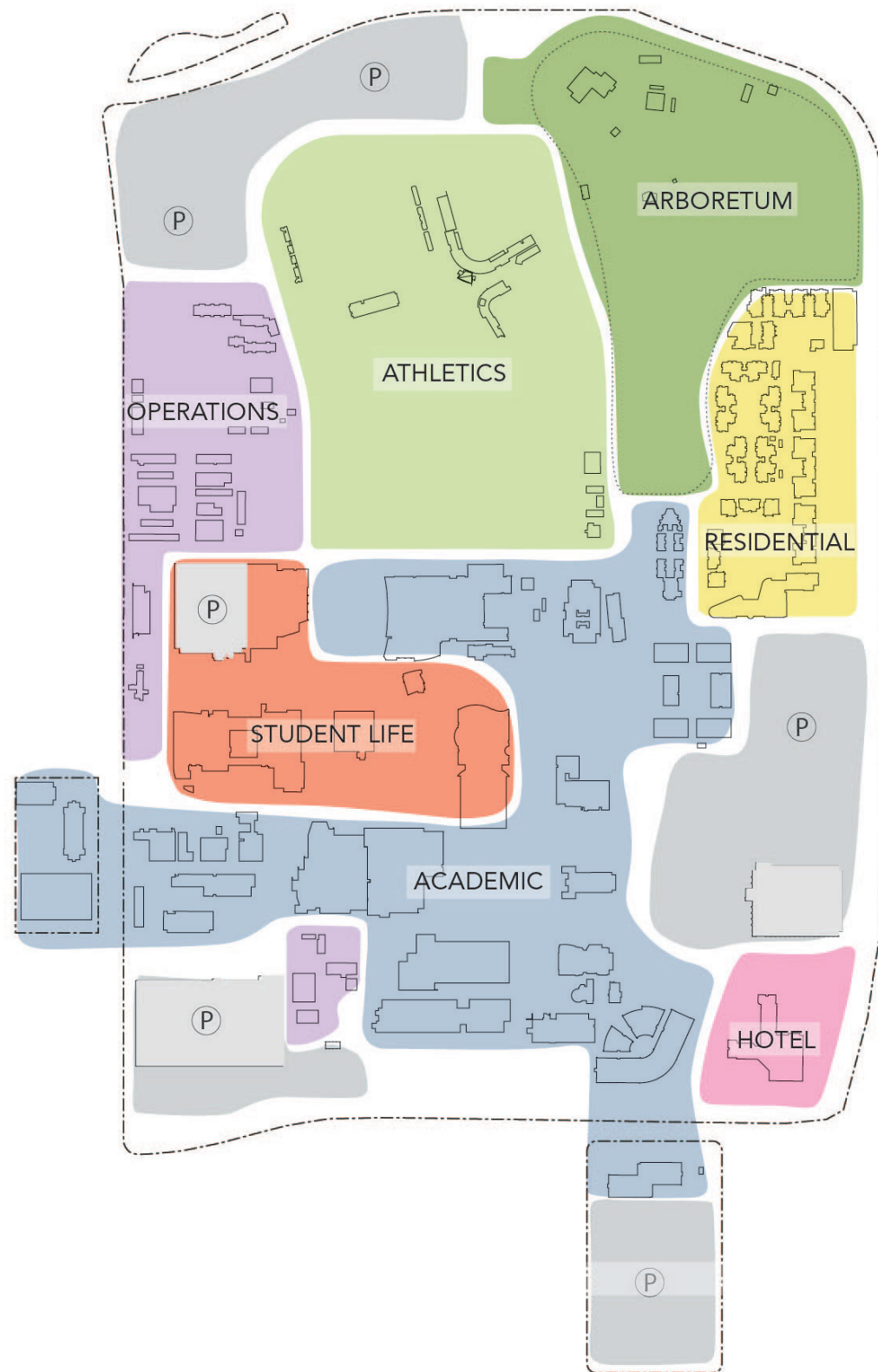
Proposed land use organization is directed by the idea of better integrating daily experiences, connecting more activities and increasing the convenience and economy of both movement and social connection. Feedback from community members provided key direction in developing a master plan for the years ahead:

- Desire to shift from commuter to residential campus;
- Students suggested affordable housing on and around campus as a strategy to reduce the need to drive to campus;
- Encourage a greater diversity of transportation options for those commuting to reduce automobile dependence. Such as strengthening connections to downtown Fullerton Center/ Metrolink;
- There is strong interest in leveraging the proximity of the Arboretum to support departmental curriculum and student life;
- Students want more amenities on campus to increase affordability and walkability over more dedicated parking on campus;
- Students want their campus core to be more walkable and bikeable.



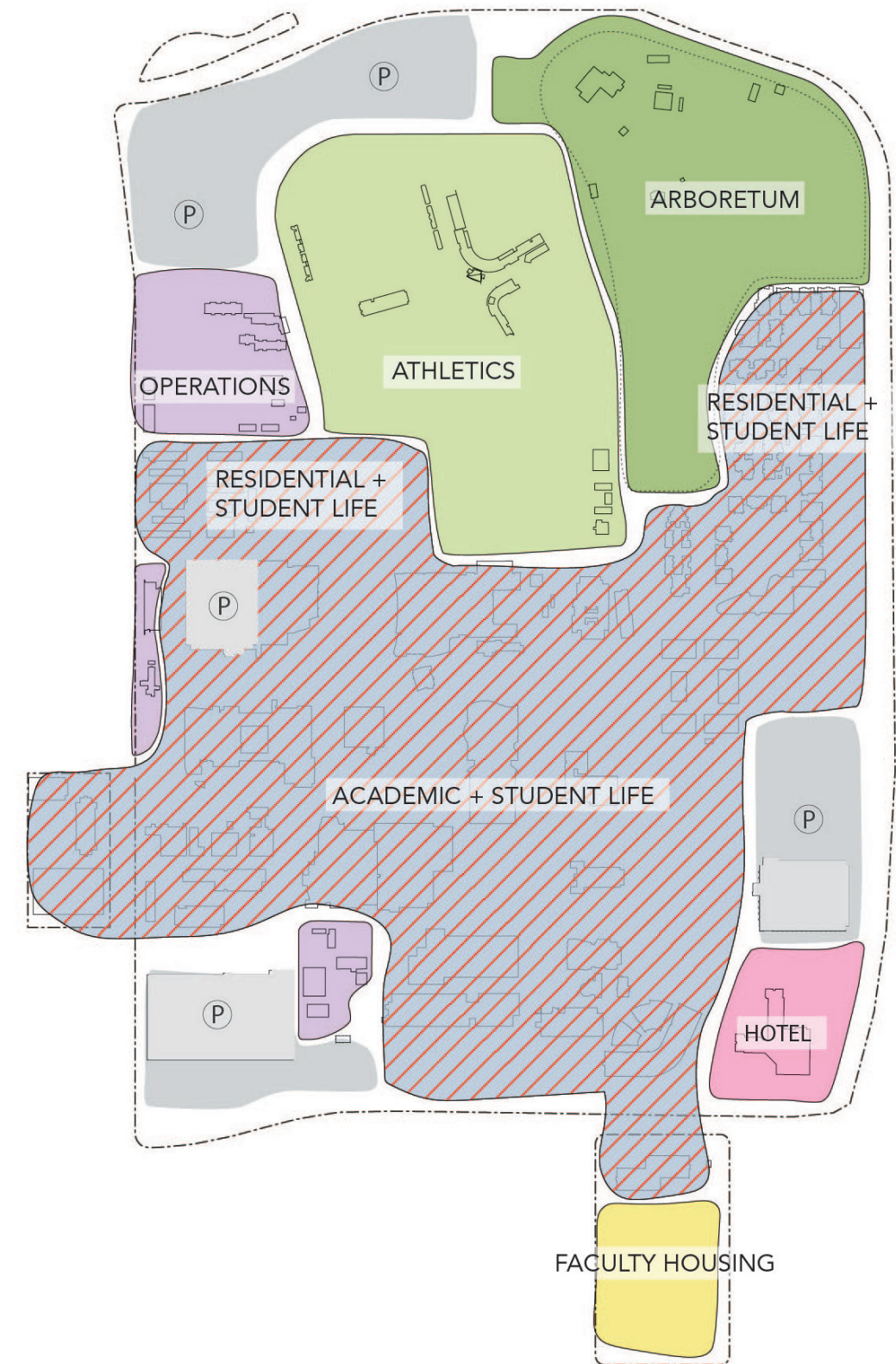
## CURRENT LAND USE

Figure 21. Existing Campus Character Areas



## PROPOSED LAND USE

Figure 22. Conceptual Campus Character Areas







TITAN STUDENT UNION

TITANS

REPUBLIC SERVICES



Chapter

# 2

## WHAT CSU FULLERTON NEEDS

- ▶ Academic Program
- ▶ Student Life / Campus Life Program
- ▶ Sustainability and Infrastructure
- ▶ Vision

The campus looks to gracefully and deliberately accommodate demand and growth, forge a strong infrastructure for student success, spark fundamental organizational and culture changes, and inspire a new level of innovation and collaboration across campus.

This chapter presents Cal State Fullerton's specific needs to support the development of an integrated campus. Needs are presented in sufficient detail to help future decision-makers consider the context of any action they may take from a planning perspective and help them project the impact of their work on future actions.

The projections are based on what we know now and on our best insights of how the campus will and should change. These parameters also give the entire Cal State Fullerton community a sense of the overall direction the campus is heading and allow them to consider how they might fit into that future.

The chapter concludes with a Vision section that establishes the overall direction for the proposed Physical Master Plan presented in this document.

---

Cal State Fullerton is a growing university on a landlocked campus

---



# ACADEMIC PROGRAM / ENTITLEMENTS

In 2015, the California State University (CSU) system unveiled Graduation Initiative 2025 (GI2025) – a system-wide plan that aims to improve graduation rates and bolster the workforce statewide. GI2025's charge for Cal State Fullerton was to increase its four-year freshman graduation rate from 22 percent to 44 percent and two-year transfer graduation rate from 32 percent to 44 percent by 2025 – all while eliminating a historically stubborn achievement gap.

Future enrollment growth is constrained by the state's budgetary limits and capacity of the physical environment. While the 2017 study from the Legislative Analyst specifically calls out Fullerton and its potential for addressing growth through summer enrollment, this is generally felt to be operationally

unrealistic. Many students work throughout the school year, increasing their hours in the summer to cover the cost of tuition. Additionally, the state has a long history of under funding summer term, requiring programs to shift to self-support. The increase of cost to the student, (both real and the fact that financial aid cannot be used) significantly negatively impact overall demand for these courses.

The University is focusing aggressively on improved graduation rates with the GI2025 initiative. While Cal State Fullerton has seen significant improvements in its six-year, five-year and four-year graduations rates (17%, 18%, and 8% respectively), there is more work yet to be done.

The campus' Strategic Plan identifies this issue as a particular point of focus, identifying the following targets/objectives:

- 1 Increase six-year graduation rate by 13 percent for first time freshmen.
- 2 Increase four-year graduation rate by 13 percent for transfer students.
- 3 Double four-year graduation rate for first-time freshmen.
- 4 Increase two-year graduation rate by 16 percent for transfer students.

The campus has laid the initial groundwork to achieving these improvements, including addressing student support, strategic enrollment management, and identifying and correcting bottlenecks within the curriculum.

**Current Deficit:**  
268,483 asf  
**Future Deficit:**  
528,916 asf

Figure 23. Space Needs 2039

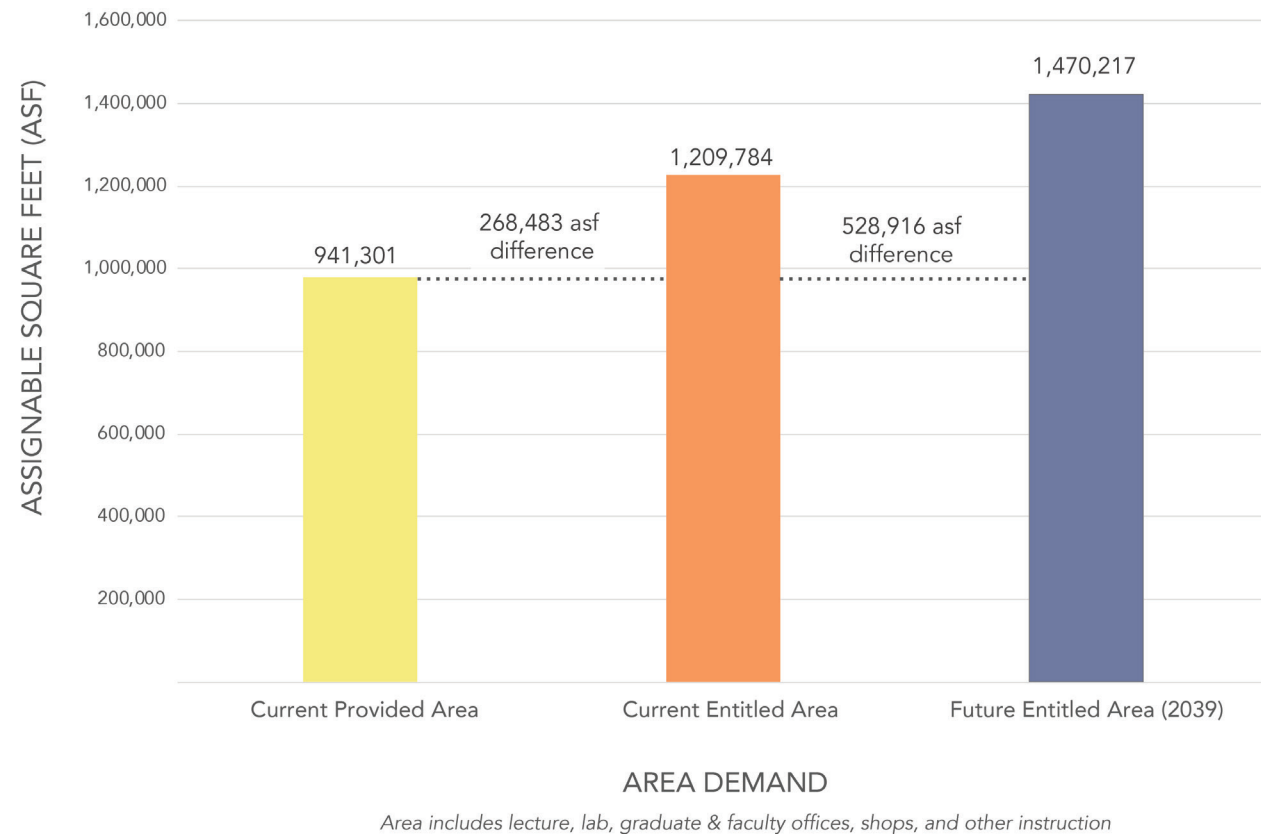


Figure 24. Space Entitlement per FTES by Discipline

ASF: Assignable Square Feet  
FTE: Full-Time Equivalent

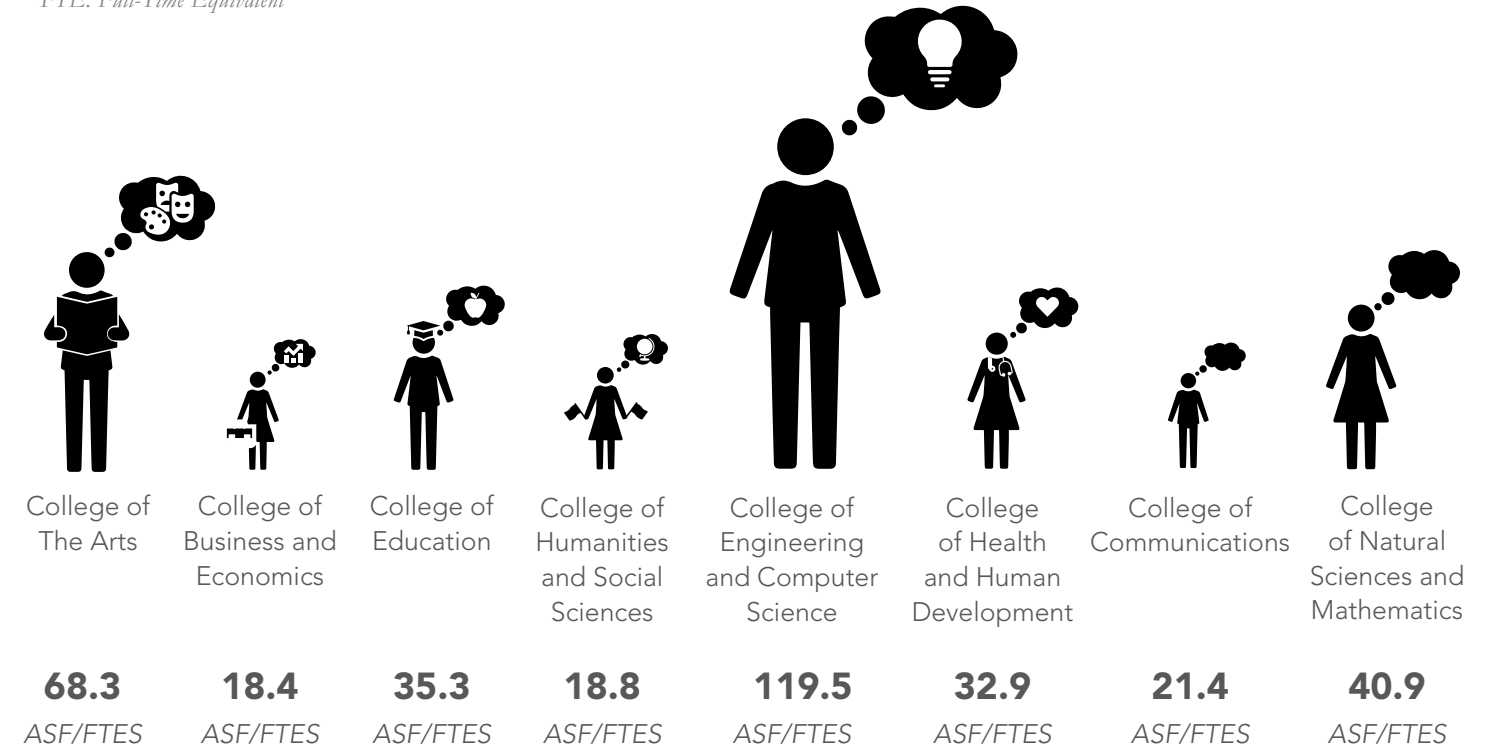
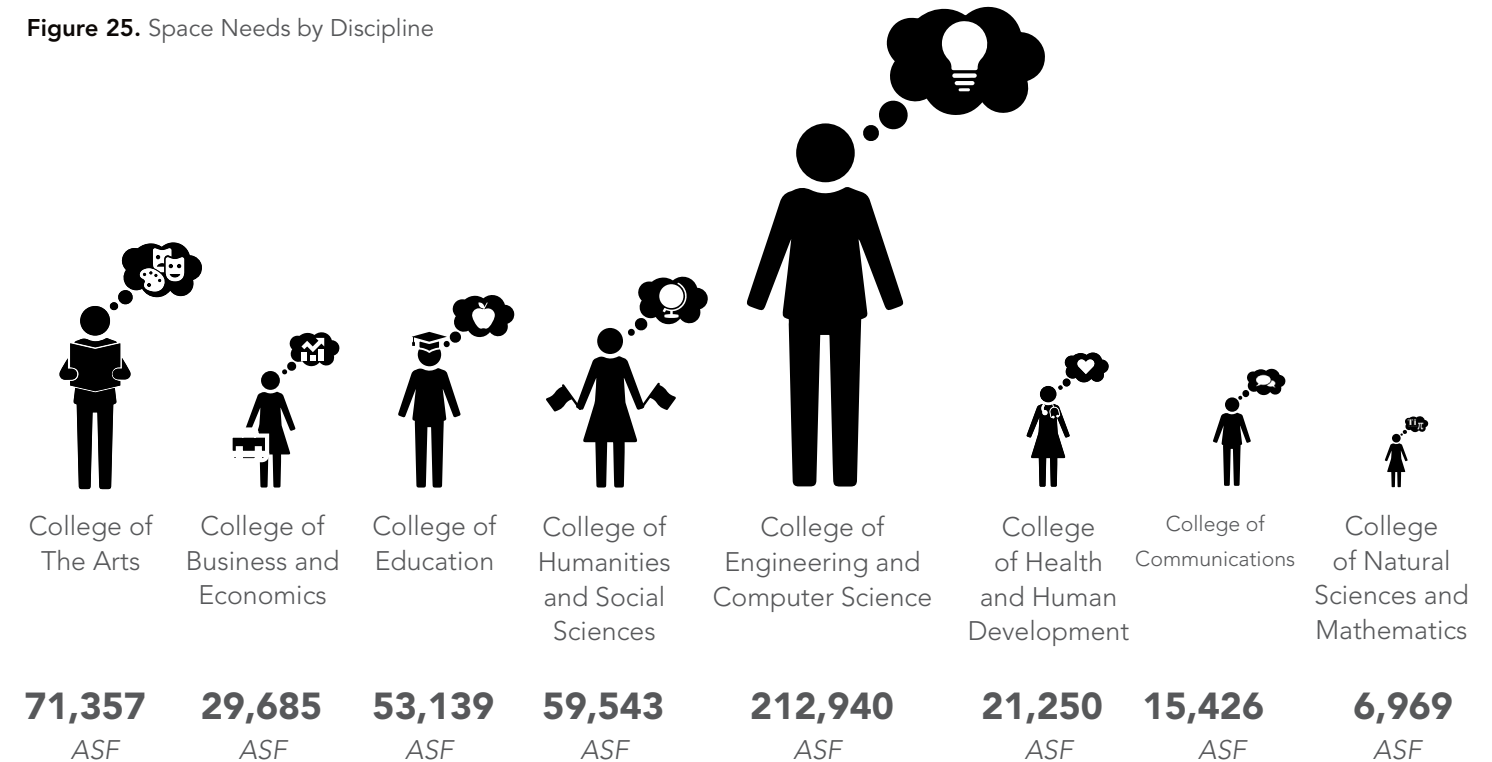


Figure 25. Space Needs by Discipline





**Table 2.** Current Entitlements, ASF: Assignable Square Feet

Instructional Area & Discipline	Total Entitled ASF*	Total Existing ASF**	Need ASF
College of Arts	246,879	205,396	32,788
College of Business and Economics	93,897	46,469	14,713
College of Communications	53,066	33,628	5,782
College of Education	84,429	35,288	36,363
College of Engineering and Computer Science	239,954	69,891	157,335
College of Health and Human Development	141,095	116,385	6,396
College of Humanities and Social Sciences	172,588	84,283	31,266
College of Natural Science and Mathematics	171,224	177,636	-29,325
Other	6,652	-	4,325
Inter discipline	-	172,325	8,880
<b>CAMPUS TOTALS</b>	<b>1,209,784</b>	<b>941,301</b>	<b>268,483</b>

**Table 3.** Master Plan Entitlements, ASF: Assignable Square Feet

Instructional Area & Discipline	Entitled Master Plan Build-out ASF*	Total Existing ASF**	Need ASF
College of Arts	287,575	205,396	71,357
College of Business and Economics	116,875	46,469	29,685
College of Communications	66,053	33,628	15,426
College of Education	104,381	35,288	53,139
College of Engineering and Computer Science	298,675	69,891	212,940
College of Health and Human Development	160,431	116,385	21,250
College of Humanities and Social Sciences	214,823	84,283	59,543
College of Natural Science and Mathematics	213,125	177,636	6,969
Other	8,280	-	5,384
Inter-discipline	-	172,325	53,224
<b>CAMPUS TOTALS</b>	<b>1,407,218</b>	<b>941,301</b>	<b>528,917</b>

\* Lecture Space accounted for at the College Level

\*\* Lecture space accounted for at the Campus Level

## CAMPUS LIFE PROGRAM

Cal State Fullerton has been working aggressively and successfully to increase graduation rates and eliminate disparities for under-represented, first-generation and low-income (Pell) students. With their sights set on becoming the model public comprehensive university of the nation, the University has embedded our commitment to student success, first outlined in the four goals of the 2013-2018 Strategic Plan, and subsequently updated in the 2018-2023 Strategic Plan.

It is with these goals and principles in mind that the campus Physical Master Plan looks to forge a strong infrastructure for student success, spark fundamental organizational and culture changes, and inspire a new level of innovation and collaboration across campus. While the University has sharpened its focus, it has also broadened its definition of success to encompass student well-being, learning, retention, timely graduation, and fulfillment as productive members of our diverse society.

### ASSIGNABLE TO GROSS SQUARE FEET (ASF TO GSF)

The CPDC 2-7 form provides guidance on the required building efficiency for a wide variety of faculty space types. These range broadly, from 59 percent for biological wet labs, to 65 percent for student housing to 72 percent for engineering functions. In an effort to acknowledge the variety of efficiencies, and to accommodate the increasing demand for informal learning spaces within academic buildings, the campus master plan assumes an average

60 percent efficiency across all entitled academic space types, and functions in the arboretum. The Innovation Center, considered to be a highly collaborative center with more informal, unassigned space, is assumed to be 55 percent efficient. As individual buildings are designed, the exact building efficiency will be defined by the function in alignment with State and funding guidelines.

### STUDENT LIFE

To make living on campus viable, it is imperative that amenities are made available to support students during and outside of class hours. If a student has to leave campus during the day to get a healthy meal, buy supplies or even a Band-Aid, they lose opportunities for face time with others, and once a student leaves they are less likely to return to campus at all.

Provisions should include:

- Healthy food choices
- Places to recreate, exercise and relax
- Places for solo and group study
- Appropriate technology
- Adequate security and lighting
- Affordable retail options for basic needs
- Off-hours access to all provisions sprinkled everywhere

With a focus on GI 2025 and student success, the provision of a full complement of support services to create a holistic campus experience is critical. Space types and functions are varied, falling broadly into the categories of recreation, student union, wellness (medical and counseling), libraries and academic

affairs and advising. While there is no exact metric for a specific total area of space that should be provided, the addition of 800,000 gsf represents a healthy supplement to the existing area of approximately 435,000 gsf, which is considered low for a campus the size of CSU Fullerton. Funding for amenity space can be derived from a variety of sources including student fees, State funding and public private partnerships, each influencing the ability to realize the projects based on their varying approval processes.

**Dedicated Student Life Space**  
**800,000 sq ft**

#### Goals of the 2013-2018 Strategic Plan

- 1 Provide a transformative educational experience and environment for all students.
- 2 Strengthen opportunities for student completion and graduation.
- 3 Recruit and retain high-quality and diverse faculty and staff.
- 4 Expand and strengthen our financial and physical capacity.





## 24/7 CAMPUS HOUSING

One of the primary strategies for improving student success is to encourage students to spend more time on campus. Providing housing for students, especially during the critical freshman year, helps retention and graduation rates by removing commuting barriers, allowing for more flexible access to faculty and staff, and creating an environment for extended hours of learning and participation in student clubs, study groups, and engaging with other students.

New student housing facilities need to create places where people want to live and learn and should include places to study outside of the dorm room, places to hang out, and places to meet in groups or to study or socialize. Campus living should also include access to places to recuperate, places to be quiet, and places to exercise and recreate.

---

**Additional  
Student  
Housing:**

**2,400 beds**

**Faculty  
Housing:**

**350 units**

---

## EVENT CENTER

The addition of an Event Center looks to build community through institutional activities that encourage town and gown engagement, add vitality to campus life, elevate the potential of the University's athletic program and create a rich hub for student life.

The Event Center becomes a focal point, visible from Highway 57 and prominently located within the academic core. Set back from the proposed Innovation Center, the Event Center creates a campus life forecourt that lends itself to community activities such as pre-event assembly space, career fairs, and interactive market space encouraging the Town & Gown relationship.

Along with providing active athletic courts, the program could include meeting space which will benefit

many new and enhanced program relationships. Central to the success of the Event Center will be the inclusion of academic and student life programs so that the facility is an active hub on campus with a high utilization and not just for athletic competition. Intramural sports would have access to the facility, leveraging the adaptable court seating to create a large open flat space, which could also be used for concerts, commencement and other large assembly events.

Parking will be provided on grade and in the adjacent elevated parking structure to the east. The existing and future parking structures could be conveniently connected with a pedestrian bridge and linked to the Event Center.

---

**Event Center  
Size**

**6,000 seats  
(athletics and  
recreation  
function)**

---



## INNOVATION HUB

With a focus on student success and recognizing a shift in teaching and learning methods by engaging inter-disciplinary departments, the Innovation Center will act as a catalyst for cross campus collaboration. Program details and areas of focus will be determined in time; however three fundamental organizing concepts can be considered.

### *Promoting Multi-Disciplinary Learning*

The challenges we face are becoming more complex and academic institutions are recognizing the power of crossing traditional academic lines to best respond. This is fueling the creation of innovation centers that drive cross-pollination and fuse creative fields like computer science, math, design, engineering and others to expand potential for developing new products and real-world applications.

### *Driving Entrepreneurship*

Technology has made it easier than ever before for students to start and launch companies. Learning institutions are responding by developing incubator programs along with facilities that harness students' entrepreneurial drive and creative passion. These centers are often highly flexible and blur the lines between life and work in a way that gives students 24/7 access to technology and support as they build and launch companies. They also help students build evidence of preparation for employment, something that more business and industries are looking for from graduates.

### *Fostering Industry Partnership*

Other institutions are turning to innovation centers to create and enhance industry partnership. This model leads to facilities where businesses can be embedded and work in tandem with university business and engineering schools to create new products and services. These partnerships create mutual benefits: learning experiences for students who, in turn, lend their talents to solving challenges facing business and industry. An "open lab" initiative can exist, where regional business and industry leaders, faculty members and students engage in research and development as teams. Industrial tenants can occupy part of the new building and have access to university research space and equipment. This learning model will promote collaboration among academia and industry, offer students real-world experience and support the growth of manufacturing in the region.

---

Innovation Hub  
Size  
**73,000 GSF**

---





## HEALTH AND WELLNESS

Cal State Fullerton enjoys the benefit of very comfortable weather in support of outdoor activities most of the year. Further, the campus is composed of a diverse array of green, open spaces, a world-class arboretum and some campus open spaces that invite outdoor living. The Physical Master Plan builds on those attributes on several levels:



- Open pastoral space and the Arboretum should be strengthened through greater programmatic connections and through preservation of spaces and pathways that invite reflection and regeneration. These support student mental health and the formation of relationships outside other aspects of student life;
- Student housing should be located near open space and pathway systems that invite informal use on a daily basis. Open space placement should complement current housing locations on campus;
- In the academic core, there are open spaces and pathways that serve clusters of buildings and each can be developed in a way that best serves the constituencies that surround them. This will give students many options for experiencing campus and finding spots that resonate with their needs. Informal learning and social spaces should be located at the ground plane around these campus courtyards or green spaces to help enliven them across more hours of the day. Further, many could be dedicated to occasional celebrations or displays of ongoing work;
- The historic ring road should be reinvigorated for pedestrian and bike use and inter-campus circulation. It can be incrementally upgraded as resources are made available. Of particular interest is the idea of using the path as a teaching tool for demonstrating biology, botany and geology for a start and perhaps creating a connection to more substantial efforts for sustainable living hosted by the Arboretum;
- The pedestrian system should be protected from car and truck traffic.

Non-powered modes like bicycles, skateboards should be allowed with decreasing opportunity at the campus core, lowering the likelihood of accidents and calming the atmosphere at the center of the community. Students and faculty arriving to campus by public transportation should be able to find easy access to the campus core from transit hubs, helping ease the basic stresses of the comings and goings of campus life.

## SUSTAINABILITY AND INFRASTRUCTURE STRATEGIES

### MOBILITY

Cal State Fullerton has traditionally been a commuter campus, but this is changing as the University looks to accommodate future growth by housing more students on campus. When a campus plans to increase enrollment, CSU policy requires that updates to the Physical Master Plan include a Transportation Demand Management (TDM) plan to improve campus access by modes alternative to driving alone and parking on campus. The Office of the Chancellor's Sustainability Policy and the CSU Climate Action Plan direct CSU campuses to reduce GHG emissions from University-associated transportation through promotion of alternative mobility options. The Sustainability Policy states that students, faculty, and staff are ensured access to a range of safe, affordable, and convenient transportation options. This vision is reinforced by the goals of the CSU TDM Manual that includes the following:

- Encourage the use of non-auto modes,
- Ensure equitable access,
- Preserve valuable campus land for academic uses and
- Promote environmental sustainability.

The CSU system is also transitioning its transportation impact study guidelines for new development to be compliant with California Senate Bill 743 (SB 743). SB 743 requires that entities submitting traffic impact studies for CEQA review replace the core metric of vehicle Level of Service



(LOS) with Vehicle Miles Traveled (VMT) for assessment of transportation impacts by July 1, 2020. VMT provides a far more useful tool for advancing sustainability by removing barriers to infill development by tying a direct link to vehicle travel and GHG emissions.



## CLIMATE CHANGE AND CSU MANDATES

In 2006, California passed the Global Warming Solutions Act, known as Assembly Bill (AB) 32. AB 32 requires California to reduce its greenhouse gas emissions levels to Year 2000 levels by 2010, to 1990 levels by 2020, and to 80 percent below 1990 levels by 2050. The California State University Sustainability Policy (May 20-21, 2014) echoes AB32, setting Policy Goals for greenhouse gas emissions that meet and exceed AB32 targets: reduce GHG emissions to 1990 levels by 2020, and 80 percent below 1990 levels by 2040. Cal State Fullerton has set a target carbon neutrality date of 2050, including scope 1, 2, and 3 emissions.

2040 falls just beyond the horizon of this Physical Master Plan, so buildings constructed or renovated under the guidance of this document bear a significant responsibility to contribute GHG savings. In order to meet these goals, all buildings, both new and existing, must eliminate fossil fuel combustion and reduce energy consumption as much as possible. During this time, the campus must continue its transition to renewable, carbon-free electric sources.

The CSU Sustainability Policy also sets reduction targets. The Sustainability Policy requires that buildings are designed and built to LEED Silver equivalence, and that campuses shall strive to achieve LEED Gold or Platinum.

This next phase of Cal State Fullerton's growth opens the potential for **Fullerton to be the "demonstration campus" for sustainable growth** for the CSU system.

### Energy

Reducing greenhouse gas emissions by 80 percent below 1990 levels by 2040 will require action on the part of Cal State Fullerton and its contractors. Procuring clean electricity, including maximizing on-site renewable energy sources (such as photovoltaics), is the logical first step. But with currently available technology, it is not possible for the campus to generate 100 percent of its electric demand on-site using photovoltaics cells, even by theoretically covering the entire campus with them. If a biogas source is identified (such as sewer gas or methane generated by a biodigester), the University may consider on-site fuel cells to generate electricity. The University will have to procure carbon-free electricity or invest in off-site generation to make up the remaining demand.

In order to meet campus sustainability goals, all new building construction needs to utilize an energy use intensity (EUI) performance based procurement process. It is recommended that the design teams of future buildings provide circulation areas (stairs and corridors) on the perimeter exterior of the building; designing circulation areas that are open to the exterior can further reduce utility demand. Suggested Energy Use Intensity (kBtu/SF) targets for all new buildings types are listed below –

- Academic building (non-labs):  
Min (30) Stretch (24)
- Housing: Min (30) Stretch (27)
- Teaching (lab) building:  
Min (111) Stretch (80)

Reaching the 80% target will not be possible without eliminating combustion of fossil fuels from all buildings, new and existing, along with the central plant.

It is likely that new residential buildings will not connect to the campus district energy system. Because of the lower energy use intensity of residential buildings (compared to other program types such as classroom or lab), it is possible for them to be net-zero with respect to site energy use, a goal that designers should aim to achieve.

Given the large capacity of photovoltaic arrays currently on-site, and the likelihood for more, Cal State Fullerton should implement a microgrid with on-site battery electric storage. The use of these batteries can be optimized to draw down at the time of day when the embodied energy of electricity coming from the grid is at its highest. Additionally, a microgrid could allow portions of the campus to remain powered even if the utility shuts off electricity to the grid.

### Water

The CSU Sustainability Policy also sets reduction targets for water and LEED. For water, campuses are to reduce water consumption by 10 percent by 2016, and by 20 percent by 2020. For Cal State Fullerton, this means maintaining a reduced water consumption target even as the population of the University grows.

In order to meet the CSU Sustainability Policy target of reducing water consumption to 20 percent below 1990 levels by 2020 (CSU Sustainability Report 2014), Cal State Fullerton must hold on to recent improvements in water conservation and maintain that low level over the next 30 years, even as the campus population grows. Given the scarcity of water in Orange County, Cal State Fullerton should demonstrate leadership by setting its own stretch goal of reducing water consumption to 30 percent below 1990 levels by 2030.

Replacing turf with native and adaptive vegetation has been popular with the campus community. Cal State Fullerton should continue this momentum by replacing under-programmed turf and hardscape areas on campus with low-water-using native vegetation and expanding the Arboretum.

Cal State Fullerton should implement a district-scale blackwater reclamation project to generate reclaimed greywater on campus, distributed through a campus-wide "purple pipe" (so called for the color that plumbing code requires for reclaimed water piping). Irrigation should be switched over to reclaimed water. New buildings should be dual plumbed to flush toilets and urinals with reclaimed

water. For existing buildings, it may not be feasible to retrofit purple pipe supply unless the building undergoes a substantial renovation. It is likely that existing buildings will continue to be served by potable water only.





# VISION

Master Plans are special opportunities to create strategic change, to align place and purpose and to address the most important drivers that will define a campus identity and craft that place in which a culture can evolve and distinguish amongst others.

There are as many definitions of a Master Plan as there are people in the room, sometimes more.

This Master Plan comes on the heels of the Academic Master Plan (2018) that paints a picture primarily in terms of:

1. Expanding enrollment and understanding demographics and lifelong learning styles;
2. Students authoring their experience and driving success, including the growing role of research-affected student and faculty relationships; and
3. Outreach to the business community, all part of building a resilient and sustainable enterprise.

What has changed and why is that important?

- Student demographics, lifestyles and learning styles;
- Team-based, real time work, learning 24/7 in social relationships;
- Pro-active authorship of an academic career;
- More hands on, more research-based learning, more cross disciplinary opportunity;
- Serving traditional and continuing education-based students;
- Acceleration of understanding and bolstering persistence ;
- Creating a culture that relies on informal learning and the creation of community by virtue of housing, and;

Figure 26. Elements of Physical Master Plan Vision



- Demands created by the employment market in search of the best graduates.

Do these things affect placemaking?

Yes. Enough has changed since the 2003 Physical Master Plan that physical changes to campus will help increase academic performance. We know that our students understand the value of convenience, of connecting

with others and in the exploration of shared ideas. When the students of the future make a choice about where to spend their time and money, they will decide based on greatest value.







## IDENTITY

The University as a whole and its individual colleges seek to create an identity. Especially in a climate like Orange County, there are opportunities to blur the boundaries between inside and out to create a beginning or “front porch” for each college facility to reflect academic, social, physical, and cultural activities within.

A focus on maximizing accessibility will help create a clear identity and a place of inclusion. Identity for a campus can include graphic and visual identity throughout the campus, to buildings and departments, and to site features, and also includes a sense of belonging and pride.

### Provide/create sense of place

- A sense of pride and a desire to show off the work and culture;
- Highlight the ties that bind the campus and the community, which could be exercised routinely and episodically in the course of an academic year; and
- The landscape planting on the campus can be cohesive and support the learning needs of the academic programs.

### Improve connection at edges

- Create better physical connections to provide safe travel to events from off campus and provisions for evening campus use; and
- The Arboretum facilities must be updated and be made more effective for tomorrow’s needs.

### Improve wayfinding

- Campus pathways and building arrangements could be more intuitive to navigate.

### Improve connection between indoor and outdoor

- Explore changes to ground floors of buildings, hallways, and classrooms configuration to support visual transparency into activities with building and vice versa;
- To support informal learning, there is an interest in any site art reflecting STEM students and topics.

### Improve Transparency

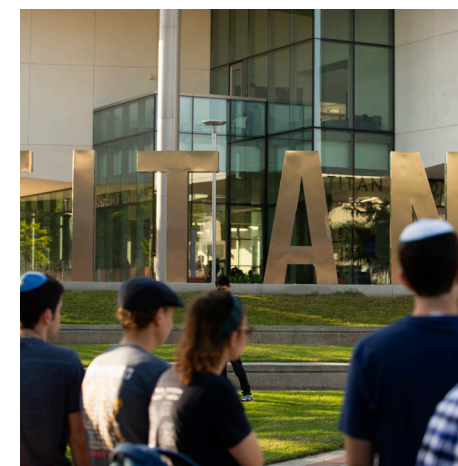
- Break down the artificial barriers that hide the community members from each other;
- Introduce features that will make campus more appealing to walk across;
- More interest in the outdoor campus environment would get people out of their buildings.

### Emphasize Student-Centric not Car-Centric Movement

- Enhance pedestrian safety;
- Improve connectivity and cohesion across campus. There is a social division between academic and athletic department;
- Lack of designated bike lanes discourages bike use;
- Students prefer to use their scooters, or walk.

### Improve Connection to remote parts of the campus

- There is a general lack of awareness of the size and distribution of enrollment across the colleges;
- There is a desire to create meaningful relationships as manifested by adjacencies and collaboration;
- Increase access to power plugs, appropriate furniture, and wi-fi;
- Put sustainable building and landscape features on display;
- Take advantage of California’s climate with a priority of Open Space.



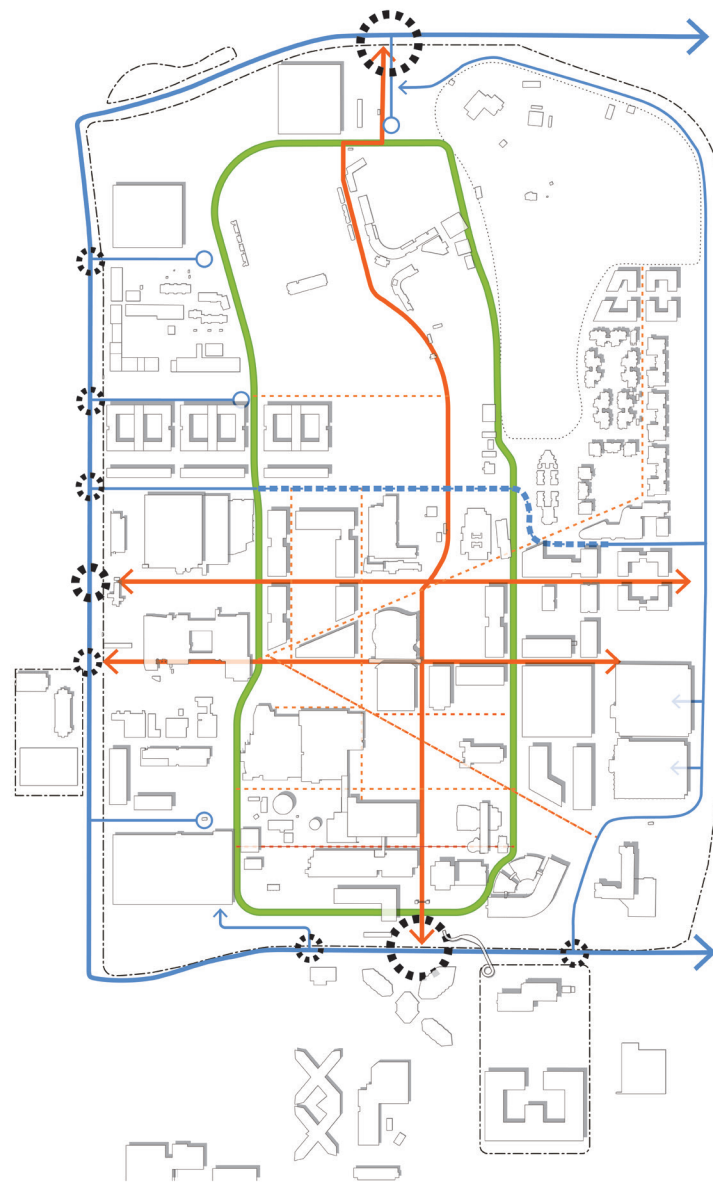


## CONNECTION

Strong physical connections foster important relationships and educational opportunities. Connections on a campus can mean feeling that all regions of a campus are part of a whole, that getting from one part of campus to another is without boundaries, and that traversing campus is clear, safe and inviting. Connections can also mean how the campus connects with the broader community.

There is a desire to create meaningful relationships as manifested by adjacencies and collaborations on campus and in connections to the community. Something like "neighborhoods" would help highlight the academic organization of campus and provide clear destinations during events such as Art Week, Jazz Week, the Engineering Fair, etc., and including campus events that attract large off-campus participants, such as performing arts events.

1. Improve wayfinding and legibility of campus internally and at the intersections to the community
2. Provide a framework for diverse modes of transport
3. Streamline commute and transportation- less time in their cars and more time teaching/ learning
4. Connect to Fullerton Downtown and regional transportation








-  Intersection / Entry way
-  Primary Pedestrian Pathway
-  Secondary Pedestrian Pathway
-  Green Loop
-  Auto Access

Figure 27. Connectivity Concept for the Physical Master Plan



## ACTIVATION

Activation in the context of a campus environment means extending the life of the campus beyond typical class hours and making the campus accessible for its diverse population of students and the community at large. It means the campus is a place where things are happening and can happen and that people want to be there.

There is a desire to take advantage of California's climate while also breaking down broad open spaces to create smaller, more intimate outdoor spaces. Students, faculty and staff all value the ability to use space outside for all kinds of uses: gathering, studying, eating, displays, fairs, celebrations, art and artifacts. A 24/7 campus has become a necessity by students and faculty alike, seeking more amenities to support current campus lifestyles, including student clubs and other organizations that meet after class hours, and to increase the feeling of vitality on campus.

1. Create campus hangout places of quality
2. Provide 24/7 amenities
  - Sports and Recreation
  - Library and Study Area
  - Labs and Workshops
  - Food and Retail
3. Increase utilization of campus land
4. Housing on campus
5. Safety
  - Pedestrian Crossings
  - Bicycle Access
  - Human/Belongings
  - CPTED



-  High Density of Activity

Figure 28. Activation Concept for the Physical Master Plan





## LEARNING

Core to the function of a campus, the physical environment must support academic programs, instill the desire to be there and to learn, and provide the means to teach and learn in the most effective and contemporary ways. This includes removing distractions, allowing for spontaneous interaction, having safe and comfortable spaces to think and decompress – for students and faculty alike.

Nearly every Dean saw a potential benefit of the idea of a student-focused non-departmental building on campus, as well as an “Innovation Hub”, to support multi-disciplinary collaborations and innovation space for special projects, simulation-immersive experiences and maker-space that would be used by all colleges. This would enable students and faculty to drive their ideas further in a way that would be more space efficient for the entire university. It would be a “Buzz driver” and would support active learning – students working in small groups, project-based learning, research-as-teaching and more work with business and industry partners. Currently on campus these types of spaces are for the most part makeshift and not conducive to driving exceptional scholarship.

To support informal learning there is a desire for creating appealing in-between spaces: spaces at the threshold to classrooms in hallways and spaces immediately inside and outside building entrances to allow for students to hang out, wait for friends, wait for class to start, study or review, and interact with faculty and other students. Outmoded buildings have very different approaches to the teaching/learning experience based on what was in place 50 years ago..

Emphasis is now on active learning as the basis for every college’s approach and yet nearly every building is designed for the sage on the stage. Further, the role of informal learning is the new measure of accelerated student learning and that is hard to do when most buildings are designed with six-foot double loaded corridors and no front door.



Figure 29. Academic Concept for the Physical Master Plan



## VALUES



Putting on display the values of the student body and of the faculty and staff is a priority. This includes celebrating the diversity of campus, sharing its commitment to sustainability and social equity, and having the campus reflect the value that is placed on the students by faculty and staff.

Students, faculty and staff share the values of sustainability and socio-economic equality and in reflecting those values on campus. Additionally, students identified interest in providing a focus on health

and wellness and on displaying and celebrating student work. Club spaces and learning spaces specifically for graduate students, group spaces, quiet spaces, studio space for theater majors, and space for commuters were all articulated as ways to make the campus more supportive of informal learning, to reflect students’ contributions to campus life, and to support a sense of belonging.

The condition of existing 1960s-era and some other buildings cannot support today’s models for teaching and learning, and they do not reflect

the value that the Cal State Fullerton wants to express for its students.

Facilities offered on a campus must reflect a generation that grew up with technology. Students need more indoor and outdoor social and study spaces, equipped with appropriate furniture, power outlets, and Wi-Fi. “All you need is shade, power and data, ... and coffee.”







## Chapter

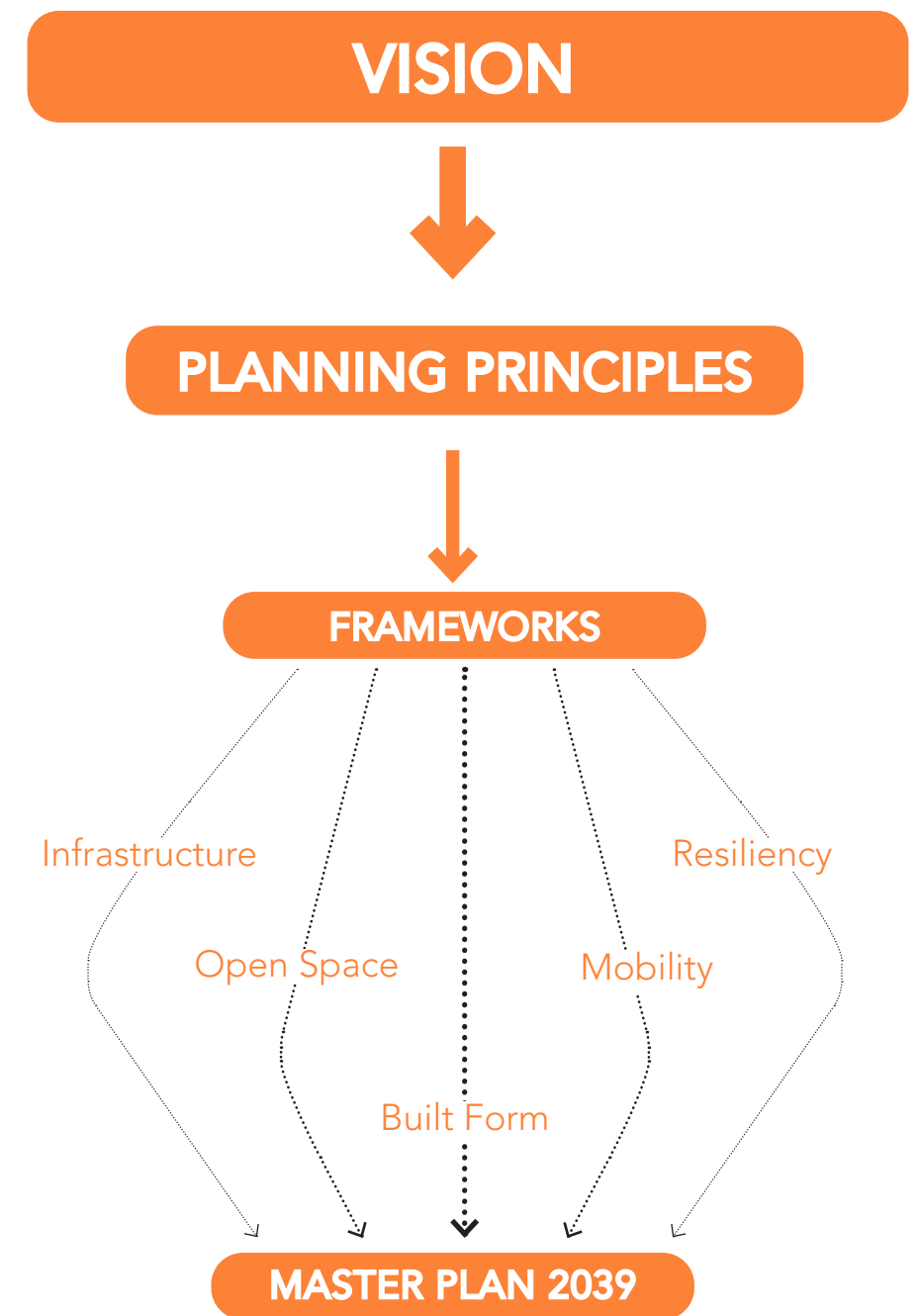
# 3

## HOW TO GET THERE

- ▶ Planning Principles
- ▶ Design Guidelines / Frameworks
- ▶ Built Form
- ▶ Open Space
- ▶ Mobility
- ▶ Infrastructure
- ▶ Resiliency
- ▶ Implementation

Each component of the Cal State Fullerton Physical Master Plan is driven by a vision that has been established through two years of engagement with the students, faculty, and academic staff. The vision, summarized at the end of Chapter 2, is largely qualitative, focuses on the guiding values of the institution, and does not have explicit physical forms.

In this chapter, the physical manifestations of the master plan are outlined. The vision has been translated into five planning principles to help judge the validity of proposals. These principles set the stage for an organizing framework and provide guidance for all of the individual components of the Physical Master Plan.





# PLANNING PRINCIPLES

Figure 30. Six Planning Principles for the Physical Master Plan



## Commuter to Residential

A major shift in the proposed Physical Master Plan will be to prioritize strategies to encourage students to remain on campus including providing more student housing and improving amenities on campus, which in turn will help create a 24/7 campus and reduce the pressures of needing to commute.

## Supporting Academic Needs

The Physical Master Plan identifies additional academic spaces, both formal and informal, to allow classes to be offered at intervals to support demand and to create classroom and lab environments to support current modes of teaching and learning. The Physical Master Plan also identifies the required amount of academic space to support anticipated growth.

## Quality Open Space Environments

The Physical Master Plan introduces frameworks and strategies to enhance open space environments and create more meaning in their organization, relationships to the building environment and to each other. This includes planning for a variety of open space types, improving access and connection to existing open spaces and the Arboretum, and planning for deliberate connection to circulation paths and to the buildings' front door.

## Making Way for Transformation

In order to fully accommodate growth, outmoded and poor-quality buildings must be replaced with new structures that can accommodate programming that supports academic needs. As buildings are being taken offline, displaced programs will be shifted to new or renovated facilities. The selection of building candidates to be removed took into account condition, age, and density of use.

## Leaving space for future growth

The Physical Master Plan envisions that growth will continue for Cal State Fullerton, beyond the time scope of this plan, and aims to provide flexibility in the future by proposing higher-density projects and leaving other sites undeveloped for potential future uses. Creating more density on the sites that are developed also provides some economy of scale, gaining more programmable area in building projects and capturing associated construction costs and allowing for flexibility and growth within the buildings themselves.

## Sharing resources across the campus

This Physical Master Plan seeks to create opportunities to share resources across the campus to better utilize space across all academic disciplines. This strategy also provides flexibility as demands for any given use fluctuate over time and includes informal learning spaces in all buildings that can be used by anyone.



## DESIGN GUIDELINES/FRAWORKS

Building upon the great work published in the 2003 Master Development Plan, this Physical Master Plan elevates components of those guidelines that resonate with current thinking and remain applicable to future development and adds organizing frameworks that further direct future improvements to the physical environment to support the mission of the University.

The 2003 MDP makes a distinction between “foreground” and “background” buildings and defines applicable design guidelines for each. “Foreground” buildings are those meant to serve as a focal point on the campus, buildings that accommodate a singular use, or buildings whose internal functions require extraordinary facilities or forms. ‘Background’ buildings are those which are subordinate to the larger campus, those whose features and functions are not showcased, or those whose sites are in less visible areas of the campus.

Purpose-built structures in the academic core and buildings that are prominent to the perimeter of campus would typically be identified as foreground buildings and would be expected to be more architecturally distinctive than other campus buildings. Their massing may be more expressive or showcase special architectural features, materials or fenestration. Foreground buildings proposed in this Physical Master Plan include the Event Center and the Innovation Hub and could also include other academic buildings as identified by campus leadership in the future.

Buildings such as student housing or facilities buildings would typically be considered background buildings and their forms would be more rectilinear with subtle architectural features, and articulation would be more functionally expressive (i.e. stair towers, sunshades or balconies). In this Physical Master Plan, background buildings would include student housing and support buildings in the Arboretum and structures associated with mobility hubs.

Regardless of whether a structure is considered a foreground or background building, massing should be articulated to create a comfortable relationship between the scale of a person and the scale of the building. On the existing campus, this is often accomplished by a building’s architectural or structural expression rather than applied decoration, and building elevations are brought into pedestrian scale using more articulated or open ground floor elevations. New buildings should employ architectural articulation to create visual interest, incorporate surface effects in ways that are consistent with existing adjacent structures, and consider changes in material, color, or other architectural features to visually articulate or activate a building elevation.

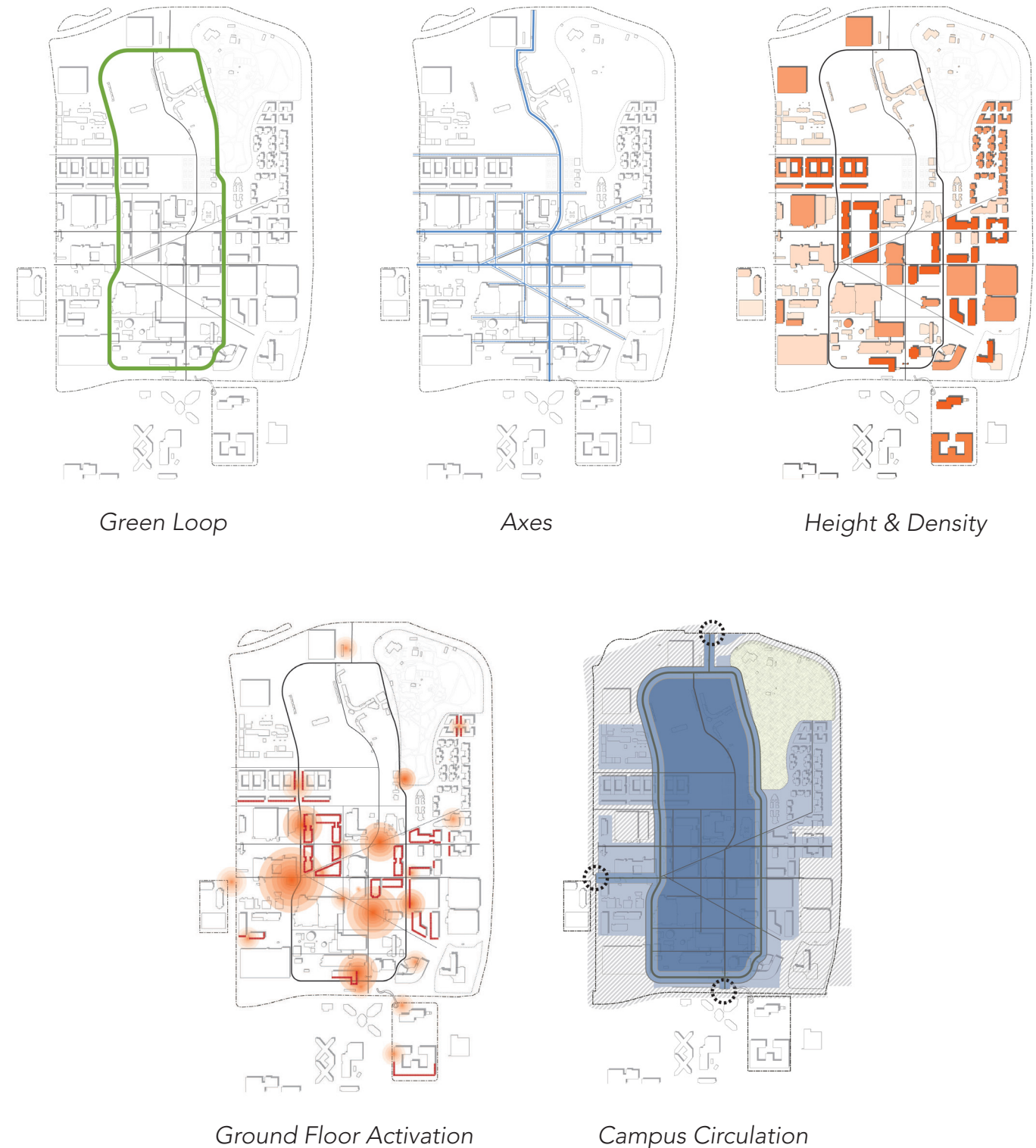
Existing campus building façade materials are predominantly concrete; some employ metal panels, plaster, brick, and/or curtain wall systems. New buildings should creatively use façade materials to produce visual interest and consistency throughout the campus while providing variety

from building to building. The existing palette of materials can be augmented to create visual interest. Proposed new building material and color choices should harmonize with existing campus palettes. Foreground buildings may employ materials and colors that create a distinct identity and distinguish them from other buildings on campus, as is appropriate for their functions.

In conjunction with these highlighted guidelines set forth in the 2003 MDP, this Physical Master Plan document introduces frameworks that act as major drivers for campus organization and development. These frameworks are identified as ‘Green Loop’, ‘Axes’, ‘Height & Density’, ‘Ground Floor Activation’, and ‘Campus Circulation’. These frameworks and the design guidelines supporting them are described further in the following sections.

Design guidelines are intended to guide decisions for future development and are not meant to be restrictive or constraining for the University planning committees or design professionals hired to execute future projects.

Figure 31. Campus Design Guidelines Frameworks





## CAMPUS DESIGN FRAMEWORK: GREEN LOOP

Drawing on the historic campus loop road, the Green Loop provides deliberate and thoughtful connection and organization around and through each part of the campus. These connections are activated by the path of the loop itself – with zones for walking, running, skating, scooting and biking – and by inserting programmatic learning opportunities along the path, which will provide visual orientation and a sense of identity within each campus zone. Identity will be reinforced through the landscaping, vistas and/or artwork associated with nearby academic functions, and by how buildings connect to the Green Loop. The Green Loop will be distinct from other campus circulation by its width, route, organization, type of planting, and relationship to adjacent buildings and open spaces.

Major campus components such as the Arboretum, and new developments such as student housing, the Event Center and other academic buildings will be treated as ‘pearls’ of the ‘necklace’ of the loop. Attachments to the necklace will be defined by landscape components as well as by architectural moves including building ‘front porches’, and by circulation paths being visible and directly adjacent to the Green Loop. The Green Loop is also seen as a recreational opportunity in and of itself and can provide opportunities for more leisurely cross-campus travel.

Figure 32. Green Loop



1. Bow Riverwalk, Alverta (Left)
2. UC San Diego Library Walk (Right)

Figure 33. Green Loop Section: Built Form Context

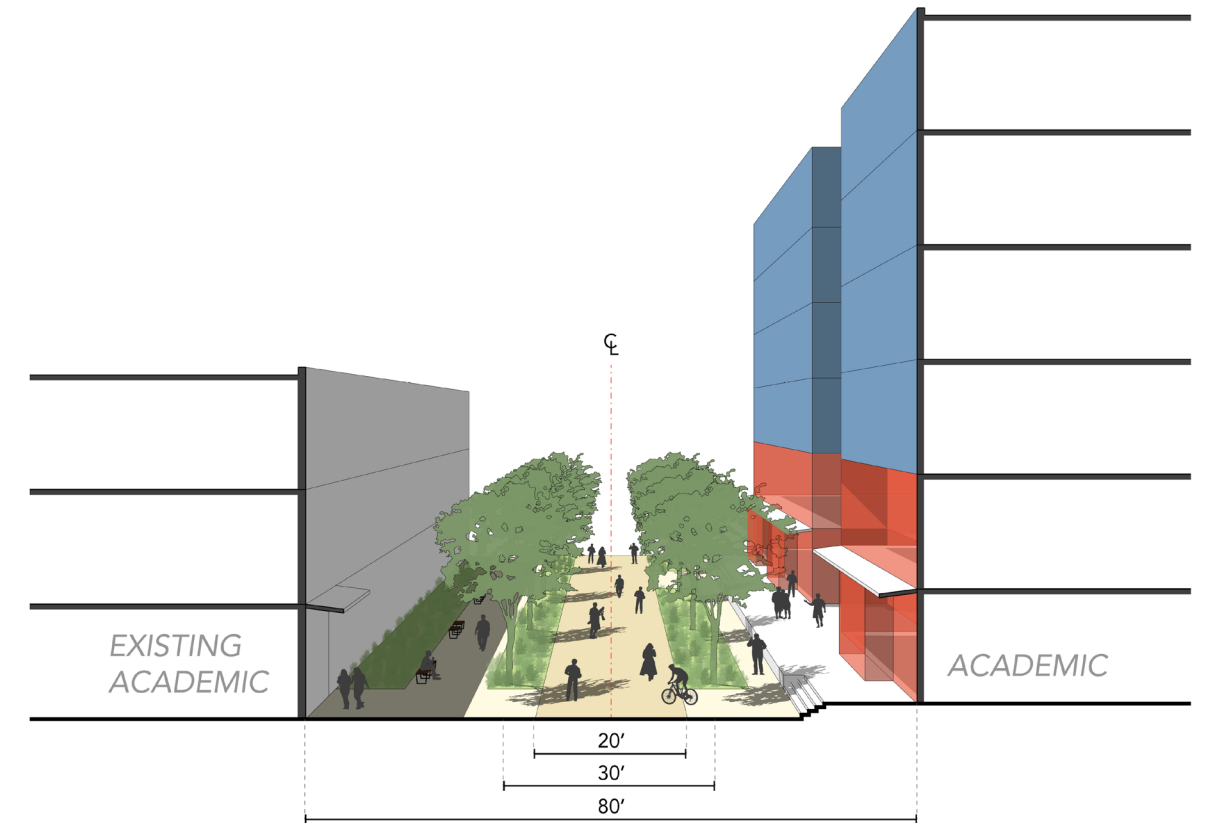
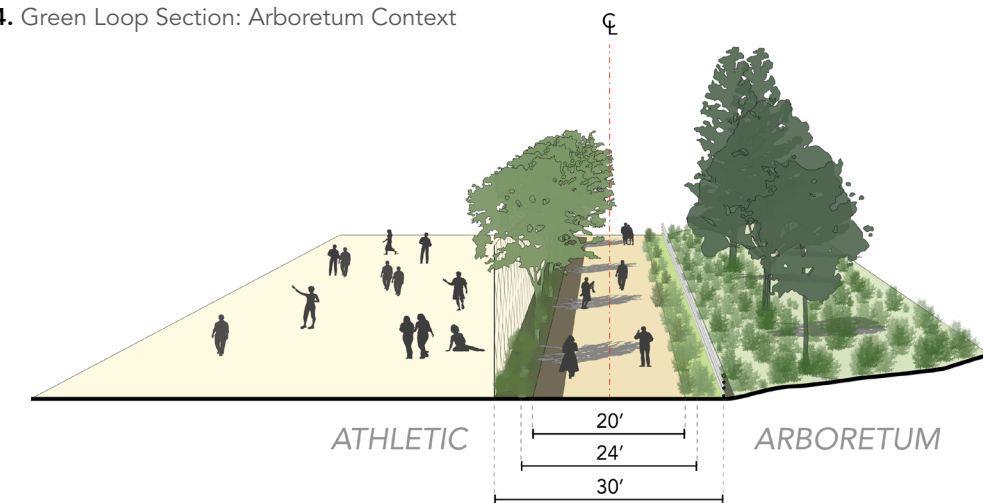


Figure 34. Green Loop Section: Arboretum Context



The multi-modal path will be **20 feet wide** to accommodate separate zones for different speeds of travel from walking to biking and will exclude motor-operated transportation. Rows of trees and planting will occur at a **15-foot setback** from the centerline of the path. Where the path runs adjacent to new open spaces or athletic fields, these rows of trees and plantings will act as a

boundary. Where the path is adjacent to larger existing green spaces or the Arboretum, the setback can occur without the line of trees. When the path passes between existing and planned structures, those buildings will be **set back 40 feet from the centerline of the path.**



## CAMPUS DESIGN FRAMEWORK: AXES

Axes are cross-campus circulation paths that are more linear and cut across and beyond the Green Loop. Axes provide several clear north-south and east-west connections and two diagonal pathways. Axes engage with the Green Loop at node points. These paths offer more direct access to various campus zones, and paired with the Green Loop, contribute to a network of walkable and bikeable access routes throughout the campus.

Key considerations to follow:

- Unobstructed views along axes should be maintained to improve the legibility of the campus
- Edges should be well defined through the built form or through planting
- All axes should be well lit with pedestrian-scaled lighting
- Paving materials should be used to help designate the difference between secondary and tertiary axes

1. Good Line, Sydney (Left)
2. University of Connecticut (Right)

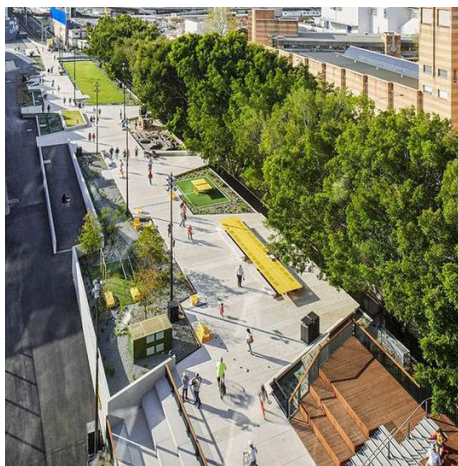


Figure 35. Axes

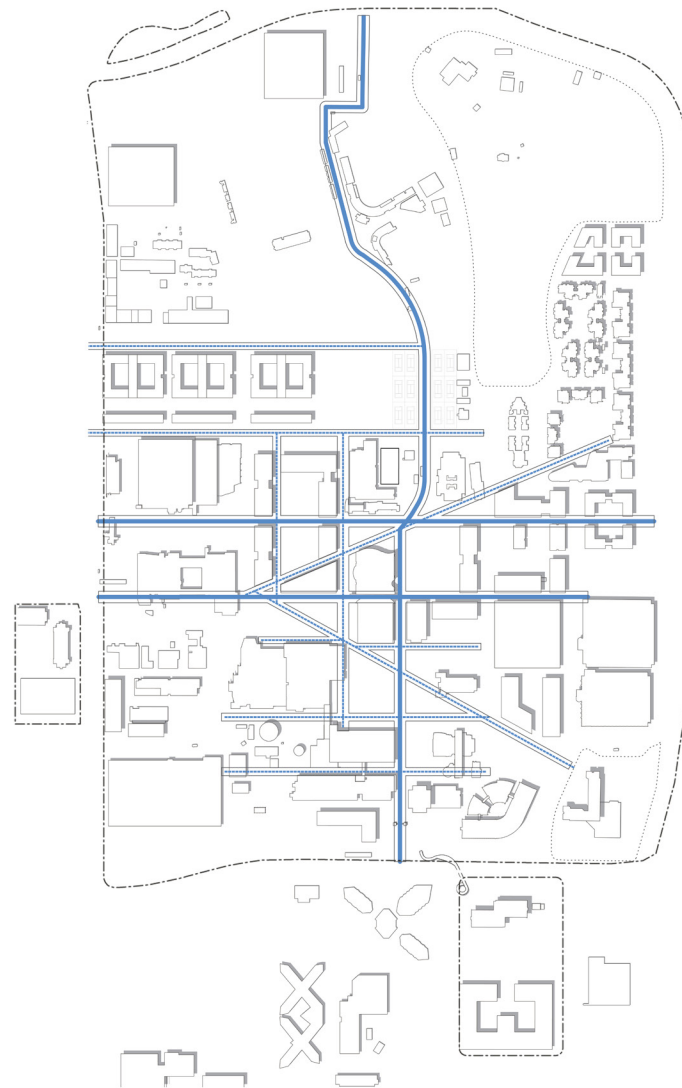


Figure 36. Primary Axes along Longer Side of Buildings

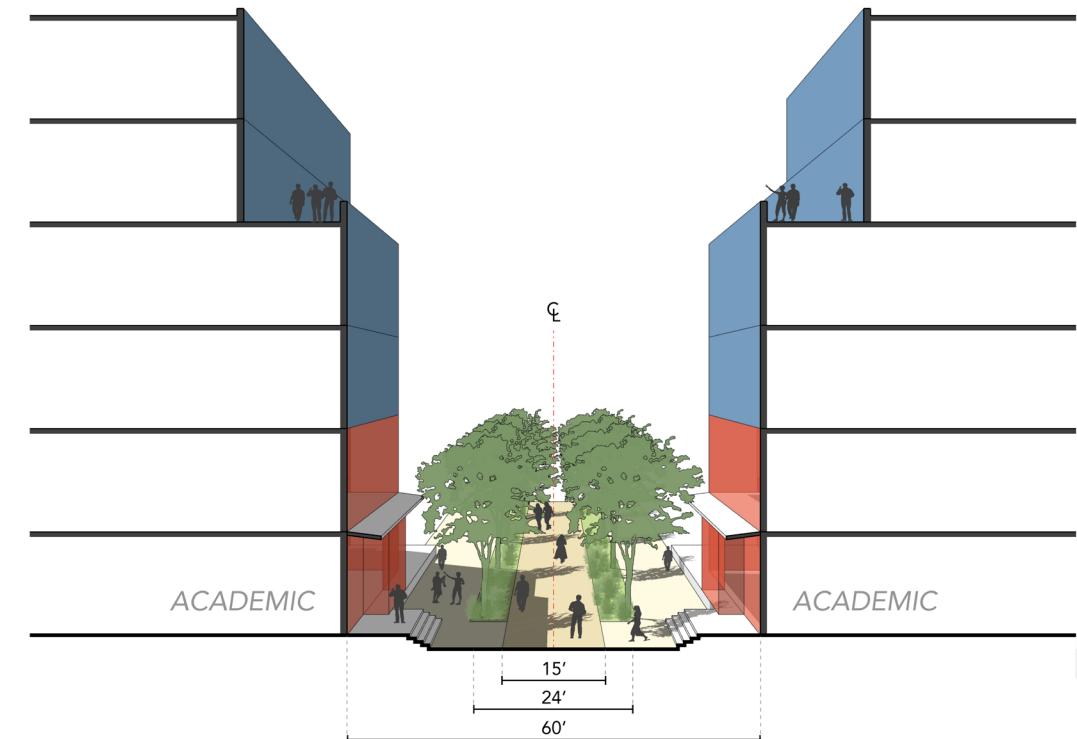
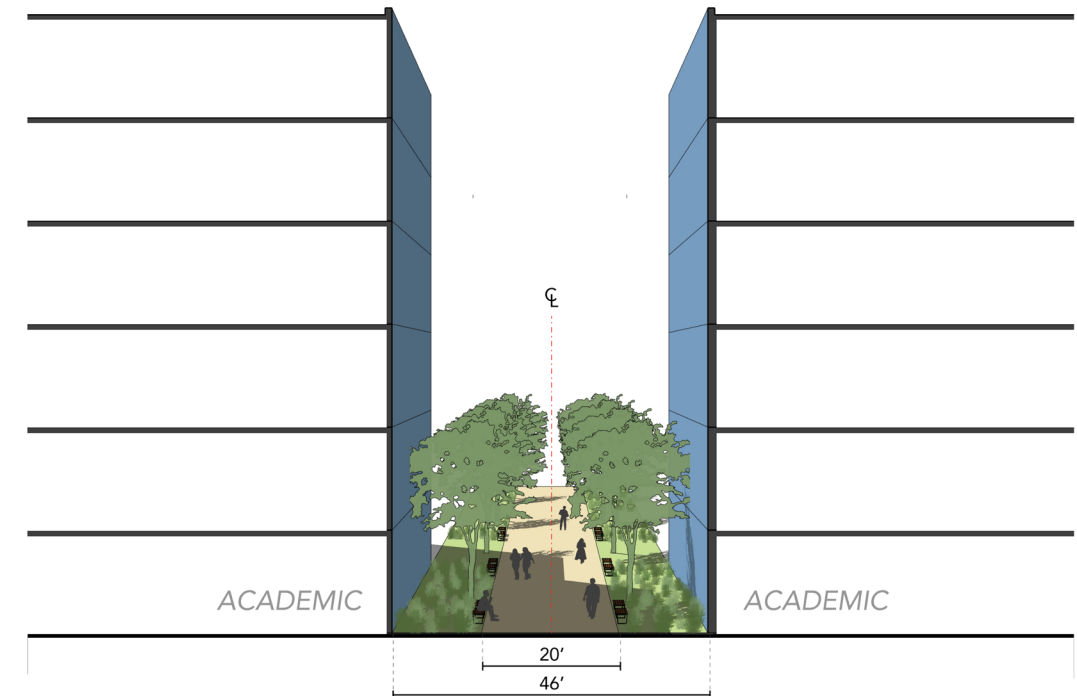


Figure 37. Secondary Axes along Shorter Side of Buildings



The axes network are either primary or secondary. The secondary axes run north south or east west and have a total cross section of **60' from building face to building face**. The tertiary axes are narrower, with a total of **46' from building face to building face**. The tertiary routes provide more lane-way or paseo type connections across campus.

The paths themselves are either **15' or 20' wide** depending on the adjacent structures, with building setbacks either **20' or 30' off the centerline of the path**. Plantings and trees occur **12' or 15' from the centerline of the path**. See the accompanying diagrams.

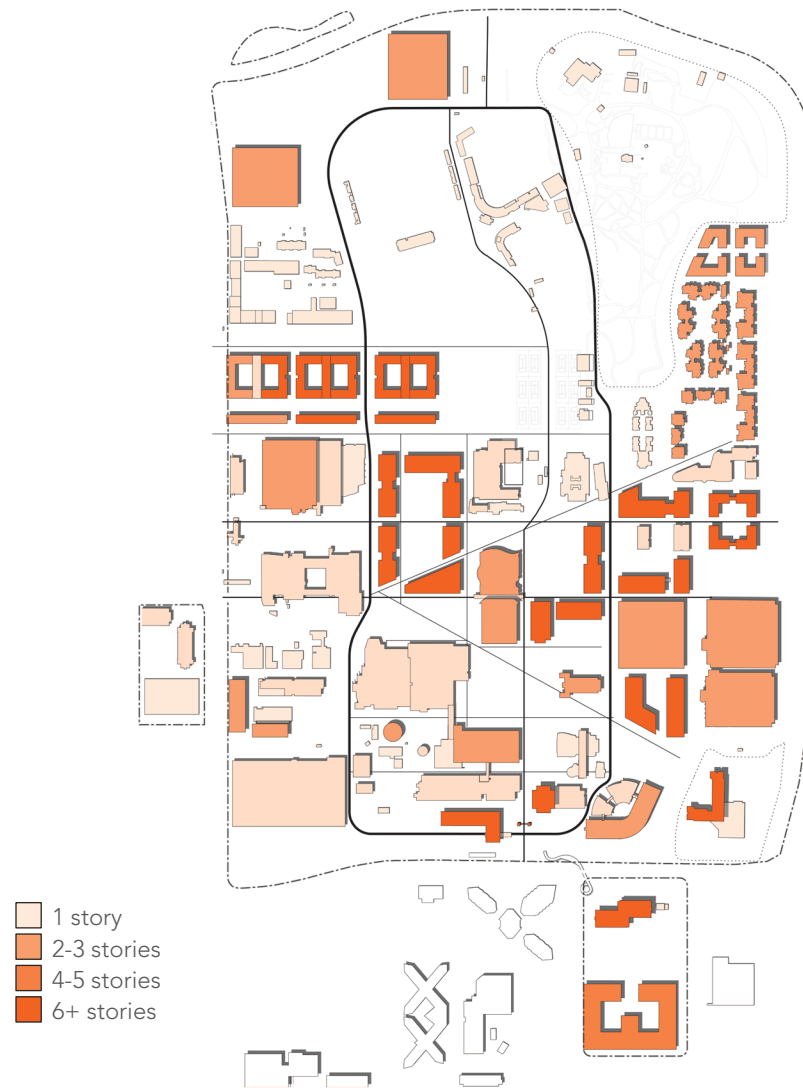


## CAMPUS DESIGN FRAMEWORK: HEIGHT AND DENSITY

The need to accommodate enrollment growth and increased demands on academic space while maintaining open space and a livable and functional campus has presented the opportunity to revisit mass and density on the campus. Considering the highest and best use for campus land has resulted in planning for growth to include new buildings up to six or seven stories in height.

There are a number of taller historic buildings on the campus that were part of the original build-out including McCarthy Hall and Pollak Library, which act as precedents for this scale for academic buildings. The departure from the status quo for the campus is the attitude about residential buildings, which have historically been much smaller in scale. Providing student on-campus housing is one of the most impactful initiatives to support the University's mission. The Physical Master Plan proposes higher, more densely populated residential buildings while augmenting and maintaining ample open space.

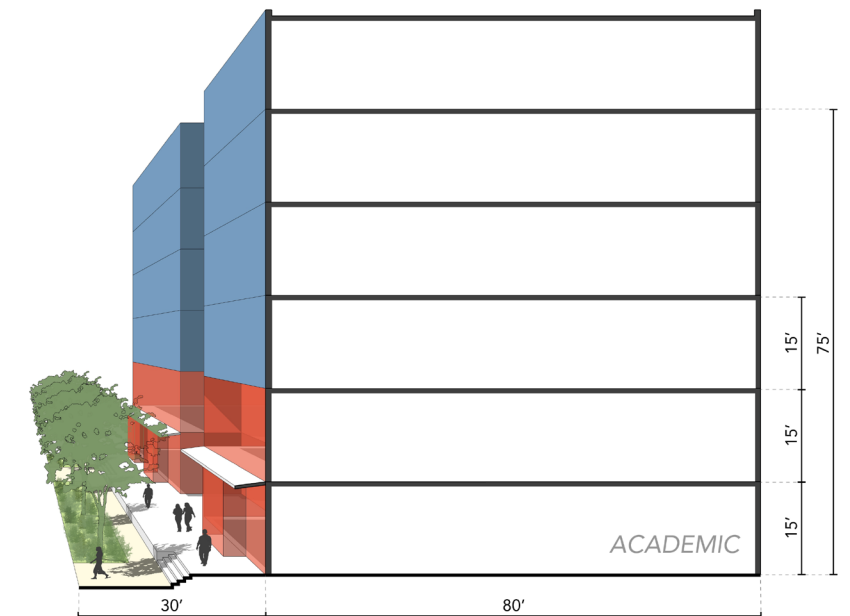
Figure 38. Building Heights across Campus



### Academic Buildings:

- Up to 6 stories or 75 feet from the ground level to the top floor level
- Ground floor 15 feet floor-to-floor, upper floors also 15 feet floor-to-floor
- Floor-to-floor height provides opportunity for increased depth of daylight penetration

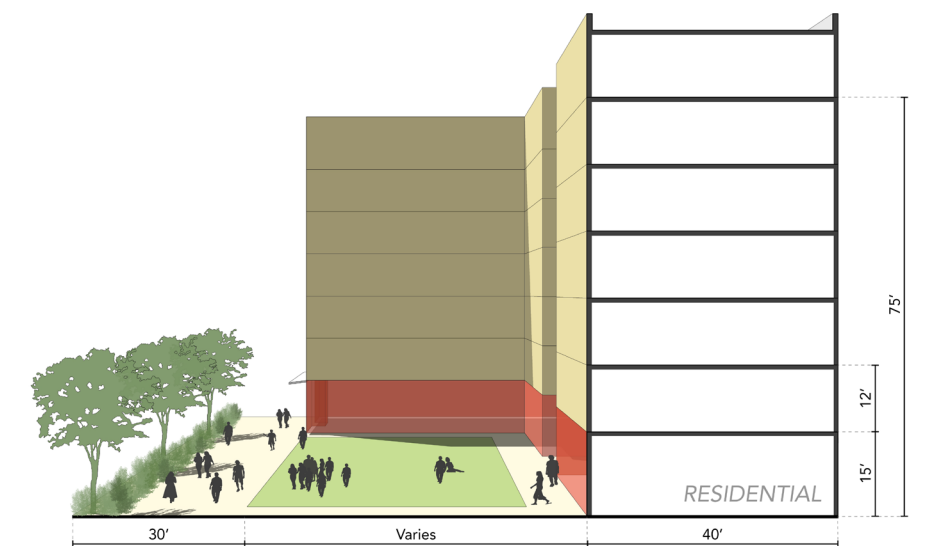
Figure 39. Typical Academic Building Height and Massing



### Residential Buildings:

- Up to 7 stories or 75 feet from the ground level to the top floor level
- Ground floor 15 feet floor-to-floor, upper floors 12 feet floor-to-floor
- Floor-to-floor height contributes to effective daylight penetration in occupied spaces

Figure 40. Typical Residential Building Height and Massing



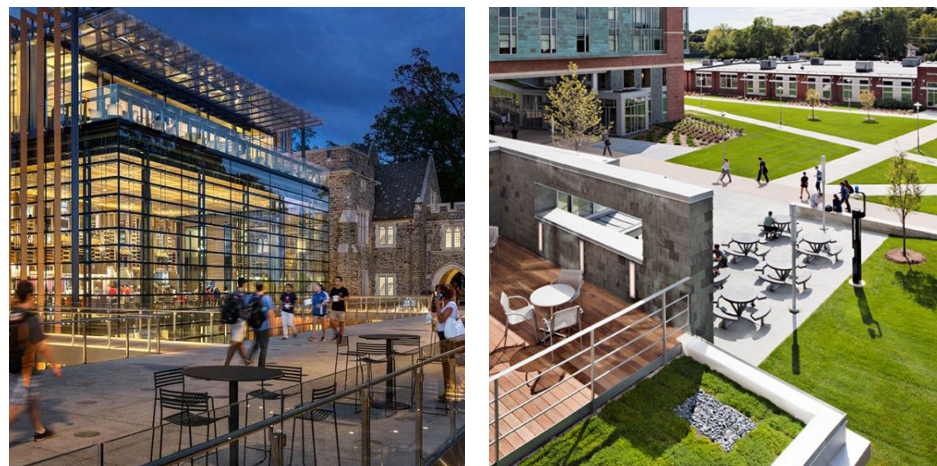
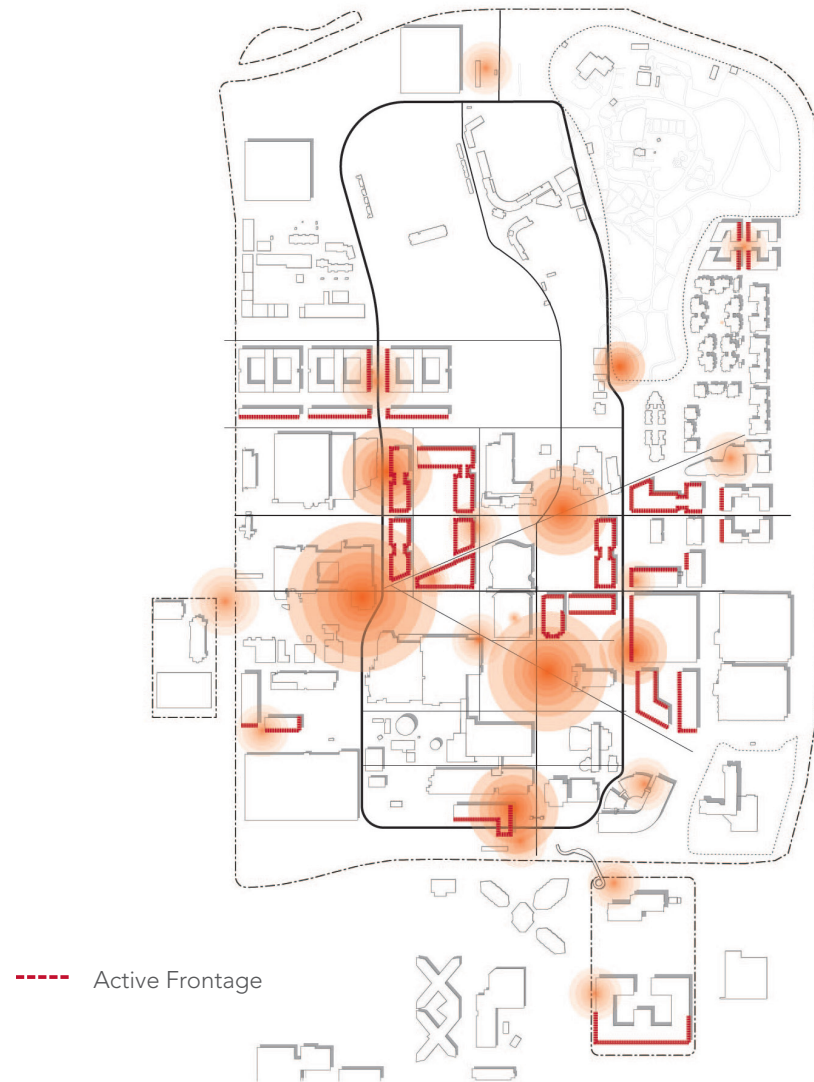
There are practical reasons to limit the height of buildings to 75 feet. Buildings that have a top floor above 75 feet from the ground level are classified as high-rise buildings and subject to stricter building code provisions, adding significant cost. This regulatory parameter coupled with the determination of the appropriateness of these heights relative to the scale of the campus, are drivers for guiding density and height.



## CAMPUS DESIGN FRAMEWORK: GROUND FLOOR ACTIVATION AND BUILDING FOOTPRINTS

Being able to readily identify building functions and internal activities helps to orient the campus user, and creates a clear and safe path and sense of arrival at each destination. This should be achieved by programming student-life functions at ground levels and by designing for transparency at the ground floor, creating “front porches” at each building. Entrances should be oriented toward and visible from circulation paths and should be well-lit, inviting spaces that are programmed for group study or socializing. They may provide café functions or other opportunities for students and others to congregate. The architecture of the façade at these spaces should connect people to the outdoor environment and allow for appropriate daylight penetration and views into the building. Other components of entrances, front porches and ground-floor design should reflect the functions occurring in the rest of the building. This could be achieved by creative design of the interior spaces, through graphics or artwork or other means. Activation of ground-floors must also be considered for any renovations or building re-purposing. Providing transparency and activating the ground floor in this manner creates a sense of identity at various locations, offers ample and varied opportunity for informal learning and adds a level of vibrancy and excitement across the campus.

**Figure 41.** Ground Floor Activation and Building Footprints Framework

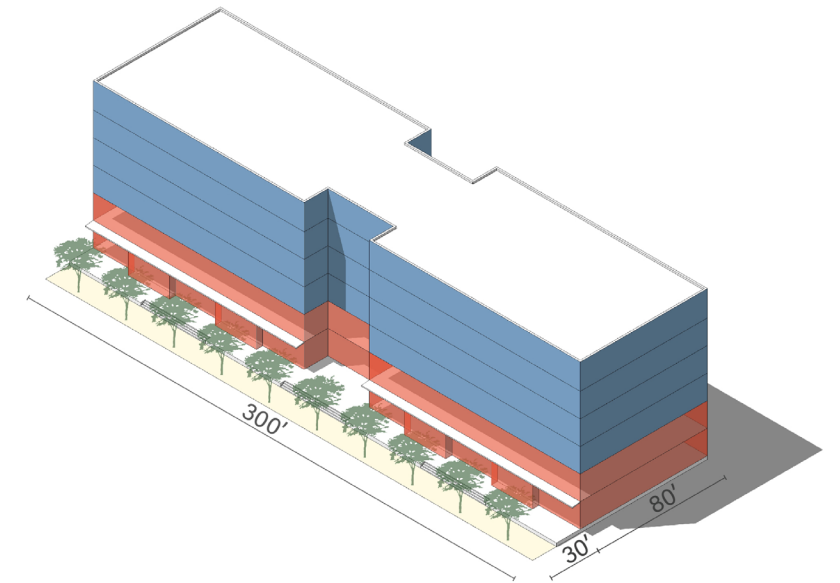


1. Duke University (Left)
2. Mount Summit Stone University (Right)

**Figure 42.** Typical Academic Building Ground Plane Activation and Footprint

### Academic Buildings:

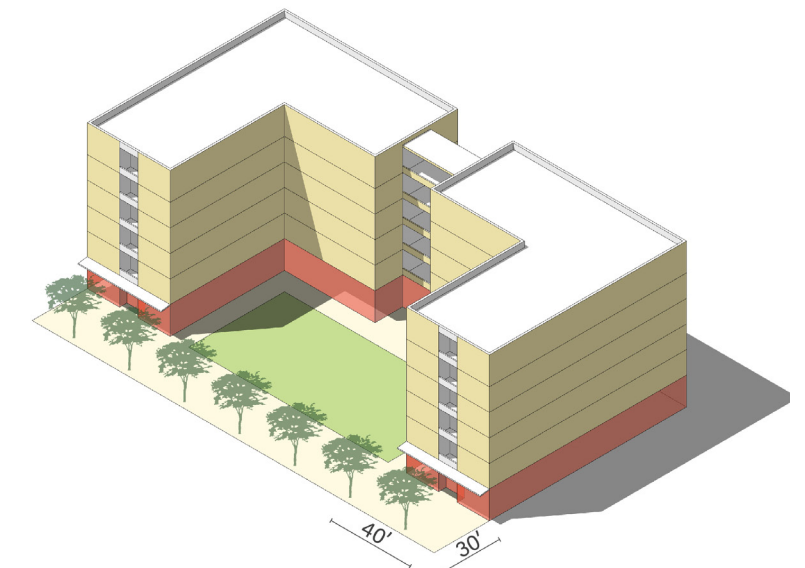
- Student-life program is integrated into each building planning program, with special focus on the ground floor
- Student-life program areas should have visual transparency to adjacent spaces and the outdoors
- Plan with wide central corridors with classrooms and/or labs on either side and allowing for generous space within the floor plate for informal learning places
- Building width balances floor plan programming and opportunities for increased depth of daylight penetration
- 80-90 feet wide



**Figure 43.** Typical Residential Building Ground Plane Activation and Footprint

### Residential Buildings:

- Student-life program is integrated into each building planning program, with special focus on ground floors
- Student-life program areas should have visual transparency to adjacent spaces and the outdoors
- Plan for double-loaded corridors with dorm rooms on either side
- Depth of building footprint allows for efficient dorm layout and daylight penetration in occupied spaces
- 40-45 feet wide





## CAMPUS CIRCULATION

In the campus core, walking is the primary mode, with scooters, skate boards, and campus carts permissible. Biking, while not explicitly designed for in the inner core is permitted with the exception of dismount zones (outlined in the mobility section). Limited auto access is permitted for emergency vehicles and services. The Arboretum's access is primarily walking as well.

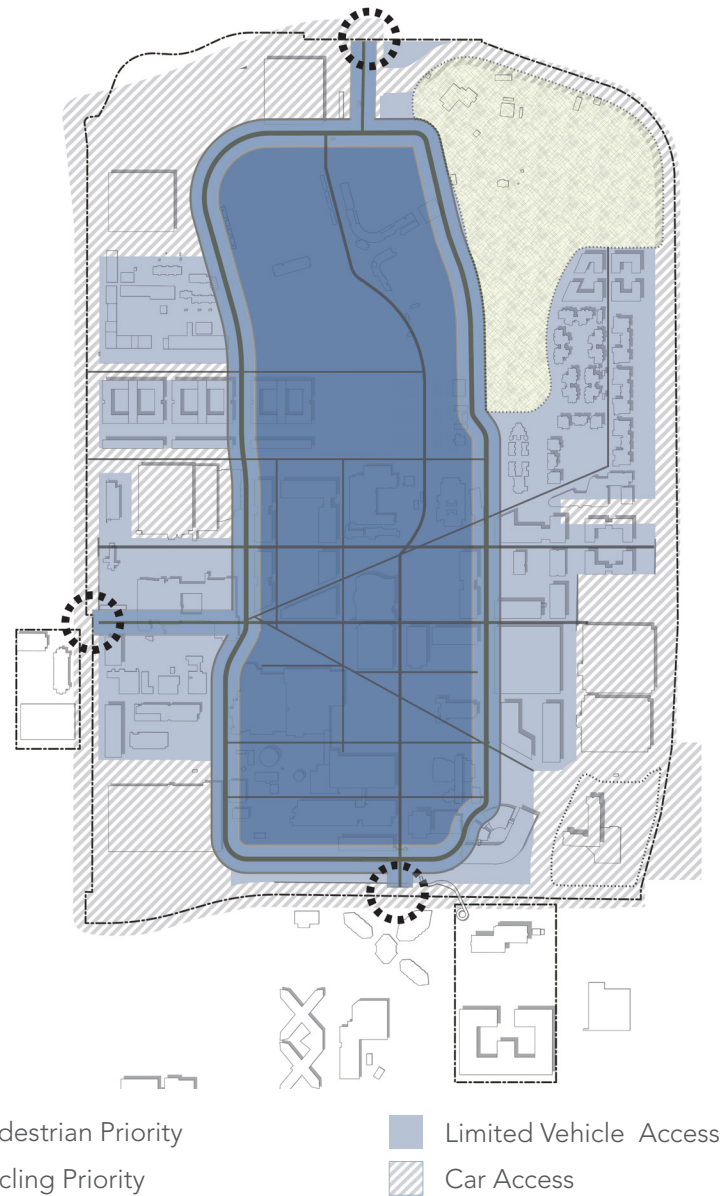
The Green Loop acts a key recreation and practical part of the walking and cycling network on campus. Bicycle facilities are provided along these routes, paths provide sufficient width to accommodate both cyclists and pedestrians.

Vehicle access (along with all other modes) is permitted around the perimeter of campus. All parking is located in this outermost area, with only minimal access to more inner parts of campus. Areas on campus that permit cars should still treat autos as guests. Streets should be easy to cross as a pedestrian and vehicles should be slowed by introducing friction and narrowing lanes.

Other components of the campus circulation strategy include perimeter circulation and connection points to the surrounding community. Perimeter points are thresholds to the campus where many will enter campus and transition from buses, cars, bikes or skateboards and continue to the core of campus on foot. These points are characterized as mobility hubs or as pedestrian links to internal campus circulation paths.

For design guidance on internal paths, refer to the Green Loop and Axes design guidelines. For service

Figure 44. Campus Circulation Framework



roads and other internal roads, refer to figures 123 and 124. A 10-foot-wide travel lane is narrow enough to satisfy the needs of many private vehicles. Eleven feet for larger vehicles, seven feet for separated bike lanes, and not less than nine feet for sidewalks should be provided.

Figure 45. Automobile and Bicycle Internal Street

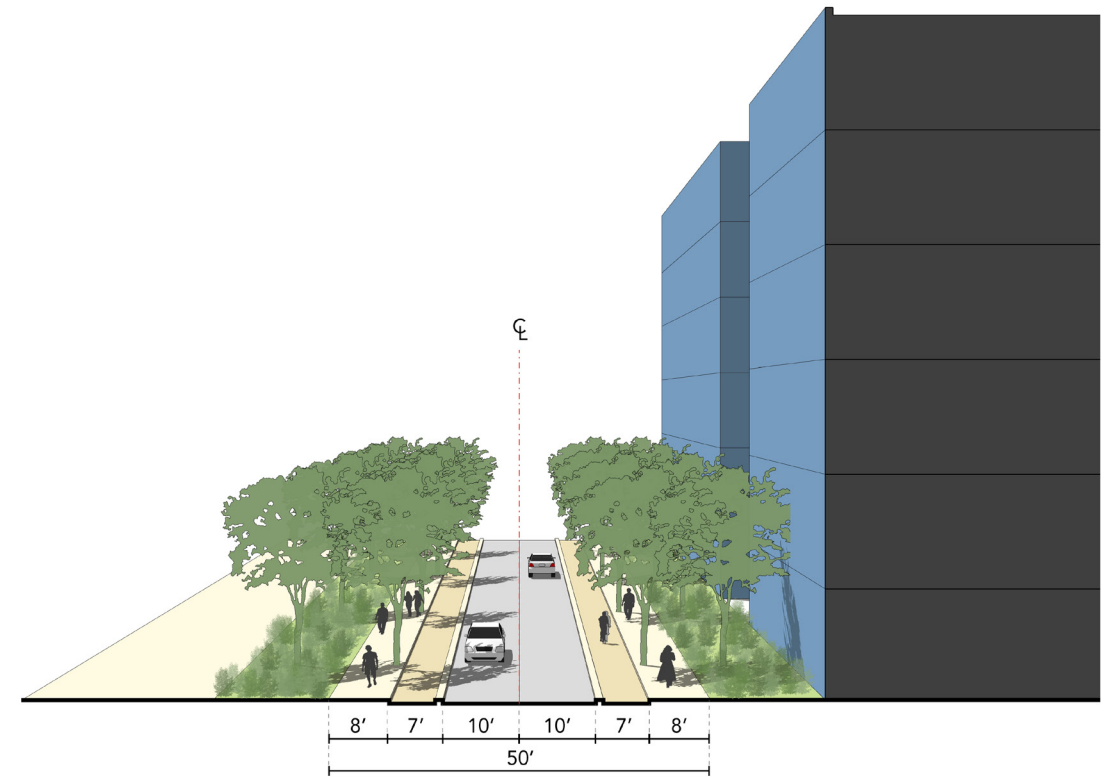
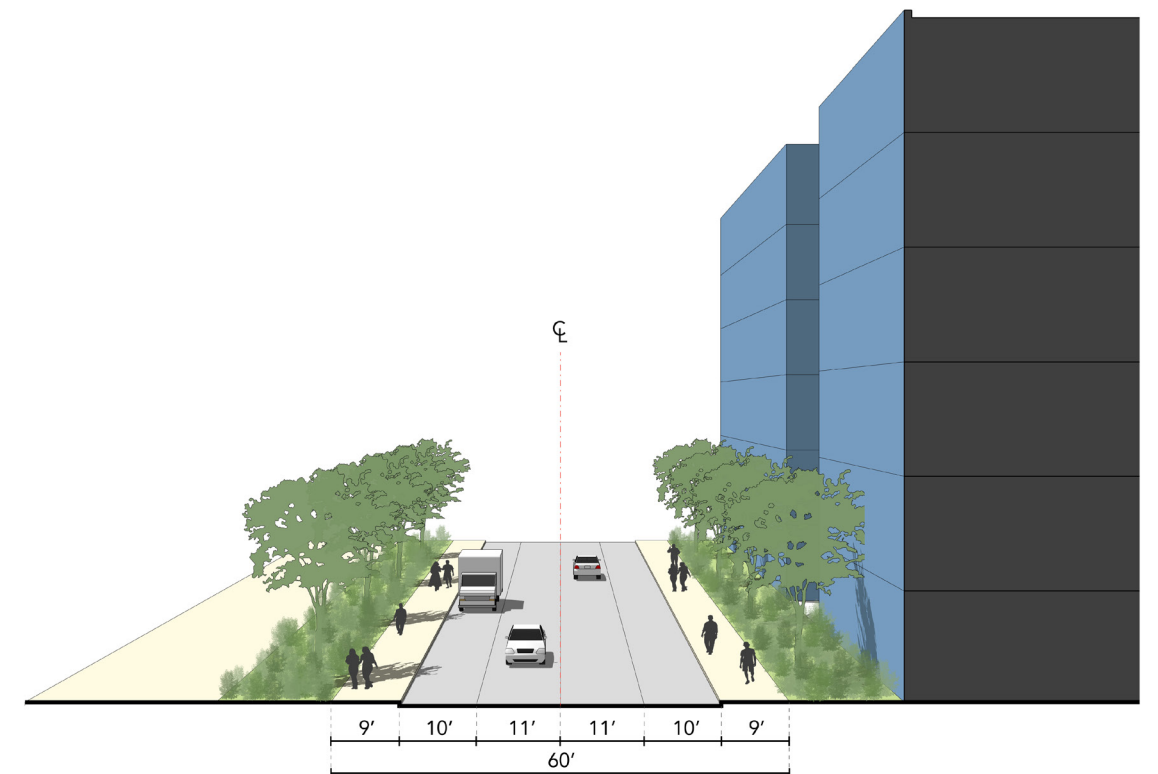


Figure 46. Typical Internal Street- Delivery Vehicle/Larger Vehicle







# Campus Built Form

Originally known as Orange County State College, Cal State Fullerton was founded in 1957 on a site of former citrus groves. Several structures that date to the late 19th and early 20th centuries and prior to the University's founding exist on the campus today. Of historical significance from this period include the Titan House, Golleher Alumni House, and the Heritage House. Currently located in the Arboretum, the Heritage House is listed on the National Register of Historic Places.

Cal State Fullerton has a rich architectural history related to its academic buildings as well. Approximately 40 percent of the campus' current building stock was constructed during the heyday of New Formalism, Brutalism, and Late Modernism between 1960 and 1974.

Because this development occurred in a relatively short period of time, Cal State Fullerton's campus exhibits several distinctive representations of the New Formalism style in particular, and the collection of these structures

and the landscape and hardscape that surrounds them created a unique and unified architectural character and style across the campus. The earliest grouping of buildings comprise the Historic Campus Core and include McCarthy Hall, Claves Performing Arts Center, Pollak Library, the Humanities and Social Sciences Building, and Langsdorf Hall.

The campus has continued to expand over the years and recent additions include Mihaylo Hall and the Titan Student Union, among others. Future additions to the built environment should strive to create cohesion with the existing campus buildings while meeting program needs. Built-form goals for the campus include creating a vibrant, active and livable campus whose buildings provide formal and informal learning spaces, support a 24/7 campus, and connect to green and open spaces. The following pages describe the Physical Master Plan build-out.

---

## CAMPUS BUILT FORM GOAL

To create a vibrant, active and livable campus where people want to be to learn and grow.

---



# MASTER PLAN BUILD-OUT

- 1 Academic 1: 125,000 sq ft
- 2 Academic 2: 132,000 sq ft
- 3 Academic 3: 50,000 sq ft
- 4 Student Life 4: 150,000 sq ft
- 5 Academic 5: 240,000 sq ft
- 6 Academic 6: 108,000 sq ft
- 7 Academic 7: 54,000 sq ft
- 8 Innovation Center: 72,762 sq ft
- 9 Academic 9: 84,000 sq ft
- 10 Academic 10: 180,000 sq ft
- 11 Academic 11: 85,000 sq ft
- 12 Academic 12: 55,000 sq ft
- 13 Academic 13: 52,528 sq ft
- 14 Academic 14: 120,000 sq ft
- 15 Academic 15: 120,000 sq ft
- 16 Academic 16: 126,000 sq ft
- 17 Event Center: 254,100 sq ft
- 18 Student Housing 1 (proposed prior to Master Plan): 203,000 sq ft
- 19 Student Housing 2: 803,880 sq ft
- 20 Student Housing 3 (Replacement): 185,420 sq ft
- 21 Faculty Housing: 540,000 sq ft
- M Mobility Hub
- P Parking Garage

Figure 47. Physical Master Plan Build-out



### Existing Land Uses

- Student Housing
- Academic
- Parking
- Arts and Culture
- Facilities

### Proposed Land Uses

- Student Housing
- Academic
- Campus Amenities
- Parking
- Arts and Culture
- Innovation Center
- Mobility Hubs
- Facilities

**Total New Construction of 5,000,000 GSF**



# MASTER PLAN 2025 AND MASTER PLAN 2039

The Physical Master Plan 2039 encapsulates all projects that are not existing. However, several projects have either already been approved, are pending construction, or have already been addressed in previous EIR evaluations from the previous master plan. The following proposed buildings have already been approved for construction and their environmental impacts have been assessed:

- 1 Corporation Yard
- 2 Sports Complex Additions
- 3 Eastern Parking Structure 2
- 4 Student Housing Phase 4
- 5 Visual Arts Center Replacement

**Figure 48.** Master Plan 2025 and Master Plan 2039 Proposed Projects



Existing Today (2020)

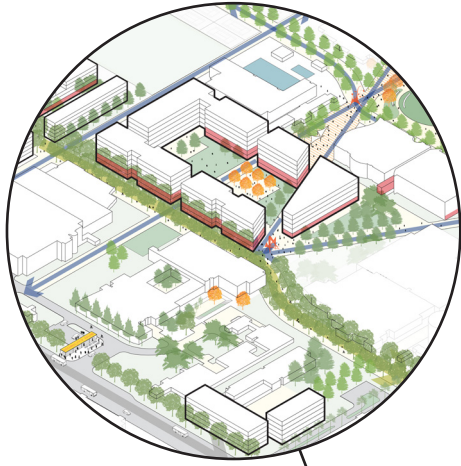
Unbuilt projects approved from previous Physical Master Plan's 2003 EIR

Proposed Physical Master Plan 2039 build out and basis for current EIR

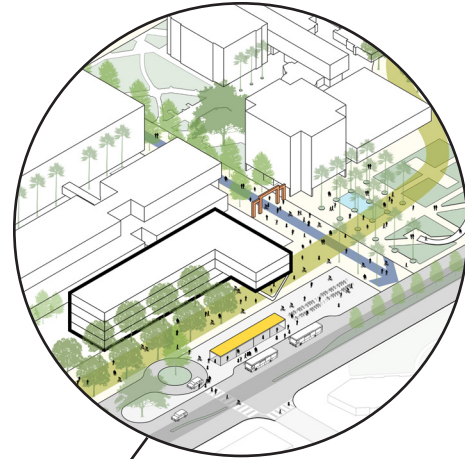


Figure 49. Districts across Campus

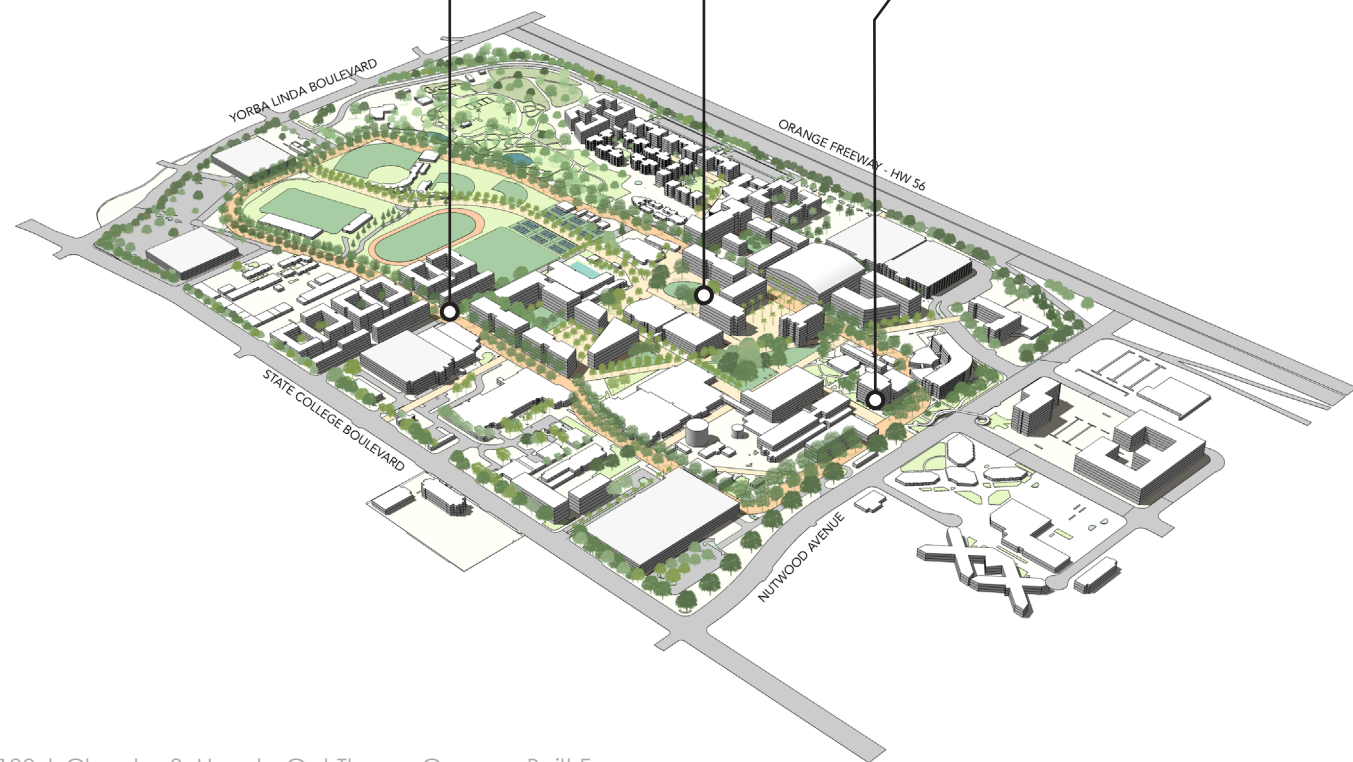
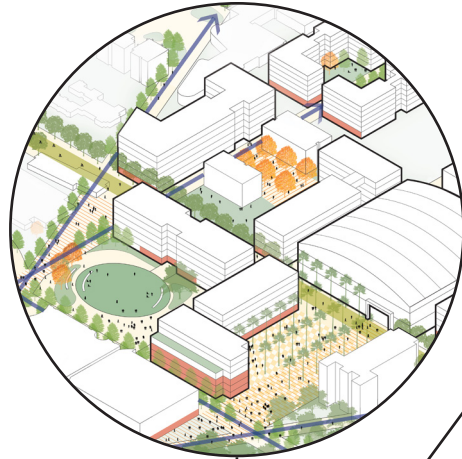
**Residential and Student Life**



**Mobility Hub and Main Entrance**



**Events and Innovation**



## DISTRICTS

Much like a city is comprised of neighborhoods, campuses can be divided into smaller districts. To create a campus that attracts people across the day and week, the Physical Master Plan seeks to apply urban design techniques that support functioning districts. The Physical Master Plan establishes three districts and organizes campus access features: Events and Innovation District, Mobility Hub and Entrance District, and Residential and Student Life District.

By designing at the district scale, one is more likely to create interest, activity, and identity across the entirety of campus. These districts will become areas where someone can get a great deal of what they need on a day-to-day basis (classroom, coffee, food, and basic supplies) with only a short walk. Each district has an additional component that is an attractor, concentrating events, housing, or mobility.

Districts can also help to illustrate the importance of each component of the plan in realizing the vision for the campus. In the following pages, key design features have been highlighted by through the vision icons.



Values



Identity



Learning



Connection



Activation



## EVENTS AND INNOVATION DISTRICT

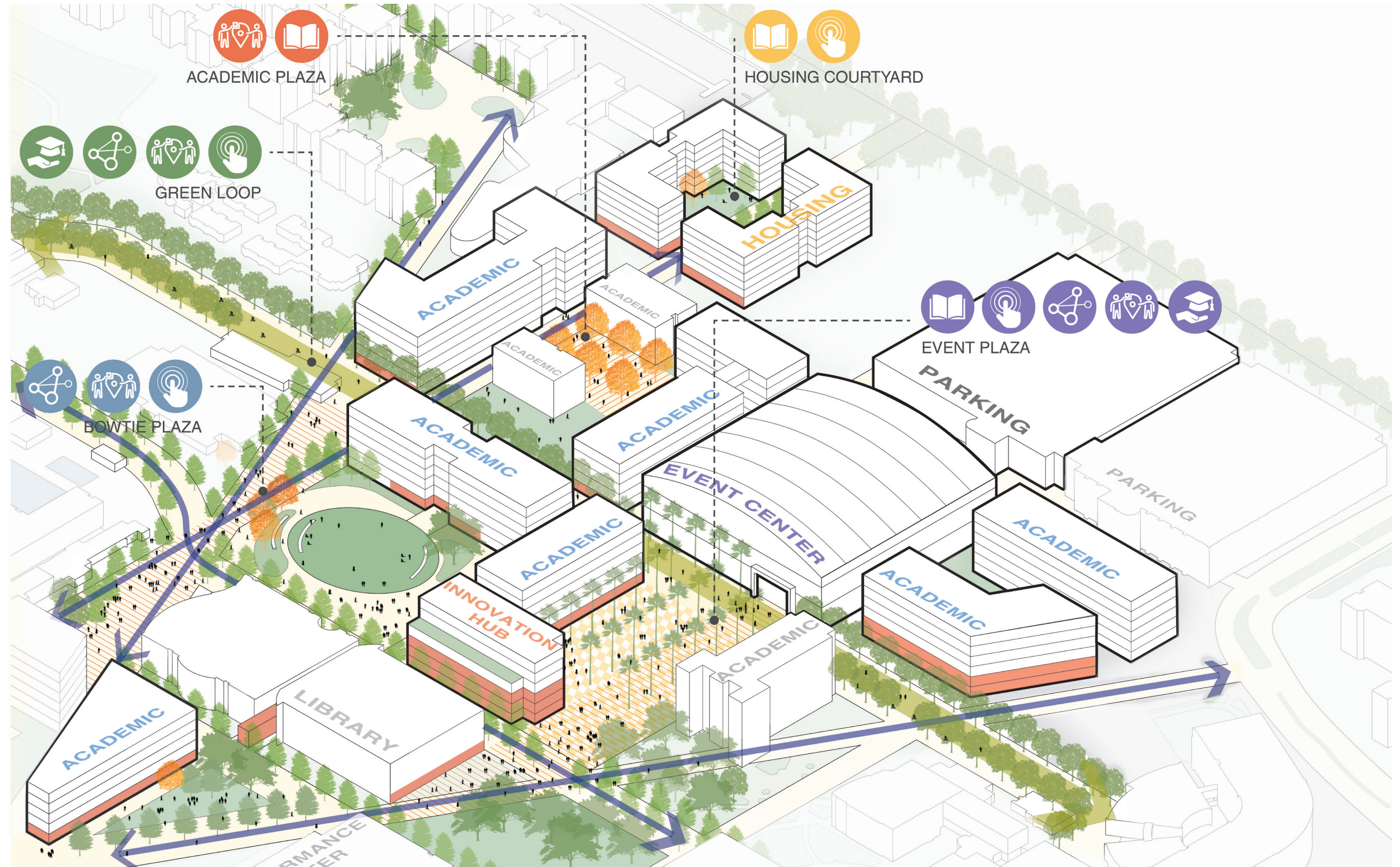


The Events and Innovation District concentrates two new uses (the Event Center and Innovation Hub) in an area of campus that is currently either surface parking, low density buildings, or open space without clear definition. This area will become the counterpart of the student center, drawing students from other parts of the campus. Academic uses are surrounded by other destinations, with the Arboretum just to the north and athletic facilities in the new Event Center.

### Recommendations

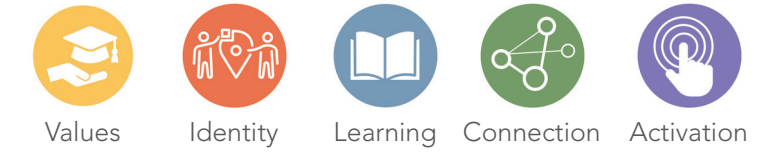
- Café in the events plaza on the ground floor.
- Keep clear connections to the Performance Center from the Event Center and Innovation Hub.
- Use art at strategic nodes (near bow-tie plaza and on the main north south axis to denote key locations).
- Maintain a green/lawn just south of bow-tie plaza to provide the main green space area for this district.
- A retail space should be included within the Innovation Hub.
- Clear connections to housing, with alternative routes on top of the main axes.
- Trees establish more formalized corridors.
- The Event Center should be used as a hub for both events and resiliency. It is a natural choice for emergency shelter and during its design, should consider the use of that function.

Figure 50. Events and Innovation District Diagram





## RESIDENTIAL AND STUDENT LIFE DISTRICT

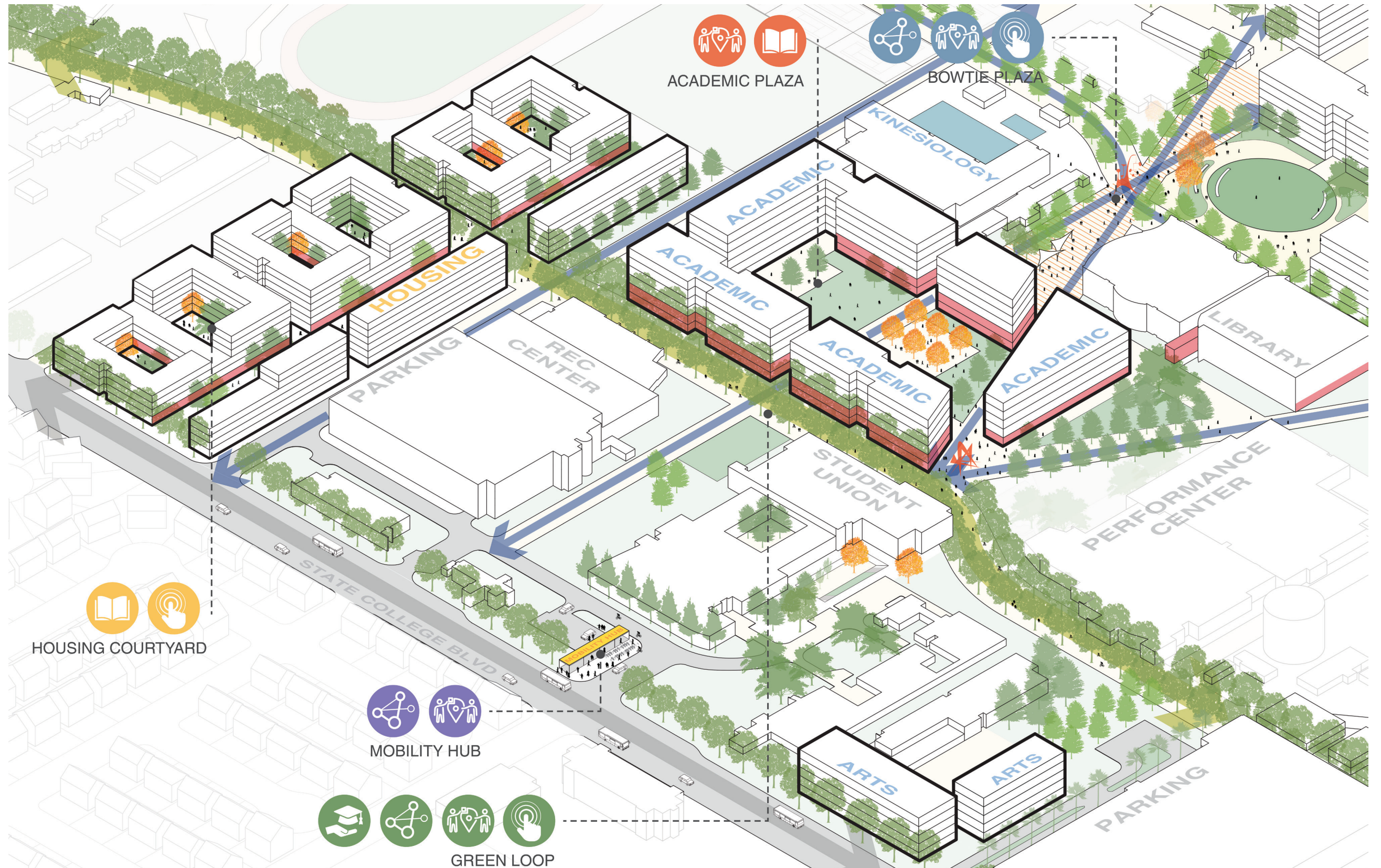


The residential and student life district is a concentration of student housing, the most that has ever been proposed on the campus, and the existing student union nearby. While academic uses are located throughout campus, including in this district, this area will become a destination and home for many students. One of the buildings in this area will be entirely dedicated to student amenity as well, creating a home for student life beyond academics. Therefore, the district should respond accordingly, with design features that reflect the residential features.

### Recommendations

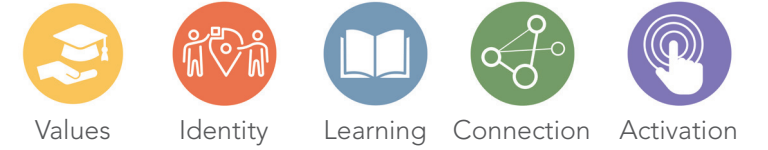
- Keep clear connections from Housing to the student union, include routes in addition to major access via the Green Loop.
- Courtyards in this district should reflect the adjacent uses and provide a semi-private public realm for students, faculty, and staff.
- The new amenity building should be considered as a possible resiliency hub for the district, if it cannot be accommodated by the Titan Student Union. The current functions of the Student Union should remain.
- The green space adjacent to the housing should be landscaped for versatility - allowing for informal recreation and gathering.

Figure 51. Residential and Student Life District Diagram





## MOBILITY HUBS AND MAIN ENTRANCES



By their very nature, entrance points onto campus concentrate people. Coupled with the proposed mobility hubs (to be discussed more thoroughly in the mobility section), people will be passing through these areas of campus multiple times per day. A campus can capitalize on that activation and create places that both establish the identity of campus and also function as enjoyable places to linger and learn.

### Recommendations

- Wayfinding is especially critical in this area of campus as it is a welcoming area and often a person's first introduction to campus. Signage should be used to direct people to destinations further away. For closer destinations, physical cues, such as pavers and other design features should help indicate how to get to destinations and should subtly draw students, faculty, staff, and visitors into the core of campus.
- All main entrances should clearly connect to the Green Loop and a main axis.
- Use art at strategic nodes (near bow-tie plaza and on the main north-south axis) to denote key locations.
- Outdoor seating and wifi areas should be placed throughout this district.
- Café or food access should be located near the main entrance.

Figure 52. Mobility Hub and Main Entrance District Diagram

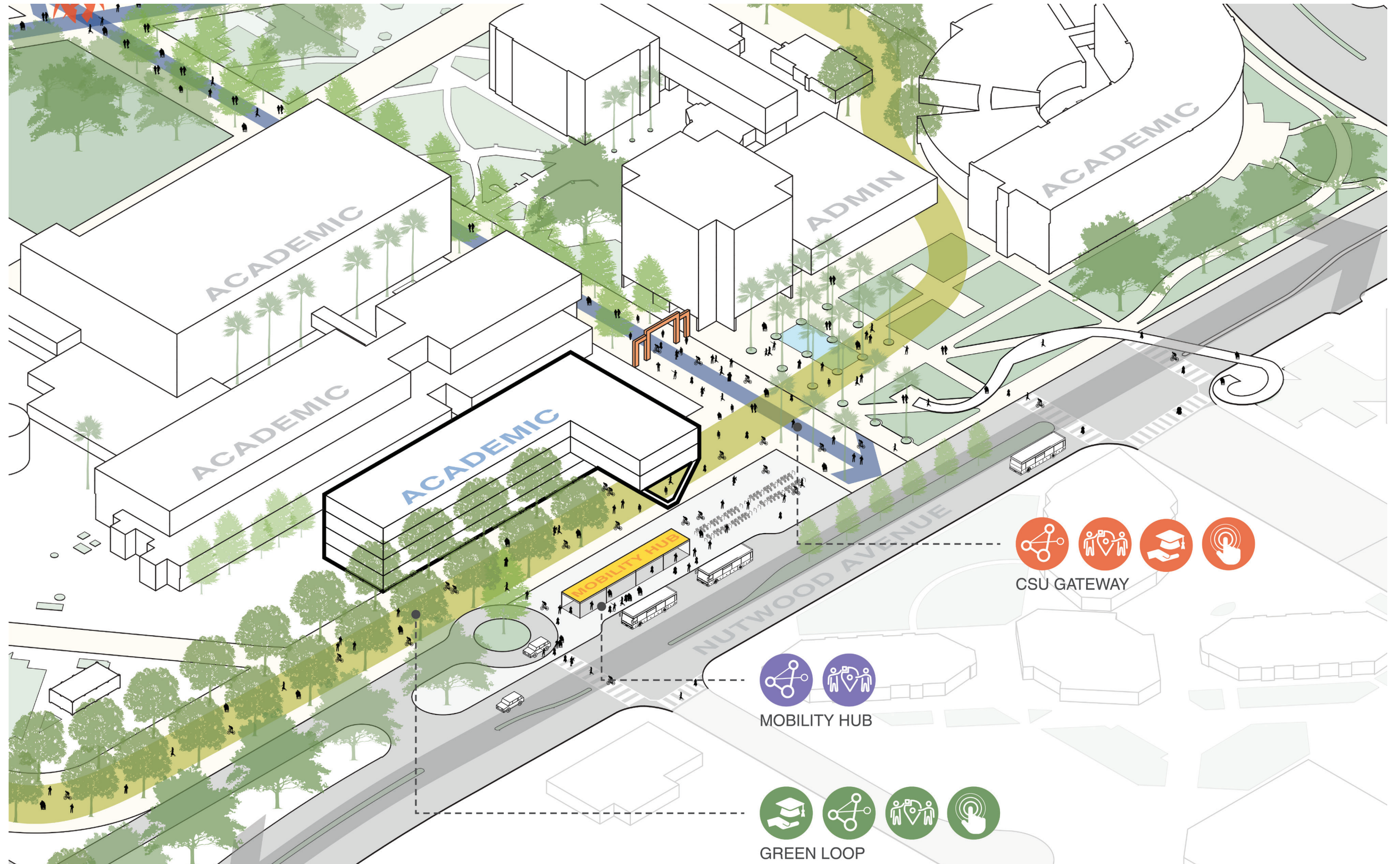




Figure 53. Overall Land Use Plan



## BUILT FORM PROGRAM

The table below denotes the growth of campus derived from academic entitlements and the additional student life infrastructure elements that accompany them. Special initiatives like the Innovation Center, the new Event Center and projected replacement facilities for the Arboretum are also included. Note that existing building efficiencies are low and the tabulation of parking structures also drives the efficiencies down. New space is targeted in the range of 60 percent efficiency, in line with current best practices.

Table 4. Program Summary

Space Type	Notes	GSF	ASF
Existing Facilities	Per Facilities Report (Main Campus only)	6,315,097	2,337,895 <sup>1</sup>
New Student Housing	2,400 new beds including associated amenities (proposed and replacement housing not included)	803,880	522,000
New Campus Amenities	Rec, Union, Wellness, Student Success	800,000	480,000 <sup>2</sup>
New Faculty /Staff Housing	Blend of 1, 2, & 3 bedroom apartments (350 units)	539,000	350,000
New Academic Space	Based on 32,000 FTES	881,526	528,916 <sup>3</sup>
New Non Academic	New Retail	40,000	25,000
New Innovation Center		72,762	40,200 <sup>4</sup>
New Facilities in Arboretum		100,000	60,000 <sup>5</sup>
New Event Center	6,000 seats	254,100	165,000
New Mobility Hubs	Assumes all are exterior (120'x20')	7,200	0
New Parking Structures	Assumes 4,473 supported spaces at 375 sf/space	1,677,375	0
Demo part of KHS	Event Center will replace the gym	-131,732	-79,000
<b>CAMPUS TOTAL</b>		<b>11,359,208</b>	<b>4,430,011</b>
<b>TOTAL NEW CONSTRUCTION</b>		<b>5,044,111</b>	<b>2,092,116</b>

1. Assumes 5,622,862 existing GSF on Main Campus including Corporation Yard and all 'replacement' facilities. Also includes projects under review by Chancellor's Office (600 new beds, baseball facilities, east parking addition, and Visual Arts)
2. Approximately 69 ASF per additional FTES
3. GSF assumes 60% efficiency
4. 55% efficiency
5. 60% efficiency



## HOUSING AND STUDENT LIFE

The Physical Master Plan proposes providing an additional 3,000 student beds, which includes a new 600-bed structure to replace an outdated building to be demolished. The Plan considers three housing clusters, the first of which is the 600-bed replacement facility on the south edge of the existing housing units on the east side of campus.

The second and largest proposed housing cluster creates a new student housing zone on the west side of campus and provides over 1,800 beds.

The implementation of this housing cluster on the west side balances and reflects the established housing cluster on the east side, activating this central part of campus.

The third cluster of student housing providing over 500 additional beds will bookend the northern edge of the currently existing housing units on the east side. All the student housing will generally be located north of Gymnasium Drive, keeping the focus of the south end of campus on academic functions.

A fourth cluster of housing dedicated to faculty and staff is proposed south of Nutwood Avenue. Difficulty finding housing near campus has been identified as one of the challenges that potential faculty and staff face when considering jobs at CSU Fullerton. This cluster will provide opportunities for living near campus and will help with retention and recruitment while maintaining an appropriate separation from student housing clusters.

Figure 54. Student and Faculty Housing

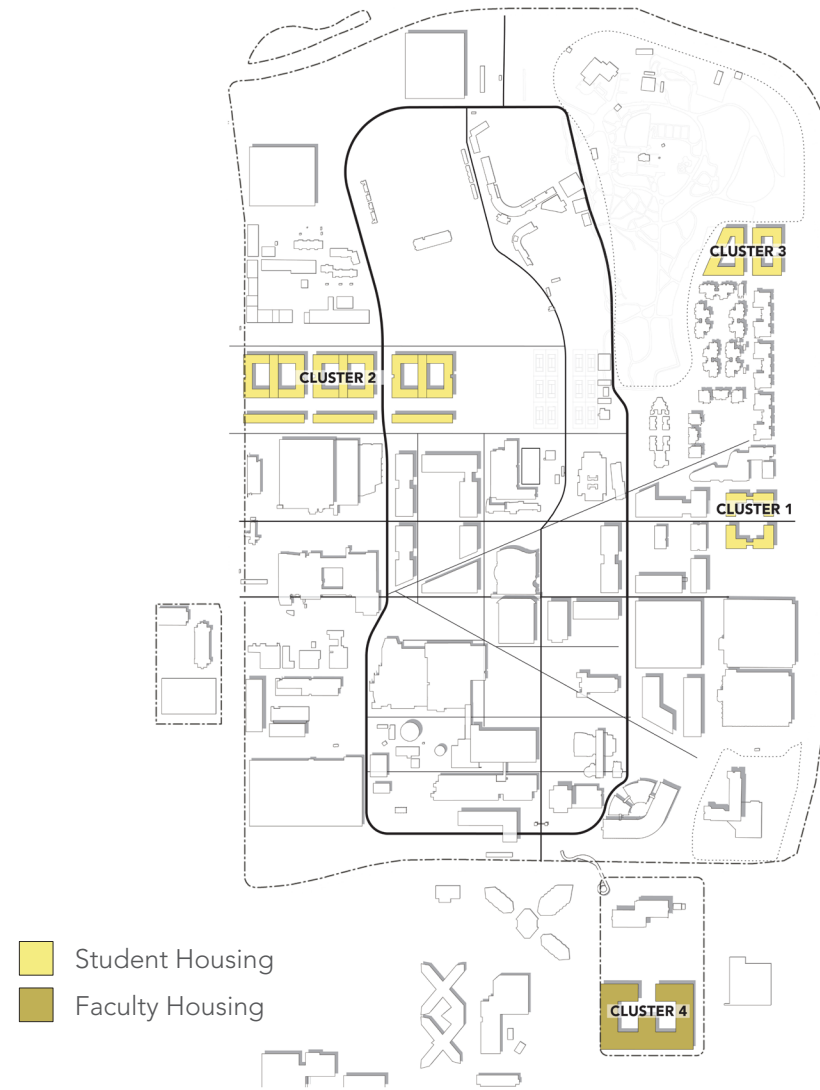


Table 5. Student Housing and Student Life Program

Student Housing	Footprint (sqft)	Number of Floors	Gross Area (sqft)	Total Number of Beds (~335 sqft/bed) <sup>1</sup>
Cluster 1	33,000	6	198,000	600 (Proposed)
Cluster 2	133,980	6	803,880	2,400 (New)
Cluster 3	33,495	6	200,970	600 (Replacement)
<b>Total</b>	<b>196,475</b>	<b>-</b>	<b>1,298,420</b>	<b>3,600</b>

Table 6. Faculty Housing Program

Faculty Housing	Footprint (sqft)	Number of Floors	Gross Area (sqft)	Total Number of Units (~1,540 sqft/unit) <sup>2</sup>
Cluster 4	89,833	6	539,000	<b>350</b>

### Key Considerations

- It is imperative that all housing structures include integrated student life programming, and the Plan accommodates for this by considering taller residential buildings (5-7 stories) and planning for student-life spaces to occur on the lower levels, especially the ground floor. This includes spaces outside the dorm room for students to hang out, meet and socialize, and places for group and individual study, and should also include opportunities to relax, and provide access to recreation.
- Also critical to the success of providing on-campus living for a significant population of students is to simultaneously include student amenities spaces in and near student housing. To support a 24/7 campus environment that is necessary with students remaining on campus full-time, amenities would include cafés or cafeterias as places to grab a healthy meal or snack, and small convenience stores or places to buy supplies.
- Student life and amenities spaces need to be provided in various locations across campus to support non-residential students as well, allowing for students to remain on-campus and to take advantage of activities and programs outside of classroom hours.
- Student life program and amenities spaces need to be visible, safe, and accessible at all times, for residential and non-residential students alike.



1. The Pomona College Student Housing in Claremont, CA - EYRC Architects



## ACADEMIC AND STUDENT LIFE

While the planned additional building area directly addresses entitlement shortfalls and accommodates for 1 percent growth across all majors, the campus is focused on serving the community and planning for overall growth rather than targeting any specific discipline in terms of academic emphasis or recruitment. Therefore, the academic buildings in the Physical Master Plan are intentionally not assigned to departments or disciplines to allow for maximum flexibility.

Consideration for districts and neighborhoods is outlined and individual academic building assignments will be defined as needs dictate. In consideration of preserving open space and planning for the highest and best use of campus land and allowing for future growth, buildings are infilled within the academic core and are planned to be six stories in height. Buildings are conceived to have generous corridors with classroom or lab spaces and student life program flanking the corridors.

The widths of the floorplates (80'-90') and 15-foot floor-to-floor heights allow for good daylight penetration into occupied spaces. Integrating student-life spaces within academic buildings supports 21st century learning by providing informal learning spaces outside of a classroom or lab for study sessions with other students, meeting with a faculty member, and for individual study and is imperative to the success of development. Other building programs that support campus academic and student life are the Innovation Hub and the Event Center. These are described further in this chapter.



1. *The Pomona College Student Housing in Claremont, CA - ERYC Architects*



**Table 7. Academic and Student Life Program**

Building #	Footprint (sqft)	Academic		Student Life	
		Number of Floors	Gross Area (sqft)	Number of Floors	Gross Area (sqft)
A1	25,000	3	75,000	2	50,000
A2	22,000	4	88,000	2	44,000
A3	10,000	3	30,000	2	20,000
A4	25,000	-	-	6	150,000
A5	40,000	4	160,000	2	80,000
A6	18,000	4	72,000	2	36,000
A7	9,000	4	36,000	2	18,000
A9	14,000	3	42,000	3	42,000
A10	30,000	4	120,000	2	60,000
A11	17,000	3	51,000	2	34,000
A12	11,000	3	33,000	2	22,000
A13	13,132	4	52,526	-	-
A14	20,000	-	-	6	120,000
A15	20,000	4	80,000	2	40,000
A16	21,000	2	42,000	4	84,000
Total			<b>881,526</b>		<b>800,000</b>

### Key Considerations

- Informal learning spaces must be incorporated within the floorplate and in the planning of the programs of all academic buildings.
- Informal learning and other student life spaces should occur on the ground floor and be visible from adjacent circulation paths (front porch). These spaces, especially on the ground floor, should be accessible and remain well-lighted and safe outside classroom hours.
- Flexibility of academic building planning can also support cross-disciplinary curricula and collaboration. Renovations of existing buildings must also consider incorporation of informal learning and student life spaces.





## EVENT CENTER

Event Center program would include replacement spaces from the KHS building with space for sporting events, concerts, graduation events and job fairs, and would be available for campus and neighborhood community use. The Event Center would not wholly be part of campus academic entitled space but would provide student-life support, a visible flagship identity and opportunities for making connections with the community at large.

Prominent placement of the Event Center near the academic core creates a buzz and forms an active outdoor event plaza and allows for access via the same transportation options used to access campus, potentially alleviating congestion concerns.

### Key Considerations

- Existing parking structures can support Event Center surges.
- An event center would invite potential financial sponsorship and partnership opportunities.
- This building type can be more iconic.

Figure 56. Event Center



Table 8. Event Center Program

Footprint (sqft)	Number of Floors	Gross Area (sqft)
84700	3	254,100



1. Price Center UCSD (Left)
2. California State San Marcos (Right)

## INNOVATION HUB

An Innovation Hub would be centered in the academic core, and while not part of academic entitled space, the building program would be developed to directly support the campus' mission to promote multi-disciplinary learning, to foster industry partnership and drive entrepreneurship. The building will not belong to any specific department but will be operated by the overall campus. Spaces will include flexible rooms for lecture or large group gatherings, maker-space, computer labs, rooms of various sizes to accommodate club meetings, study groups, meetings with members of the business community, and will have state-of-the-art technology. Like other proposed buildings, the Innovation Hub is mindful of its footprint and its relationship to open space.

### Key Considerations

- Opportunity for iconic architecture – a significant 'foreground' building.
- Building should be harmonious with historic academic core.
- Building should promote shared resources, transparency and openness.
- Building connects to major axes and to central open spaces.

Figure 57. Innovation Hub



Table 9. Innovation Hub Program

Footprint (sqft)	Number of Floors	Gross Area (sqft)
14553	5	72,762



1. California College of Art, SF (Left)
2. Florida State University (Right)



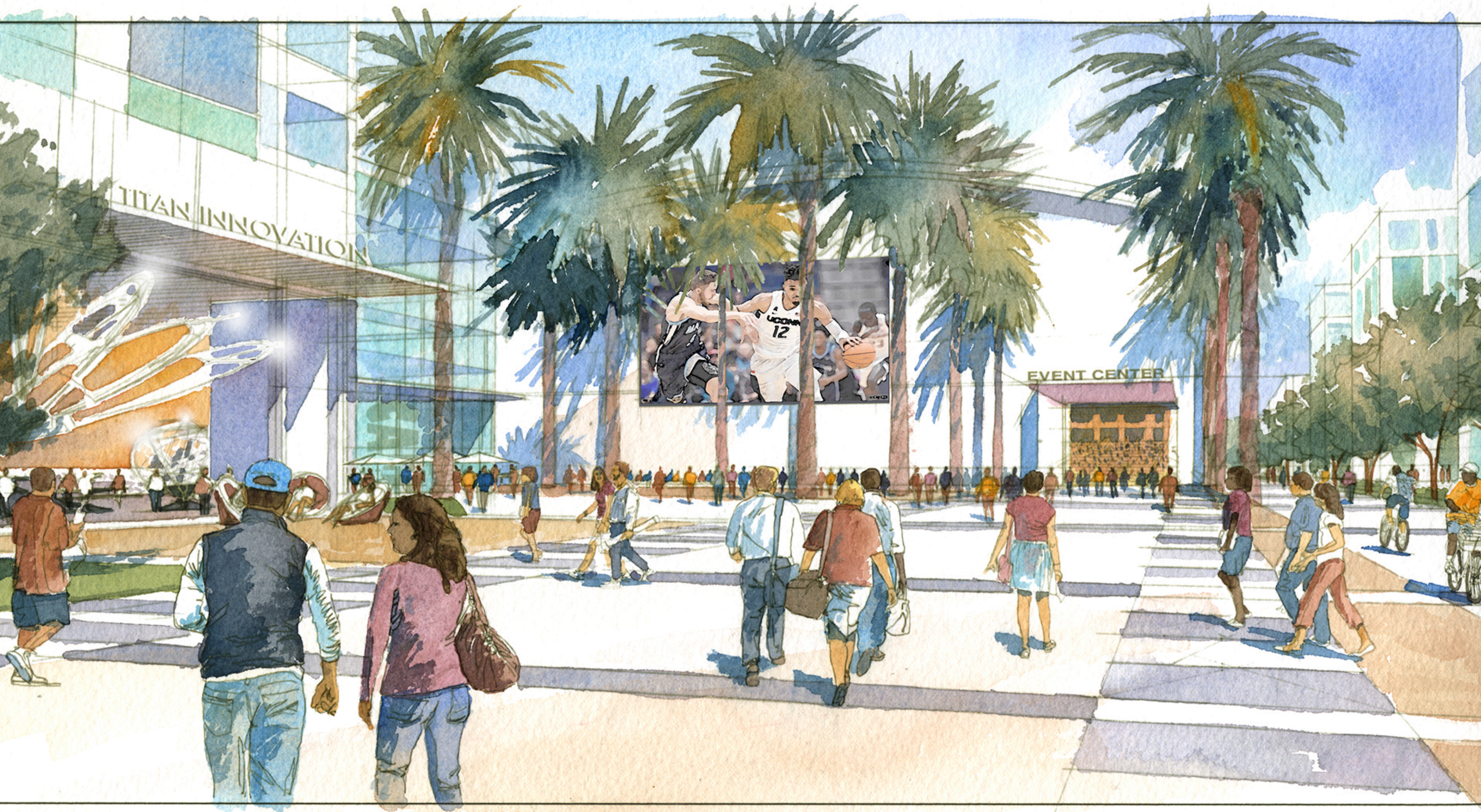


Figure 58. Perspective View of Proposed Event Center



## PARKING STRUCTURES

With successful and timely implementation of transportation demand management (TDM) strategies and bringing student housing clusters on line, expending capital on parking structures may be significantly delayed and would allow for construction projects to be focused on academic development.

### Key Considerations

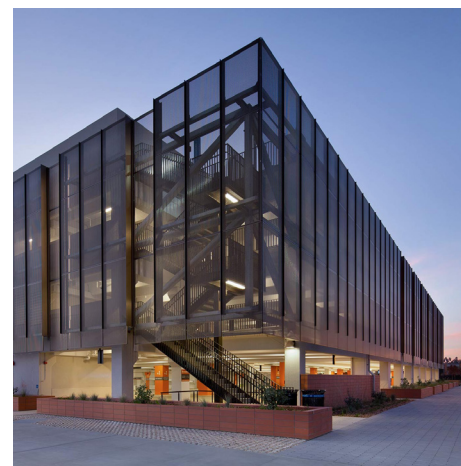
- Reduce parking demand by implementing TDM strategies, including more on-campus student housing, will transform the character of the campus.
- TDM strategies will relax traffic impacts and allow for more efficient travel to and within campus.
- Students and faculty can spend more time learning and teaching and less time considering commuting stresses.
- Parking must be self-funded and is not supported by State funds.

Figure 59. Parking Structures



Table 10. Parking Structure Program

Footprint (sqft)	Number of Floors	Gross Area (sqft)
~140,000	6	838,688
~140,000	6	838,687



1. Santa Monica Parking Garage (Left)
2. Hoover Garage, Stanford (Right)

## ARBORETUM

The Physical Master Plan preserves the Arboretum as an asset to the community while making stronger connections to the campus, its academic curriculum, and recreational and relaxation needs. Plans within the Arboretum itself will be limited to improving or replacing support buildings and providing development that supports the mission of the Arboretum. Seeking opportunities to enrich the value of the Arboretum as an asset to academic programs, the Physical Master Plan proposes better campus-side connections to foster classroom activity and respite for students, faculty and staff.

### Key Considerations

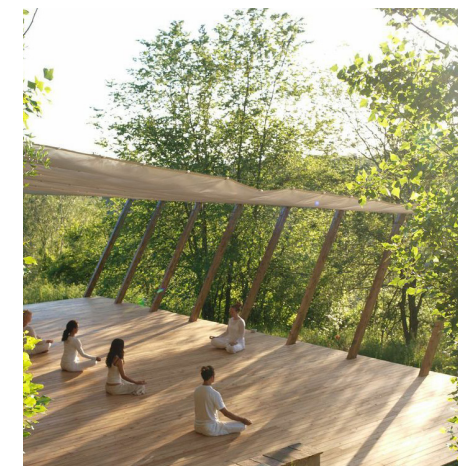
- The Arboretum will need to maintain a secure boundary to protect priceless assets.
- The Green Loop connects the Arboretum and other green spaces on campus.

Figure 60. Arboretum Buildings



Table 11. Arboretum Program

Program	Gross Area (sqft)
Arboretum Facilities	100,000



1. Spaces for Outdoor Wellness (Left)
2. Pleasant Ridge Wellness Camp (Right)





# Open Space

The open space, especially in a mild and inviting climate like Southern California, defines the identity of a campus just as much if not more so than its buildings. Increasingly, the attractiveness of the public realm has been a top consideration for university choice. In a campus environment, the open space serves many purposes, often becoming an extension of the classroom. By creating a welcoming public realm, the university is indicating to prospective and existing students, faculty, and the community that it is a desirable place to be. To this point, 79 percent of current students were attracted to CSU Fullerton because of the quality of outdoor spaces, landscaping, and art—the top reason beyond academics for choosing the institution. Yet, through the engagement process, it was revealed that significant improvement in the landscaping and open space was desired from both students and faculty.

This open space plan envisions nine distinct components that when executed in tandem will make a cohesive and vibrant campus. The plan applies to both existing and proposed open space areas. Each

component serves a specific purpose and relates directly to the overall vision for the campus as a whole. All components also operate on different scales and thereby serve different programs and purposes. The components seek to define all aspects of the public realm, including axes and main circulation through the campus and a variety of spaces for lingering and connecting with others.

The open space goal is an extension of the overarching goals of the university; to be an attractive environment that promotes and fosters intellectual growth while bringing diverse people together. While this undoubtedly happens in the classroom, the intention of this open space plan is to extend the classroom to the public realm and create external areas that foster identity and pride. Front porches and courtyards continue the conversations that happen within the classroom. Plazas and greens will become the stage for events, activities, and recreation. By making a campus where students want to linger, their educational process begins as soon as they step on campus.

---

## OPEN SPACE GOAL

Situate buildings and create open spaces that foster and promote intellectual growth and bring *diverse* people together to *expand* thought.

---



Figure 61. Open Space Illustrative Plan



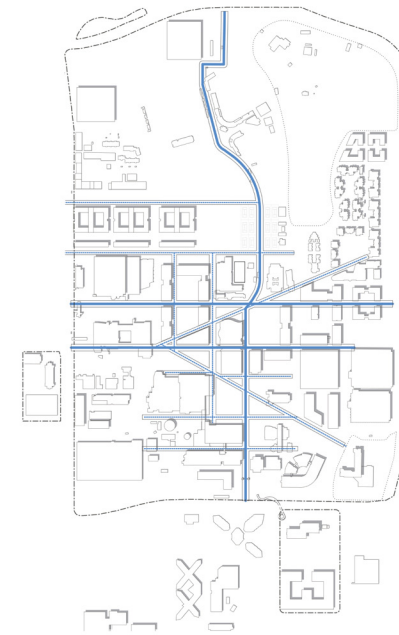
## OPEN SPACE ELEMENTS

Figure 62. Open Space Elements



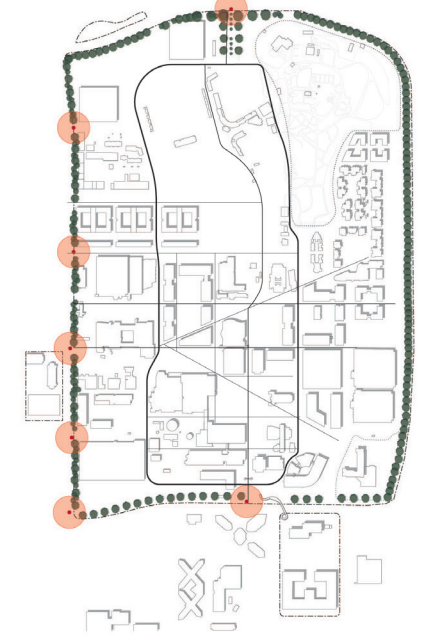
### Green Loop

The Green Loop encloses the core of the campus and connects to every major building. Major uses, such as the arboretum, student housing, the student union, the event center, and academic buildings all “hang” off the “necklace” of the green loop. While both a practical connection for bicycles throughout the campus, it can also serve a recreational purpose.



### Axes

A hierarchy of axes are located throughout the campus, with clear east-west and north-south connections to assist with legibility of the networks. Two diagonal pathways direct students to the heart of the campus, the Student Union. This network, paired with the Green Loop, provides walkable and bikeable access to the entire campus.



### Perimeter

The perimeter establishes a clear separation between campus and its adjacent land uses. It serves as a threshold upon which learning begins. At key entrances gateway treatments signify the importance of entering. Around the rest of the perimeter, various types of planted buffers serve different purposes that respond to the land use context.





**Plazas**

Plazas are gathering spaces for both small connections day to day and more formal, large events, such as graduation and the first day of school.



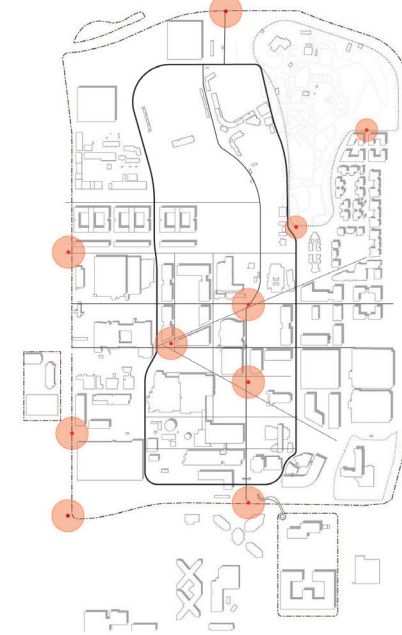
**Courtyards**

Courtyards all share the element of enclosure, either completely or partially, but the design elements shift depending on the program of the adjacent buildings. In an academic courtyard, the space may be an extension of the classroom while a residential courtyard will serve as semi-private public space for the residents. Courtyards establish smaller “rooms” in the public spaces of a campus.



**Greens**

Greens are also a gathering space for both small connections and larger events, with the main differentiation being the surface treatment. Greens consist of permeable surfaces where plaza design treatments tend to have pavers or impermeable surfaces. Greens, along with courtyards at times, help to distribute the green of the arboretum throughout the campus.



**Art and Identity**

Public art in the open space can be used to both signify importance of specific places around campus and also an orientation method for wayfinding. Public Art should celebrate the open space and also display the values of the institution.



**Front Porches**

While open space and the built form should always be considered in tandem, the entrances of buildings should receive special attention. Front porches situated onto main axes blend the divide between indoor and outdoor spaces. Front porches offer an opportunity for the internal program of the building (i.e. engineering, humanities, etc.) to flow out into the open space and conversely draw people in.



**Arboretum**

While there are few changes proposed for the arboretum, it is the most significant open space on the CSU Fullerton campus and the most beloved. Our master plan outlines how this cherished resource will remain as well as make connections to it more seamless.

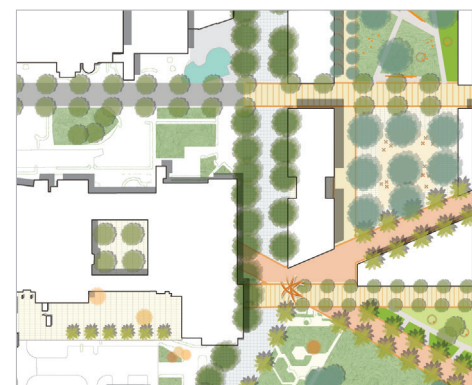


# GREEN LOOP

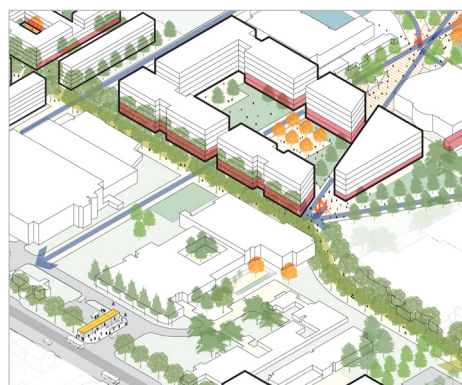
Historically in 1969, foundation of Cal State Fullerton was laid on So-Cal agriculture fields like any other Cal State Campus of that era. The plan was laid out with a central academic core surrounded by agricultural fields and some surface parking. An internal circulation loop has become a key organizing framework for the campus and has defined the campus core. The form and shape of this historic loop was lost by mid 1990s, but its primary function as a robust internal circulation loop tying the south and north campus stays quite relevant today. This master plan proposes the revival of the historic green loop as a key campus framework element.

The green loop will be the primary multi-modal internal circulation for the campus for pedestrians, bikes, and a variety of micro-mobility options; along with providing EVA access. As detailed in the design guidelines, the future building must carefully align to the proposed green loop geometry to catalyze the revival of the campus historic loop. It is planned as a major boulevard south of Gymnasium Drive with a central circulation path and variety of Campus life functions while in the north it serves as a wellness trail to support the athletic functions.

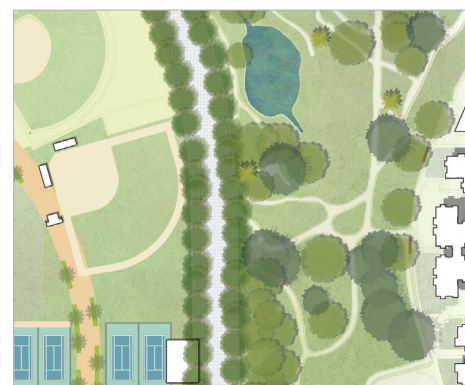
Figure 63. Green Loop



The Green Loop changes its character and form as it weaves through the campus from being the primary circulation to defining the to-build setbacks.



Green loop provides an circulation hierarchy as well as stitches existing and new buildings together.



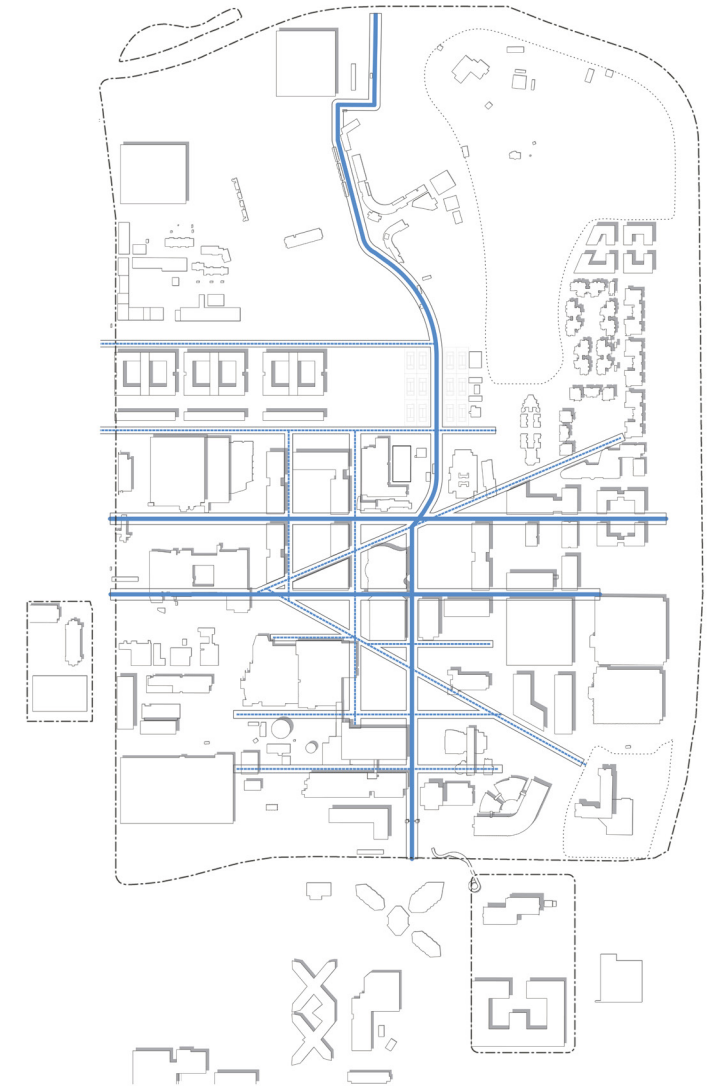
Green Loop is proposed to be the health and wellness trail, with large shade trees, running tracks and bike trails.

# AXES

The axes are primary pedestrian and micro mobility connection across the campus. As the Green loop, the campus axes also define key framework elements for the Master Plan 2039. This plan defines two hierarchy of the campus axes, primary and secondary. The nodes where these axes intersect are recognized as keys areas for campus identity creation, public art and plazas.

- The primary axes are the major north-south and east-west paths connecting campus entrances, mobility hubs and parking garages to the campus core. These also serve as EVA access routes. The longer faces of the buildings are carefully aligned with the idea of creating primary access to buildings from these circulation corridors.
- The secondary axes are the shortcuts through the campus, weaving through spaces and indoor corridors. They are envisioned as paseos as more intimate spaces for circulation and social gathering, each having its own identity and character. Titan Walk is recognized as one such secondary axis and proposed to extend towards the southeast corner of the campus.

Figure 64. Axes



The Axes are direct pedestrian routes connecting campus gateways to major functions in campus core.



The campus axes and open space create a delicate network of connected public realm on the campus.



The diagonal axes are key opportunities for creating campus identity, art and way finding elements.



Figure 65. Green Loop Perspective Illustration





## PERIMETER

The perimeter of campus achieves multiple objectives for the open space plan by exhibiting the identity to the greater community. Depending on the adjacencies of the perimeter, different design treatments should be applied.

### Key Considerations

- On the western and northern edges, given the residential neighbors, a mature tree canopy and beautifying plant buffer should be applied on the entire length of N State College Boulevard. Key exceptions include the entrances along the corridor to the campus and the connection to the Extension campus. All entrances should break the perimeter and be demarcated with contextually appropriate signage.
- On the eastern edge of campus, a large buffer with both a tree canopy and ground level plantings will create a clear boundary between campus and Highway 67. Existing trees should remain with additional trees planted where needed.
- Along Nutwood Ave, a more porous line of street trees should be planted to enable fluid movement.

Figure 66. Perimeter



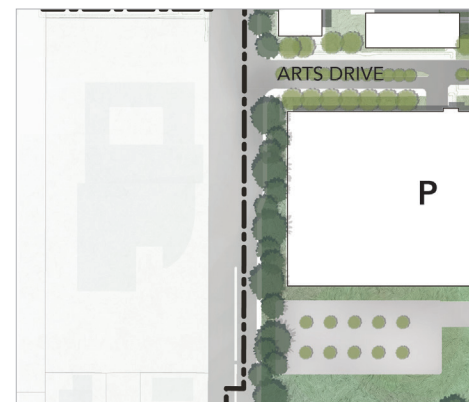
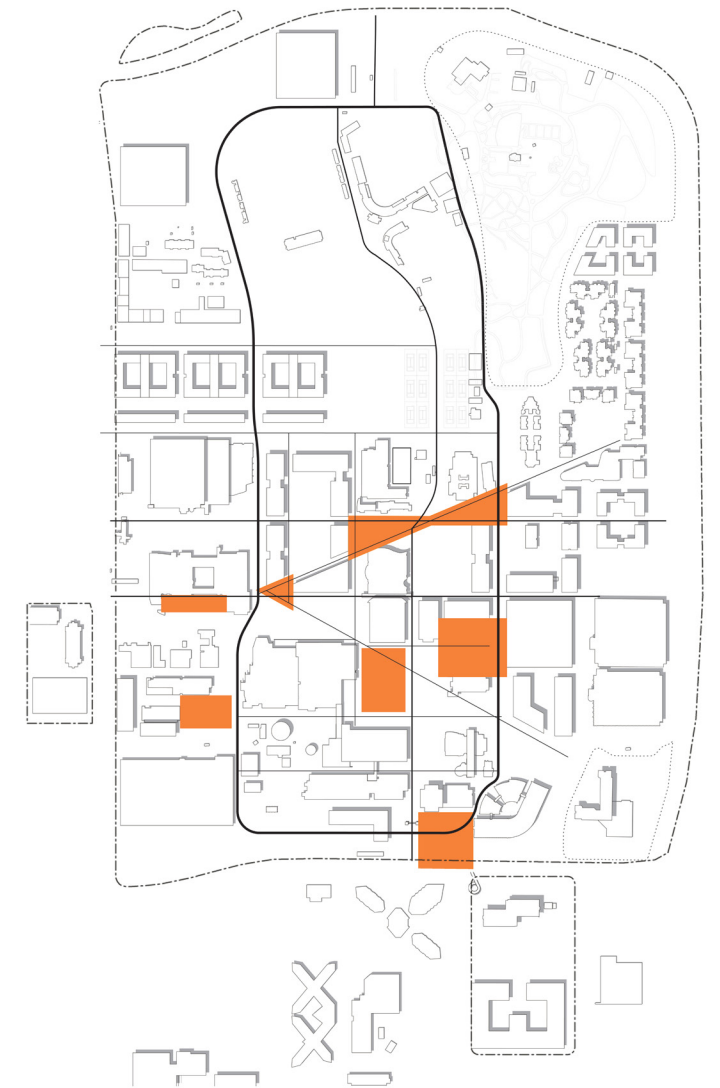
## PLAZAS

Plazas provide both connections and destinations throughout the campus. They must be designed to satisfy the needs of major events (such as graduations or outdoor gatherings) and also function day to day as a place for lingering. It should be a space that can be used to display student art.

### Key Considerations

- Flexible use must be prioritized creating a space that can be used every day of the year and throughout the day.
- Plazas will function as congregating places and thus must have some forms of seating- likely in the form of seat walls.
- Shade must be incorporated into the design, whether through trees or shade structures.
- While the main plazas on campus are the Quad and the Entryway plaza, this plan envisions multiple new plazas located throughout the campus, including the Event Plaza and Bow-tie Plaza.

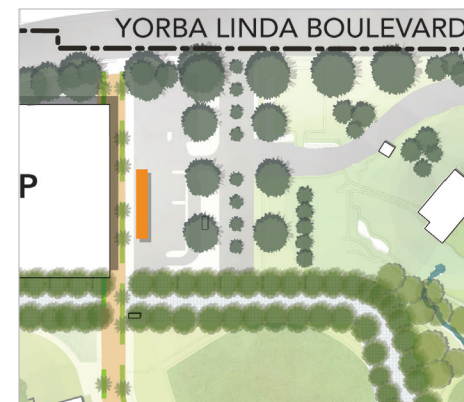
Figure 67. Plazas



Landscape buffer with tall trees on State College Blvd and highlighting key campus entrances



Dense landscape buffer along the highway to block noise, light pollution and air pollutions.



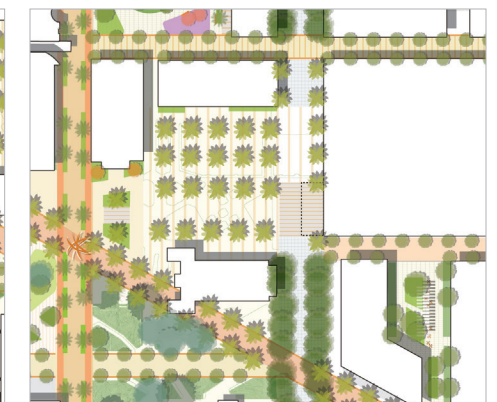
Creating a new campus entry on Yorba Linda Blvd, along with a mobility hub.



Bow-tie Plaza is the new dynamic open space on the campus connecting academic core to student housing.



The Main Quad is the heart of the campus and needs revitalized to support evolving student life.



Event Plaza is a large flexible space supporting programs at Event Center and Innovation Hub.





Figure 68. Bow-tie Plaza Perspective Illustration



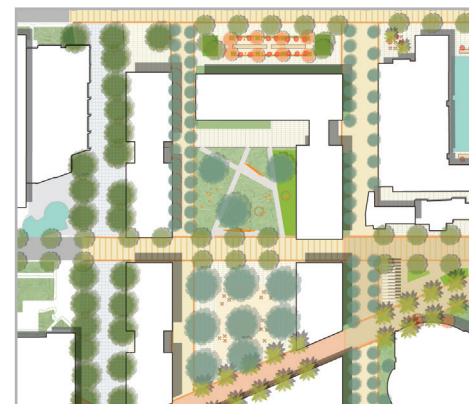
# COURTYARDS

Courtyards are some of the smallest scaled open space types, one that is more intimate and reflects the programs of the adjacent buildings. They are defined by the buildings that frame them. Courtyards present the chance to add variety to the public realm on the campus by each establishing a unique identity. Because of their small size, courtyards can vary in greater degree without diluting the overarching identity of the entire campus.

## Key Considerations

- Multiple entrances should open onto the courtyard with at least one external entrance.
- Courtyards should be flexible spaces- that provide for passive recreation/activity and on occasion small events.
- At-grade uses should be employed to activate the space (either retail, café, or other uses).
- Adequate shading should be provided in seating areas as well as ample lighting for night time activities.

Figure 69. Courtyards



A large academic courtyard is proposed north east of the existing Titan Student Union.



Residential courtyards in more detail.



Courtyards can be entirely closed or open onto axes, as demonstrated above.

# GREENS

Greens serve a similar goal as plazas in so much as they are places for gathering. The main distinction lies in materials used. Greens are largely permeable places that can have people linger on them while also providing much needed open space throughout the campus. It extends the green identity of the arboretum to the entirety of campus.

## Key Considerations

- In greens that are intended primarily for recreation, there should be a relatively flat grade. The green located just south of the sports area has an explicit recreation purpose and should be reserved for that use.
- Flexible uses should be prioritized so that a multitude of activities can occur, from events to informal gathering.
- Consideration around appropriate plantings for the climate must be incorporated into the design.

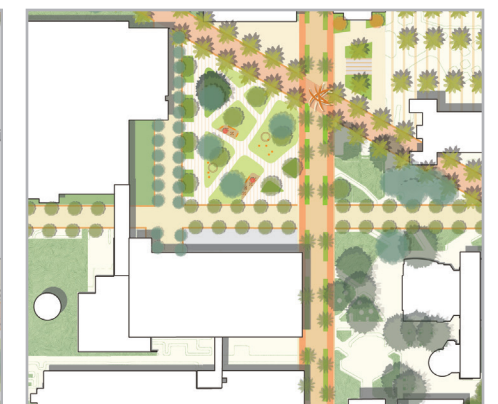
Figure 70. Greens



Below Bow-tie Plaza, a green is proposed in this key node on campus..



A green is proposed as a counterpart to the formality of the adjacent areas of Bow-tie Plaza.



The main quad has dual purposes and has features of a plaza and green within it.



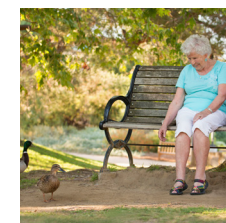
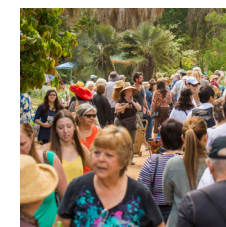
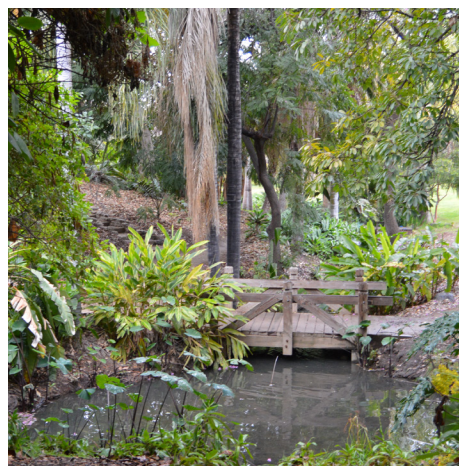
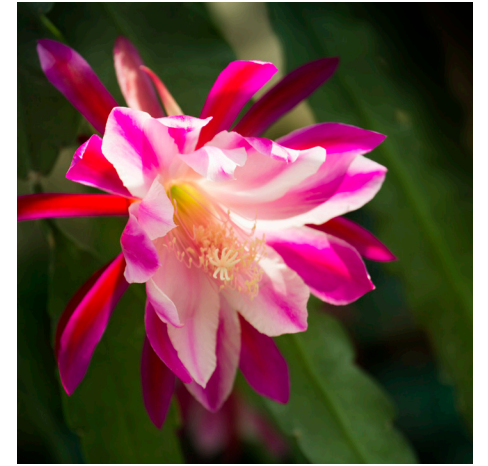
# ARBORETUM

The arboretum is one of the most beloved parts of campus and yet has few points of connection to it. Students and faculty articulated a stark disconnect between the arboretum and the rest of campus. This plan doesn't envision significant changes to the arboretum itself, with the only addition of better connections to the entrances (through the green loop). While physical changes are not included, programmatic changes should be considered to better integrate the arboretum into the curriculum of the university. It is an incredible resource and is often read as separate from the university.

## Key Considerations

- Improve connections from the main campus through the green loop (potential entrance on the southern most area of the arboretum).
- Fence is to be maintained as there is concern around theft.
- The arboretum is important to the Fullerton community beyond just the student body and should be maintained as a community asset.

Figure 71. Arboretum





## FRONT PORCHES

A crucial element of this master plan is to break down the artificial barriers that hide the members of the Cal State Fullerton community from each other. This manifests in ground floor transparency of buildings and is focused around a front porch area of every major building.

### Key Considerations

- Porches should face onto main axes or the green loop.
- The ground floor of the building should have a transparency to it.
- The front porches should be designed for lingering through seating components and other activation efforts.
- The front porch should have an indication of the building's programming.

Figure 72. Front Porches



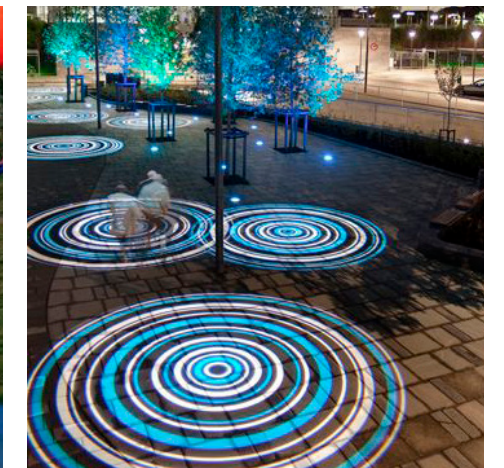
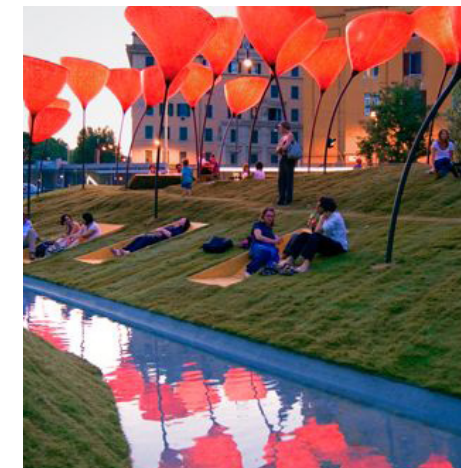
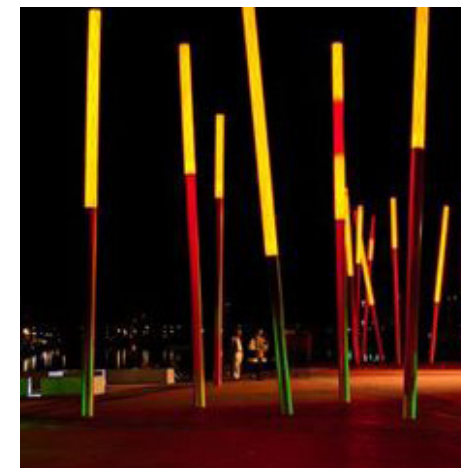
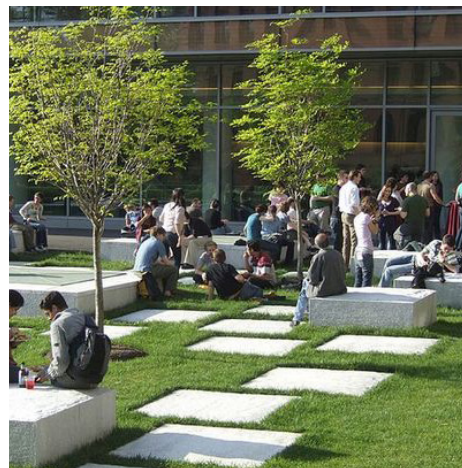
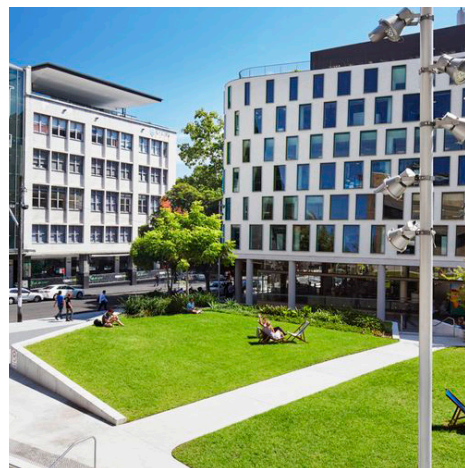
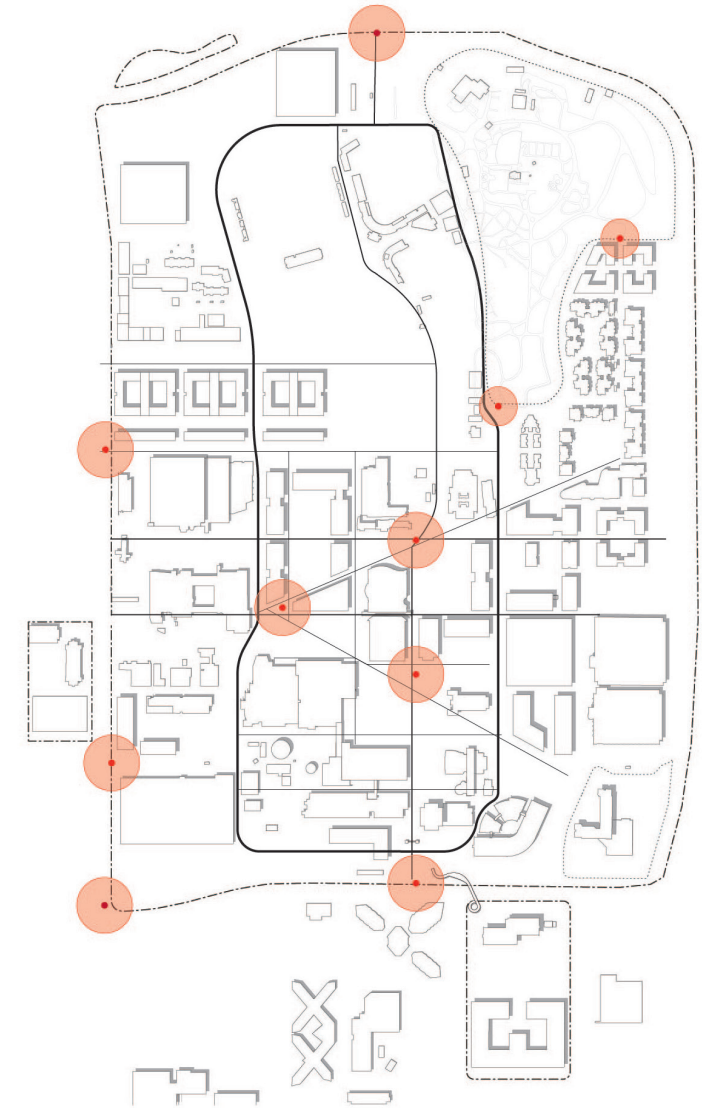
## ART AND IDENTITY

Public art should be strategically located throughout the campus to reinforce the Cal State Fullerton identity and communicate the stated values of the institution. 56 percent of student responses said that Art and Cultural artifacts should be used as a way to illustrate Cal State Fullerton's values. The placement of the art should occur at key nodes to lend itself to the legibility of the campus.

### Key Considerations

- Public Art should be strategically spaced so that it does not impede axes but also draws significant attention to the area.
- The subject matter could represent the values of the student body, including equity, diversity, and sustainability.

Figure 73. Art and Identity







# Mobility

Improving internal campus mobility and external access can kick-start a positive feedback loop of benefits for Cal State Fullerton and the surrounding area. The loop occurs between the functions of trips, parking, and traffic. For example, the impacts of new growth will have to be reviewed as per state regulations (CEQA); reducing the negative impacts of growth (increase in auto trips generated is a major negative impact) will permit the University to experience growth at a healthier rate.

Activation of a TDM Plan facilitates an overall reduction in vehicle trips generated by the University and can serve as CEQA mitigation measures under new CEQA VMT (vehicle miles traveled) protocol. A reduction in overall trips lessens Cal State Fullerton's impact on the local network, reducing conflicts for non-motorized modes and inefficiencies for transit and shared ride commuters.

Reducing vehicle trips also reduces demand for parking that can save the University significant amounts of fiscal and land resources for uses that are better in line with Cal State Fullerton's mission. Often, it is less expensive for a university to adequately meet campus access needs through significant TDM investments than expansion of roadway capacity and parking supply to accommodate growth.

In addition, allowing more students to live and accommodate daily needs on campus inherently reduces their trips through internal capture – in addition to positive academic outcomes such as a correlation with increased graduation rates and satisfying the overall objective of creating a 24/7 campus.

---

## MOBILITY GOALS

- Decouple campus growth from increases in VMT and parking demand by providing effective transportation alternatives for accessing campus by means other than driving alone and providing sufficient on-campus or nearby housing and amenities to encourage trips by non-motorized modes.
  - Enhance the pedestrian, bicyclist, and transit rider experience by creating an internal circulation network that logically and safely accommodates all users regardless of ability and reduces first/last-mile barriers to improved options for external connectivity.
-

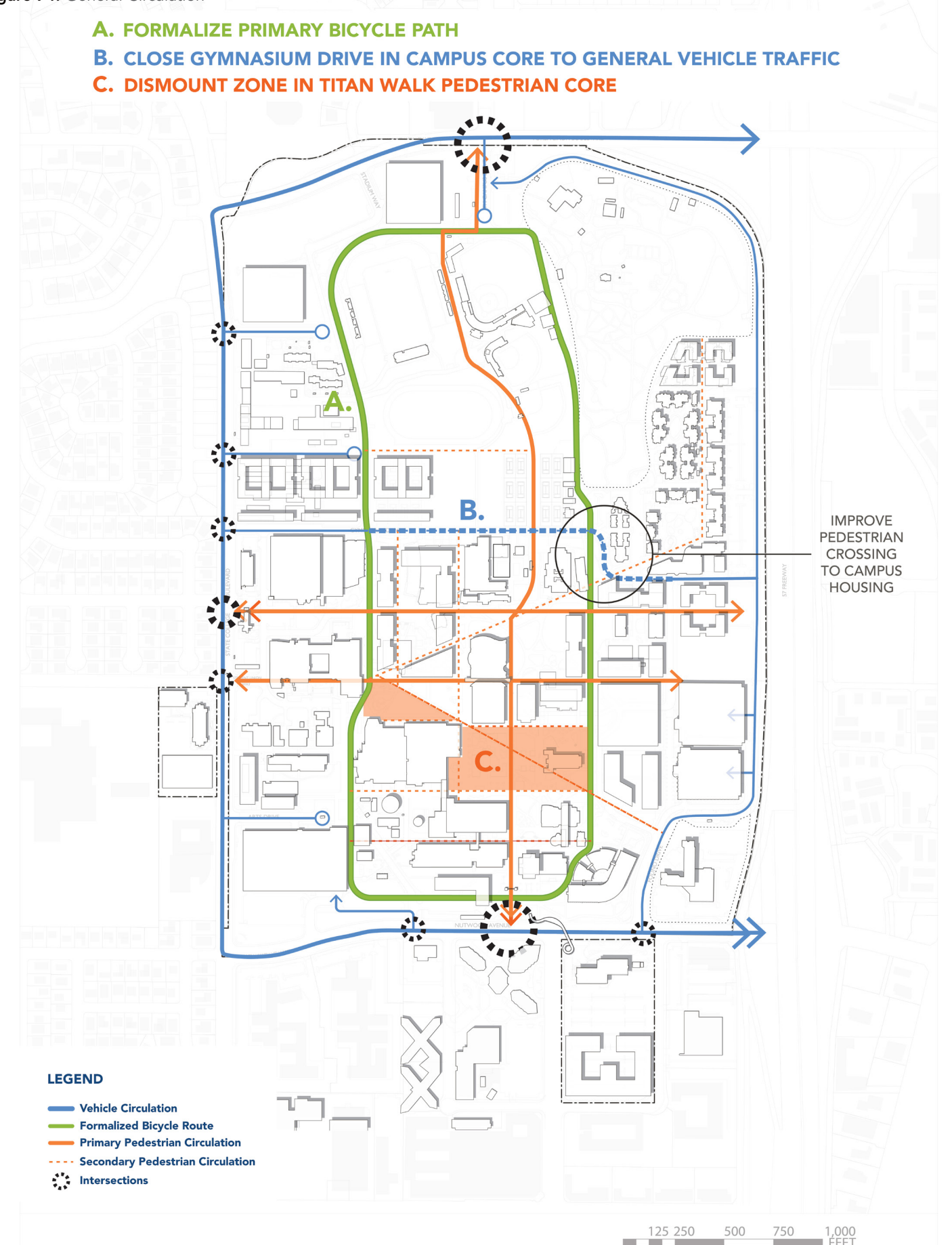


# GENERAL CIRCULATION

During outreach and internal feedback stages of the Physical Master Plan process, participants provided many suggestions on ways to improve internal circulation at Cal State Fullerton. The campus is small enough that many preferred walking, skateboarding and kick scooters to bicycling for internal trips, and there was a general sentiment that although there were some promising recent enhancements and the core of campus is increasingly walkable, there were many impactful improvements that could make internal circulation function better for all users. During working group feedback, participants even went so far as to note that improved multi-modal circulation organization on campus was perhaps the most important mobility need. Recommendations to improve internal campus circulation include the following:

- Increase level of separation between pedestrians and vehicle traffic.
- Preserve and expand the core pedestrian zone in the heart of campus.
- Close a non-critical segment of Gymnasium Drive in the campus core to vehicles to improve walkability and safety.
- Improve the hierarchy of internal circulation, including walkway hierarchy and consistency, and improvement of intuitive design of all paths, including bicycle route.
- Better organize and mark walking paths.
- Prioritize physical improvements to conflict points for vehicles, people walking, and people biking, including Campus Drive and Gymnasium Drive, and the pathway across Gymnasium drive between the academic core and student housing area.
- Clarify overall circulation rules, for where bicycling, skateboarding, and scooters are allowed.
- Improve overall quality of pedestrian and bicycling signage and wayfinding. Create overall wayfinding system that emphasizes walking, biking, and transit.
- Improve the markings, signage, and organization of bicycle routes. Reduce confusion about what travel modes are allowed, and where.
- Where bicycle access terminates to the center of campus, provide bicycle dismount and parking zones – not just “Do Not Enter” signs.
- Formalize and establish a more legible circulation system that prioritizes pedestrian travel across campus – important for identity, placemaking, and mobility.

Figure 74. General Circulation





## EXTERNAL CIRCULATION

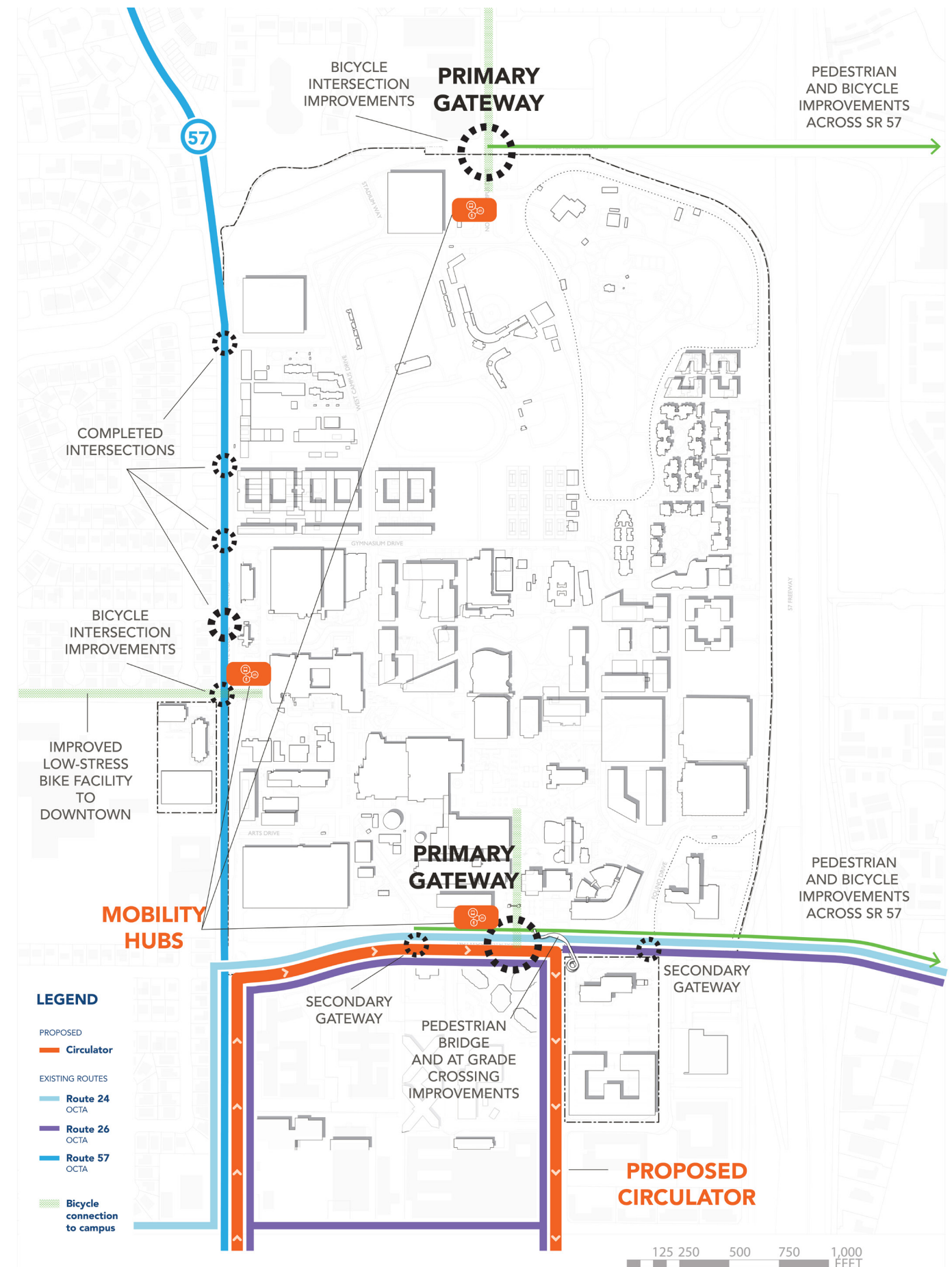
State Route 57, which is a major freeway as wide as 14 lanes in the study area, poses a significant barrier to bicycles and pedestrians. To reduce this barrier, and better connect the sizable student population that lives directly east of SR-57 with campus, Cal State Fullerton should collaborate with the City to provide **designated bicycle facilities and lower-stress** accommodation of pedestrians across the freeway along Nutwood Avenue and Yorba Linda Boulevard. In addition, these improvements should be aided with enhanced warning and detection treatments and vehicle speed calming techniques at the ten on/off-ramps that present conflicts with non-motorized users along the corridors.

Dorothy Lane (which becomes Student Union Way on campus) provides the only designated bicycle route between Cal State Fullerton and downtown Fullerton/Fullerton Transportation Center. From State College Boulevard to Acacia Avenue the facility is a Class II bike lane providing a medium level-of-stress for users. West of Acacia Avenue, Dorothy Lane is only a Class III "sharrow" that provides shared lane pavement markings and bicycle route signage, but low levels of protection and comfort for users. The route meets north-south Class II bike lanes at N. Acacia Avenue and at N. Berkeley Avenue providing access towards downtown Fullerton (via Class III east-west facilities on E. Wilshire Avenue); however, there are no treatments

to increase bicyclist visibility and safety crossing E. Chapman Avenue. To improve this critical multi-modal connection, the University should work with the City to study the feasibility of the following improvements:

- High visibility bicycle crossing treatments at Dorothy Lane and State College Boulevard, Victoria Drive, Acacia Avenue, Riedel Avenue, N. Raymond Avenue, Stanford Avenue, N. Lincoln Avenue, Long View Drive, N. Berkeley Avenue and N. Hornet Way, E. Chapman Avenue, E. Wilshire Avenue, N. Acacia Avenue and Victoria Drive, Nutwood Avenue, E. Chapman Avenue, E. Wilshire Avenue.
- Class II bike lanes on Dorothy Lane from N. Acacia Avenue to N. Berkeley Avenue (via N. Hornet Way).
- Class II bike lanes or Class IV separated bikeway on E. Commonwealth from N. Acacia Avenue or N. Berkeley Avenue to Harbor Boulevard.
- Class I mixed-use pathway along Fullerton Creek from Dorothy Lane to E. Chapman Avenue.

Figure 75. External Circulation





## NUTWOOD BRIDGE / AT GRADE CROSSING

A considerable volume of students, faculty, and staff cross Nutwood Avenue to access University-owned buildings and parking lots, apartment complexes, and third-party dining options that are located south of the main campus. A pedestrian bridge has been planned as the solution for improving the ease and safety of crossing Nutwood Avenue. Pedestrian bridges allow for those walking or using non-motorized modes such as bicycles to cross a congested corridor without conflicts from motor vehicles. The goal of the bridge is to:

- Protect pedestrians and reduce accidents.
- Mitigate neighborhood concerns by reducing vehicle trips and improving traffic flow along one of the city's busiest routes.
- Create an attractive, architectural gateway to the City of Fullerton while reinforcing a sense of place and community.
- Support the Physical Master Plan objective of encouraging walking and biking as transportation alternatives as well as the City of Fullerton's long-standing goal to provide livable streets that cater to pedestrians and bicyclists.

While a pedestrian bridge reduces the potential for conflict, near-term investment in enhanced at-grade crossings of Nutwood Avenue can help to reduce vehicle speeds on the corridor and provide users with multiple safe crossing opportunities. Combining a pedestrian bridge with at-grade enhancements would also improve accessibility for users that

may have difficulty climbing a ramp and allows for greater continuity with at-grade bicycle infrastructure. Crossing enhancements along Nutwood Avenue that may provide a significant benefit for lower cost include a combination of the following:

- Curb extensions.
- Traffic signal modifications.
- Leading Pedestrian Intervals (LPI).
- Refuge island nose extensions to the existing median.
- Rectangular Rapid Flashing Beacons (RRFB).

These treatments would complement proposed improvements from the Fullerton Bike Connection Plan, approved in 2016, to realign sidewalks and driveway crossings to accommodate a new 2-way bicycle path on Cal State Fullerton property along the northern block face of Nutwood Avenue.

Figure 76. Nutwood Bridge Rendering

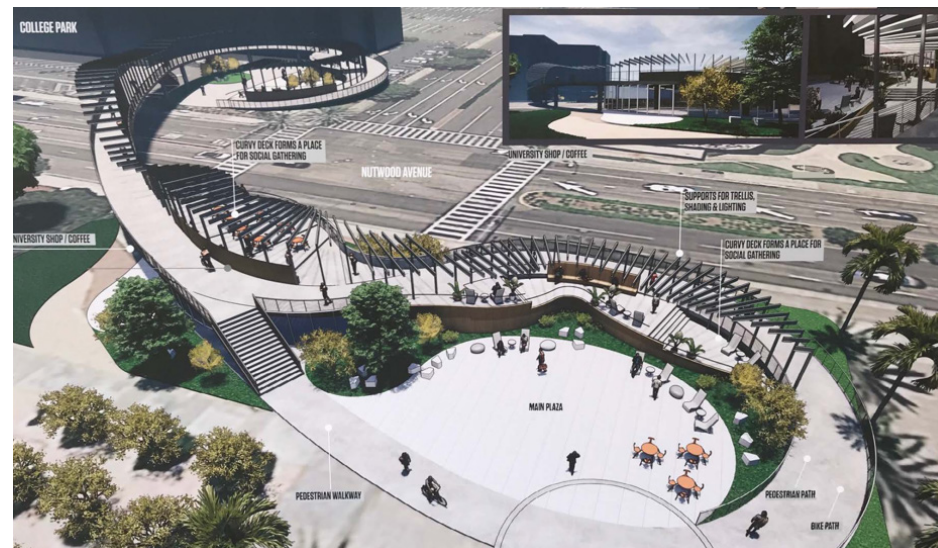
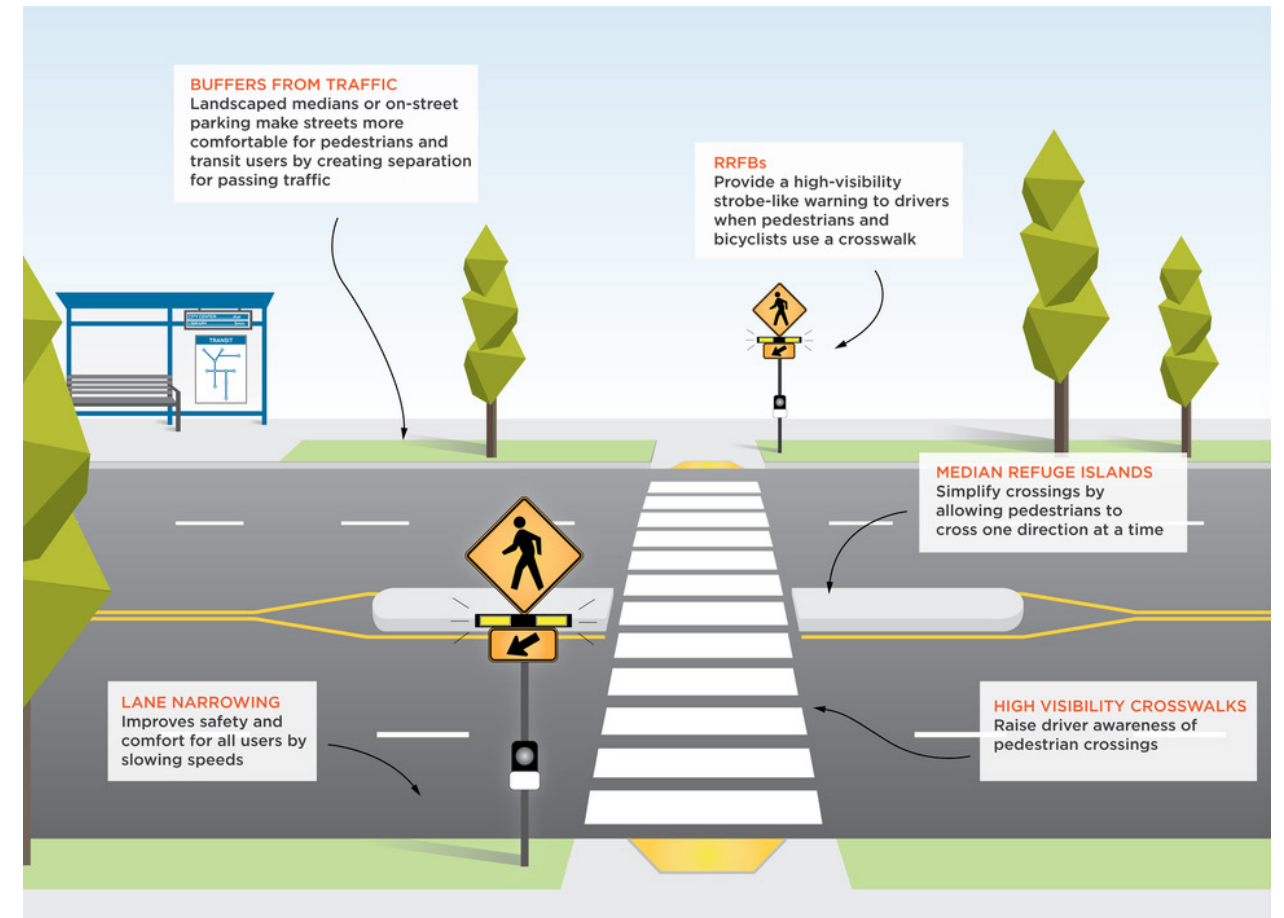


Figure 77. At-grade Street Enhancements



## YORBA LINDA / STATE COLLEGE

Multi-modal connectivity on the north side of campus will be enhanced with proposed improvements to Yorba Linda Boulevard that include removal of the center median to create a Class II bike lane on the southern block face that links to the existing N. Campus Drive and Class II bike lanes on campus with continuation across the SR-57 overpass. In addition, the eastbound Yorba Linda Boulevard to SR-57 northbound on-ramp will be redesigned to reduce vehicular speeds.

Multi-modal connectivity and safety along State College Boulevard can

be improved by reducing conflicts at intersections that provide access to campus such as Sports Drive, Corporation Drive, Gymnasium Drive, Student Union Way and Arts Drive. Each of these intersections has wide curb radii on campus which encourages higher vehicles speeds and limits the visibility of pedestrians.<sup>1</sup> In addition, each intersection on the campus side lacks a marked crosswalk or has a marked crosswalk that is misaligned with ADA curb ramps, providing an indirect path of travel. These issues can be mitigated with curb extensions that help to "square-off" the intersection by narrowing

vehicle turning radii which increases the visibility of pedestrians, reduces crossing distance, and provides space for curb ramps that are directly aligned with their receiving end. In addition, the location of signage, lighting, and utilities restricts the pedestrian right-of-way at multiple locations on the campus side of State College Boulevard. To address this concern, the sidewalk would need to be widened which would require the relinquishment of a northbound travel lane or campus landscaping.

<sup>1</sup> The curb radius refers to the arc of the built curb at the corner of an intersection, which determines the effective turning radius of a vehicle. Reducing the corner radius effectively reduces a vehicle's turning radius and restricts turning speeds. A smaller curb radius also reduces the width of the intersection, reducing the length of the pedestrian crossings and ensuring higher pedestrian visibility by placing pedestrians further into the line of sight for motorists.



# TRANSIT CONNECTIVITY

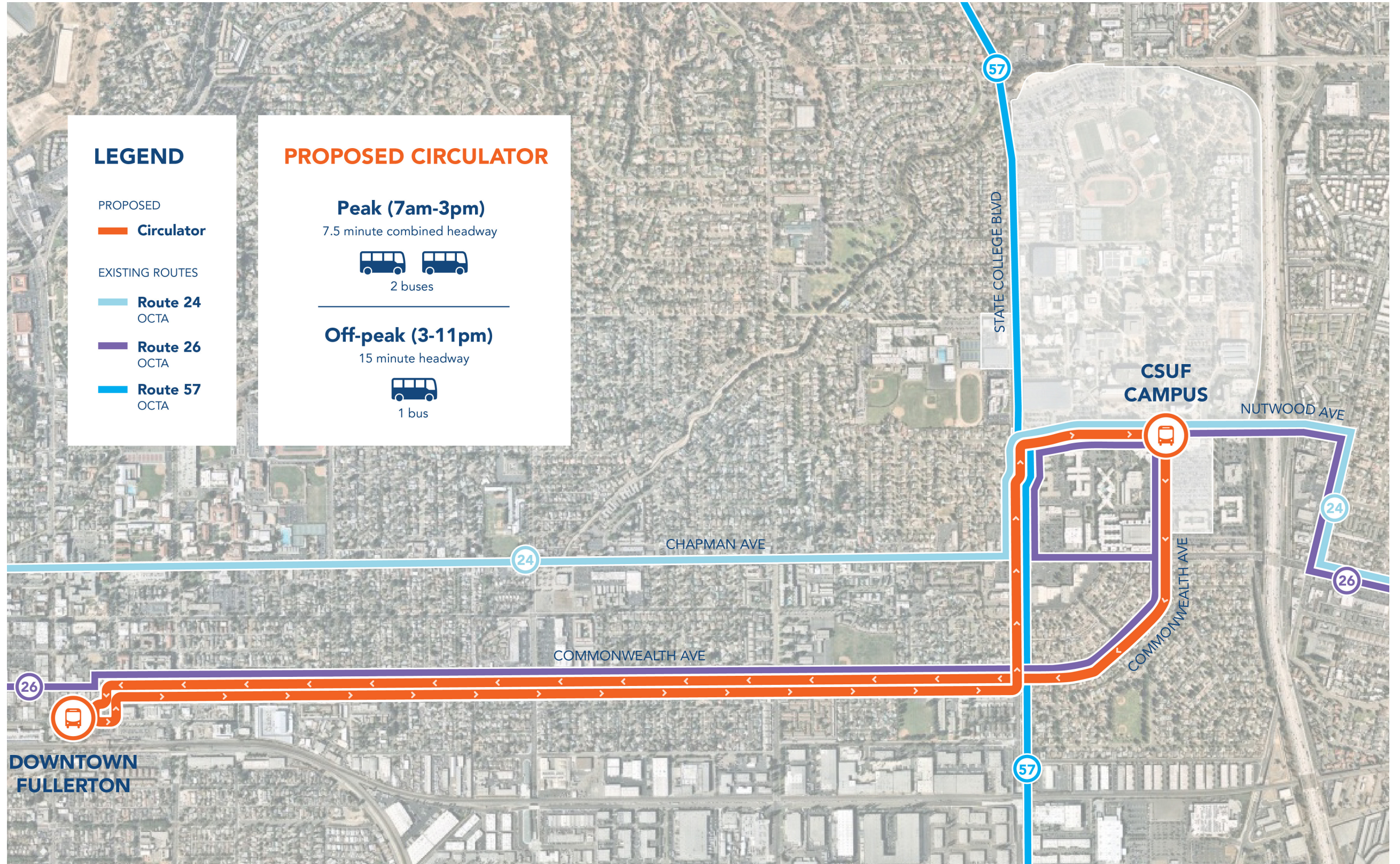
## CAL STATE FULLERTON- DOWNTOWN CIRCULATOR

A critical missing link to campus connectivity is a lack of high-frequency transit service between the Cal State Fullerton campus and downtown Fullerton. In addition to hosting various dining, retail, and service uses that would provide an attraction for future on-campus residents, downtown Fullerton is the location of the Fullerton Transportation Center that serves as the primary regional transit node for Cal State Fullerton commuters.

The station is served by Metrolink's 91/Perris Valley Line (downtown Los Angeles to Riverside County) and the Orange County Line (downtown Los Angeles to Oceanside) in addition to Amtrak's Pacific Surfliner (San Luis Obispo to San Diego). Fullerton is currently the busiest Metrolink stop for commuters in Orange County, with service to increase to a train going through the station every 30 minutes during operating hours by the end of 2020. Existing OCTA Route 26 provides fixed-route bus service between campus and the transportation center at approximate headways of 15 minutes at peak, 30 minutes midday, and 60 minutes in evenings. The trip takes 20 to 30 minutes with frequent stops and is not synchronized with commuter rail schedules.

This service could be offset with a designated CSUF-Downtown Fullerton Circulator service operating at approximate peak headways of 7.5 minutes (with two buses) during peak and midday periods and at 15-minute headways with a single vehicle during the evening.

Figure 78. Typical Internal Street- Auto





## MOBILITY HUBS

Mobility hubs are multi-modal transportation nexus points intended to integrate various transit and mobility services to facilitate a wide range of linked trips.

An ideal mobility hub design for the Cal State Fullerton campus would offer a variety of services and amenities such as:

- Ride-hailing loading zones.
- Circulator shuttle and OCTA transit stops.
- Real-time transit information.
- Electric vehicle charging stations.
- Transit pass sales kiosks.
- Bike and car share parking.
- Secure bike lockers.

Mobility hubs can encourage riders to try more sustainable commutes by reducing first/last-mile barriers to/from transit service and creating a seamless experience between modes. In order to achieve its maximum potential, the mobility hub should be located on-campus to fully integrate transit services with the internal non-motorized circulation network.

For optimal operations, the mobility hub should provide dedicated entry/exits for transit vehicles and consider potential future application of articulated buses and autonomous shuttles/TNCs in its design. In addition, the mobility hub should be sited at a logical campus gateway, such as near the intersection of Nutwood Avenue and N. Commonwealth Avenue to serve a majority of external/internal campus connections and offer opportunities for enhanced placemaking. This location could be served by OCTA Routes 24 (future Route 123), 26 and a potential Downtown Fullerton Circulator.

Other potential mobility hub locations include State College Boulevard near existing OCTA Route 57/57X stops (or a relocated stop at Gymnasium Campus Drive closed to vehicle through traffic) and Yorba Linda Boulevard/N. Campus Drive near the existing OCTA Route 153 stop.

Figure 79. Mobility Hub





Figure 80. Mobility Hub Perspective





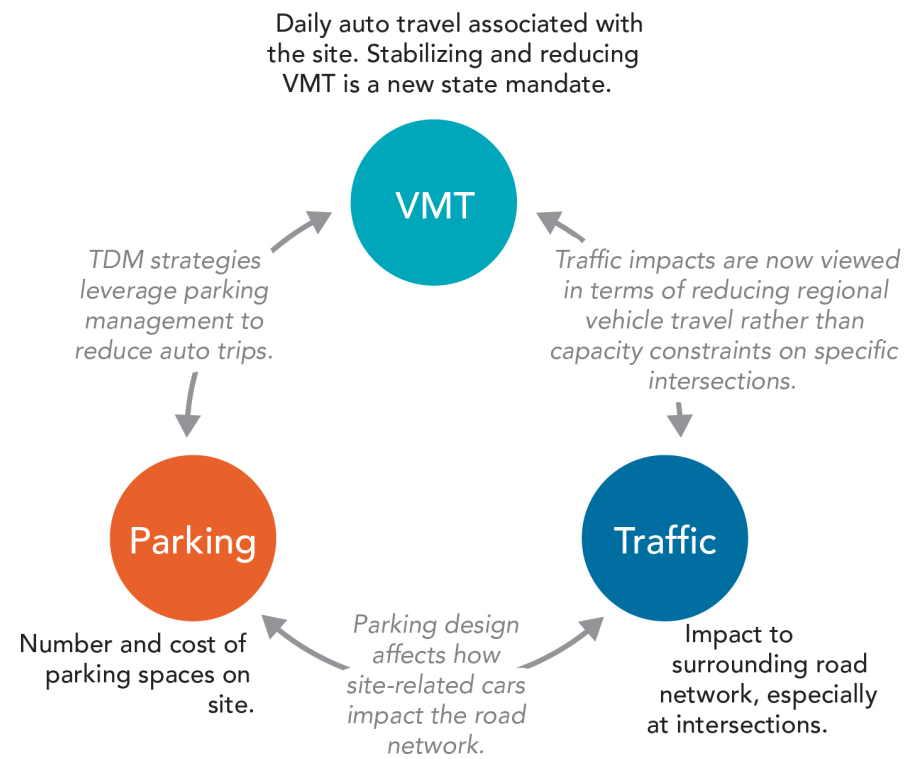
# TRANSPORTATION DEMAND MANAGEMENT

## PARKING OUTLOOK

Analysis of future parking demand for the Physical Master Plan future-build scenarios of 3,000 new on-campus housing beds would require approximately 813 additional net parking spaces at an estimated cost of \$16.2 million, with annual maintenance upwards of \$250,000. When accounting for the Physical Master Plan headcount growth of commuter students and faculty/staff, this figure grows considerably higher (4,473 spaces) if the University chooses to supply parking at rates that meet existing observed peak demands (see Table 13)<sup>1</sup>

By reducing existing and future parking demand through TDM measures, the amount of parking that will need to be constructed in the future can be reduced. By reducing demand for new parking supply, land can be utilized for higher value uses such as on-campus housing, academic and research facilities, and green infrastructure. Freeing up on-campus land for active uses is especially important in the context of Cal State Fullerton due to constraints that limit expansion beyond the existing footprint (established residential neighborhoods to the north and west and SR-57 to the east). This is in accordance with the CSU TDM Manual that states that “there is a high opportunity cost of using campus land for parking compared to active uses like academic facilities and housing.”

**Figure 81.** Typical Internal Street- Auto



For this Physical Master Plan, a variety of existing and potential TDM measures were evaluated for their potential to reduce campus parking demand attributed to future growth. Three scenarios – Light, Medium, and Robust TDM were developed with different levels of implementation and anticipated levels of use. Through multiple rounds of feedback from the University, the Medium TDM scenario was selected. This package accounts for continuation of existing

programs like Zipcar, enhancement of existing programs like web-based ride-matching for carpool/van-pools, and all new measures like a ban on first-year student residents bringing a car on campus. Table 13 provides peak parking demand per additional affiliates with implementation of the recommended Medium Term Implementation TDM Strategy package described on the following page<sup>2</sup>.

**Table 13.** Parking Supply

	Commuter Student	Resident Student	Faculty/Staff	Total
Existing Surface Supply	3,045	357	1,819	5,221
Existing Structure Supply	5,202	184	11	5,397
Existing Total Supply	8,247	541	1830	10,618
Future Total with New East Structure	-	-	-	11,695 <sup>3</sup>
Distribution of Total Supply	72%	5%	16%	-
Permit Purchase Ratio	0.51	0.42	0.9	-
Stall Turnover Ratio	2.06	1.29	1.45	-
Peak Demand per 1,000 additional affiliates	248 spaces	271 spaces	621 spaces	-

**Table 14.** Parking Demand<sup>4</sup>

2020 Baseline (2019 Needs Assessment deficit scenario)	Stall Demand
Phase 1: Projected Demand	829
Phase 2: Projected Demand	1,392
Phase 3: Projected Demand	1,983
Phase 4: Projected Demand	2,604

1. This assessment assumes a 1:1 replacement ratio for existing parking displaced by redevelopment projects, an assessed existing deficit of 600 spaces in 2020 after construction of the Eastside Deck, and provision of new supply to meet observed peak demand for students, faculty, and staff at CSUF if parking permit purchase and turnover rates remain similar to previous years.  
 2. TDM parking demand reductions are calculated from methodology developed by the California Air Pollution Control Officers Association (CAPCOA)

3. Assumes loss of stalls from Lot E and East Campus Drives  
 4. Note this scenario accounts for a campus deficit of 600 parking spaces, which is an adjustment of the 2019 Parking Needs Assessment following completion of the Eastside 2 parking structure.



## PHASED IMPLEMENTATION (

Cal State Fullerton is positioned to reduce parking and traffic demand, reduce transportation-related emissions, and comply with new vehicle miles traveled reduction goals of the CSU system by implementing an aggressive suite of TDM measures. If coordinated, these measures can also serve to boost the overall attractiveness of campus, and parking revenues can better support multi-modal programs and incentives.

Influencing travel behavior requires a portfolio of commuter alternatives and incentives that should go hand in hand with minimizing parking supply and implementing parking pricing strategies for maximum effectiveness. Some strategies can be implemented in the near-term to make progress toward reducing the rate of vehicle trips to campus, while others will require longer implementation horizons to lower parking demand from future growth. TDM strategies should be tailored to both the existing affiliates, and also the anticipated growth, to ensure that the University makes progress toward decoupling new affiliates from a need for new parking spaces and new traffic demand.

### SHORT TERM



#### First-year Parking Ban

By disallowing first year on-campus resident students from storing a private vehicle on campus, the university can immediately reduce parking demand associated with campus growth, also setting future behavior patterns in later years. This is best paired with an increase in multi-modal incentives and options.



#### Dynamic Shared Ride Matching

Platforms like Scoop, Luum, and RideAmigos are designed to connect and incentivize shared rides to work or school. Alternatively, open source alternatives like WazeCarpool can be advertised.



#### Increased Car Share Spaces and Incentives

As the student population grows, providing both increased number of premium car share spaces on campus, particularly near dorms, and also discounted or free membership (for services like ZipCar) in tandem is a well-documented effective strategy-particularly when paired with marketing of this service.



#### Enhanced Guaranteed Ride

A common hurdle for university employees to transition from driving and parking, to transit, as primary mode are the "what if" scenarios. Establishing a guaranteed ride home program whereby an employee can occasionally access an emergency ride home can help. Providing this service is only getting easier with the availability of TNCs.



#### Bike Theft Reduction Program

Theft discourages bike use, is commonly cited as hurdle for student ridership, and the issue could be improved by secure bike parking and a proactive theft prevent program operated by the university.

### MEDIUM TERM



#### Maintain Existing Transit Pass Subsidies

CSUF provides a significant student subsidy for OCTA transit passes and a fully funded pass for eligible employees. Maintaining this level of discount is vital to increasing transit ridership as levels of service and on campus population increase.



#### Fund and Implement Enhanced OCTA Circulator Bus Concept

The Master Plan process explored circulator requests between campus and downtown, ultimately recommending an overlay OCTA service during peak hours to improve service, with the campus stop moving on campus to improve visibility and reduce the need to cross Nutwood Avenue to catch the bus.



#### Pilot Mobility Hub Concept

Big ideas can be implemented in a shorter time horizon using temporary materials. Bringing OCTA service connecting to downtown onto campus, making more comfortable waiting areas, and creating TNC waiting areas can help better arrange access to bus service in a shorter time horizon – ahead of a long-term physical upgrade.



#### Pilot Closure of Section of Gymnasium Drive

To advance and test the concept of closing a portion of Gymnasium Drive to vehicles, temporary materials could be deployed in advance of long-term physical improvements.



#### Improved Multi-modal Wayfinding System

Wayfinding should emphasize transit, walking, and biking facilities, and generally make the campus more legible – even to visitors.



#### Expand Bike Benefit to Students

The University currently offers a \$2/day bike benefit to employees that forgo a parking permit. The University could expand this program by offering a monthly bicycle subsidy to cover common bicycle expense for students that do not park on campus.



#### Variable Parking Pricing

Rather than relying only on new supply to accommodate growth, pricing management is well-documented as an effective tool for reducing overall parking demand and increasingly availability.

### LONG TERM



#### Champion Physical Multi-modal Improvements Around and To and From Campus with Partner Agencies

Work with the City of Fullerton and OCTA to lobby for increased transit service and bike and safety improvements near and to campus.



#### Improve Nutwood Avenue Pedestrian Crossings and Implement Traffic Calming Measures

A series of safe, comfortable at-grade crossings is critical for increasing pedestrian access to and from campus.



#### Permanent Mobility Hub

Using permanent materials and learning from pilot phase use patterns, upgrade.



#### Permanent Pedestrian Street Upgrade to Gymnasium Drive

Building on lessons learned during pilot phase, implement refined street materials for pedestrian only section, using hierarchy and materials aligned with broader circulation hierarchy plan.





# Infrastructure

Coordinating infrastructure strategies across the campus will be integral in a successful plan. The following sections analyze the existing conditions, proposed demand under the Physical Master Plan, and recommendations for all campus infrastructure.

## CIVIL INFRASTRUCTURE

### SANITARY SEWER

#### *Existing Conditions*

The campus is adjacent to three public sanitary sewer mains: an 18-inch vitrified clay pipe (VCP) along Yorba Linda Boulevard, a 21-inch VCP along State College Boulevard, and a 10-inch VCP along East Nutwood Avenue. Sewage along Yorba Linda Boulevard and East Nutwood Avenue flows east towards State College Boulevard. From State College Boulevard sewage flows south. The 18-inch VCP along Yorba Linda Boulevard and the 21-inch VCP along North State College Boulevard is maintained by the Orange County Sanitation District (OCS). The 10-inch VCP along East Nutwood Avenue flows west and is maintained by the City of Fullerton. Additionally, the 10-inch VCP along East Nutwood Avenue is part of the 20-year prioritized capital improvement project based on the City of Fullerton Sewer Master Plan by RMC Water Environmental, Inc. dated October 2009. The East Nutwood Avenue sanitary sewer improvement consists of upsizing the line from 10-inch to 12-inch. Currently, the campus sanitary sewer system is serviced through the sanitary sewer mains along Yorba Linda Boulevard and State College Boulevard.

The sanitary sewer pipes in the center, southwest, and northeast portions of the campus are considered as high

risk which are highlighted in red as shown on Figure 83. Common issues in the above-mentioned area are root intrusion, pipe cracking, and increases in sewage level due to displacement in pipes. Under average demand daily conditions, the majority of the pipes are adequately functioning, but under peak daily conditions the pipes are more than 100-percent full.

#### *Proposed Sewer Demand*

As shown on Figure 84, to accommodate the proposed facilities on campus, several facilities will be demolished and replaced. The existing facilities that will be replaced are listed in the Existing Sewer Flow Table, Table 15. Based on Table 15 below, the existing buildings that will be demolished and replaced are approximately generating 207,150 gallons per day (GPD) of wastewater. The sewer flow (GPD) from the proposed facilities are summarized in the Proposed Facilities Table, Table 16. It was determined that there will be approximately 1,434,373 GPD of wastewater generated from the proposed facilities. Overall, there will be net increase of approximately 1,227,223 GPD of wastewater.

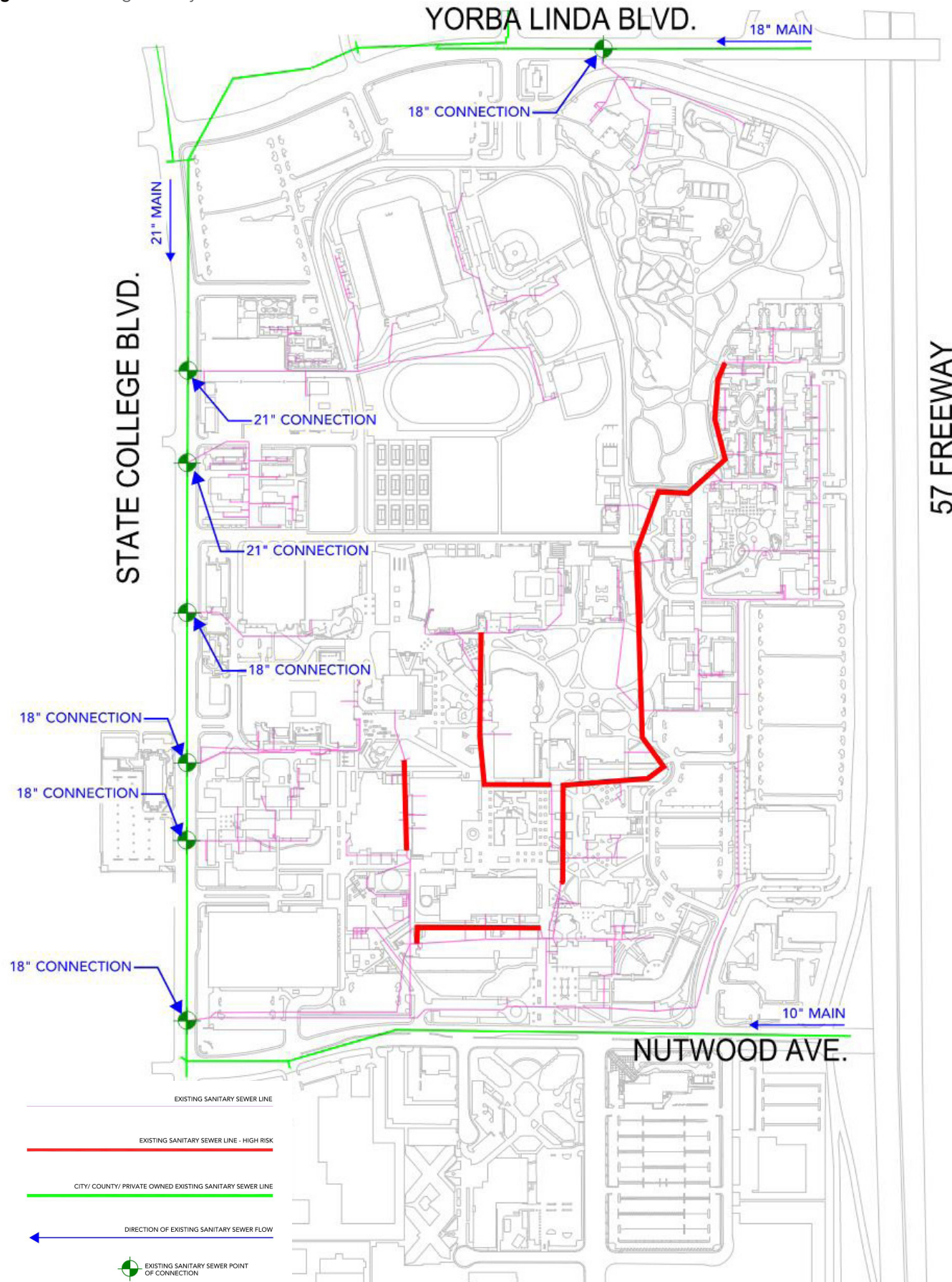
The proposed facilities were grouped for the sewer analysis, and certain critical pipes corresponding to these groups, as shown on Figure 84, were

assessed. The following sewer criteria laid out by the City of Fullerton was implemented: the allowable capacity for pipes under or equal to 12 inches in diameter can only flow at most at 50 percent full and for pipes 12 to 15 inches in diameter can only flow at most at 67 percent full. Capacity is based on the normal depth to diameter ratio. The proposed normal depths from the proposed facilities were determined through the program, Bentley FlowMaster V8i. Sewer calculations are shown in the Appendix. Per the grouped sewer analysis, the proposed facilities would require upsizing of the following sewer pipes: 2, 4, 5, 6 and 7, as summarized in the Pipe Sizing Recommendation Matrix. Sewer pipes 1 and 3 can adequately serve the proposed facilities.

These conclusions were made based on a couple assumptions. The proposed parking structures will not be generating any wastewater. Some of the proposed facilities in conflict with the existing campus sewer lines will be demolished and relocated, and a more detailed sewer analysis will be conducted for each proposed facility. The proposed GPD of wastewater is based on the Built-Form Program in Chapter 3 in this master plan. It is understood that the campus program is preliminary and is subject to change.



Figure 83. Existing Sanitary Sewer



**Recommendations**

As mentioned in the Existing Conditions, several sanitary sewer pipes are high risk due to root intrusion, pipe cracking, and increases in sewage level due to displacement. We recommend the removal and replacement of the pipes highlighted in red as shown in Figure 83 above. The sewer lateral connections for future developments should connect to the public sewer main along State College Boulevard until

the East Nutwood Avenue Capital Improvement Project is completed.

It was also determined that most of the campus sanitary sewer pipes are flowing at over 100 percent full under peak daily conditions. For this sewer analysis, the campus was divided into eight groups as shown on Figure 84, which correspond to eight downstream sewer pipes that will be servicing these groups. In order to properly accommodate the large GPD

increase of wastewater, as mentioned above, we recommend the upsizing of the following sewer pipes 2, 4, 5, 6 and 7. If the 10-inch VCP along East Nutwood Avenue CIP project is completed prior to the construction of Cluster 4, the sewer line servicing Cluster 4 should directly tap into the 10" VCP sewer main.

Table 15. Existing Sewer Flow from Facilities to be Replaced

Existing Building	SGF <sup>1</sup>	Quantity	SGF1	Sewer Flow (GPD)	Peak/Max Flow (GPD) (Peak Factor = 2.5)
Titan Bookstore	Store: Retail	41,777 SF	25 GPD/ 1,000 SF	1,044	2,611
Visual Arts B	Office Building	10,680 SF	120 GPD/ 1,000 SF	1,282	3,204
Visual Arts D	Office Building	37,445 SF	120 GPD/ 1,000 SF	4,493	11,234
Visual Arts E	Office Building	25,539 SF	120 GPD/ 1,000 SF	3,065	7,662
Engineering	Office Building	16,660 SF	120 GPD/ 1,000 SF	1,999	4,998
Education Classroom Building	Office Building	96,492 SF	120 GPD/ 1,000 SF	11,579	28,948
Jewel Plummer Cobb	Residential Dorm: College	600 Students	70 GPD/ Student	42,000	105,000
Health Sciences	Office Building	131,732 SF	120 GPD/ 1,000 SF	15,808	39,520
Maintenance Facilities	Warehouse	53,000 SF	30 GPD/ 1,000 SF	1,590	3,975
<b>Total</b>				<b>82,860</b>	<b>207,150</b>

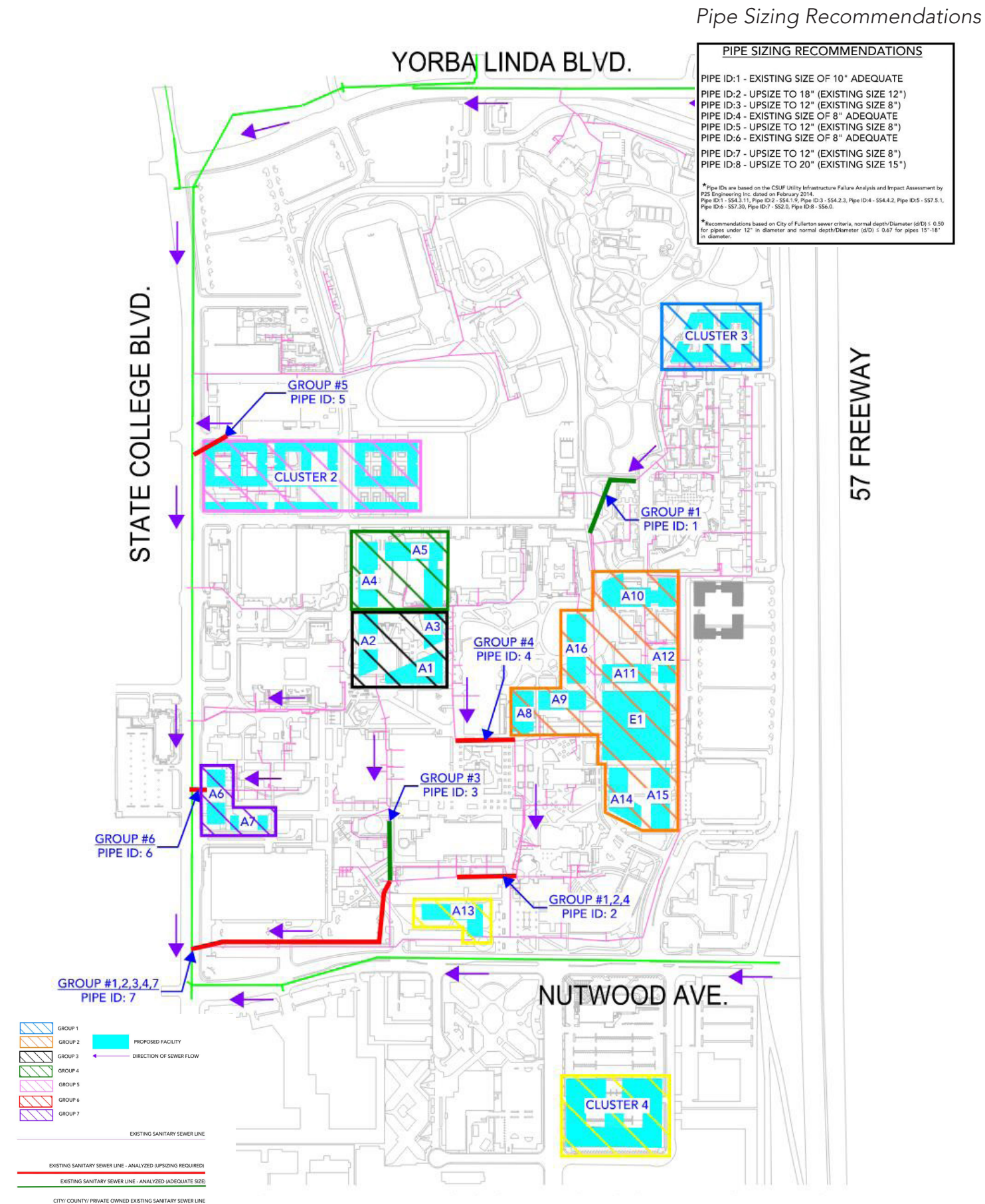
(1) Based on the City of Los Angeles "Sewerage Facilities Charge Sewage Generation Factor for Residential and Commercial Categories."



**Table 16.** Sewer Flow from Proposed Facilities

Group #	Proposed Building	Building Use	SGF Category	Quantity	SGF	Sewer Flow (GPD)	Peak/Max Flow (GPD) (Peak Factor = 2.5)
1	Cluster 3	Student Housing	Residential Dorm: College	600 Students	70 GPD/Student	42,000	105,000
	A8	Academics	Office Building	72,762 SF	120 GPD/1,000 SF	8,731	21,828
	A9	Academics	Office Building	84,000 SF	120 GPD/1,000 SF	10,080	25,200
	A10	Academics	Office Building	180,000SF	120 GPD/1,000 SF	21,600	54,000
	A11	Academics	Office Building	85,000 SF	120 GPD/1,000 SF	10,200	25,500
2	A12	Academics	Office Building	55,000 SF	120 GPD/1,000 SF	6,600	16,500
	A14	Academics	Office Building	120,000SF	120 GPD/1,000 SF	14,400	36,000
	A15	Academics	Office Building	120,000SF	120 GPD/1,000 SF	14,400	36,000
	A16	Academics	Office Building	126,000SF	120 GPD/1,000 SF	15,120	37,800
	E1	Event Center	Banquet Hall	254,100SF	350 GPD/1,000 SF	88,935	222,338
3	A1	Academics	Office Building	125,000SF	120 GPD/1,000 SF	15,000	37,500
	A2	Academics	Office Building	132,000SF	120 GPD/1,000 SF	15,840	39,600
	A3	Academics	Office Building	50,000 SF	120 GPD/1,000 SF	6,000	15,000
4	A4	Academics	Office Building	150,000SF	120 GPD/1,000 SF	18,000	45,000
	A5	Academics	Office Building	240,000SF	120 GPD/1,000 SF	28,800	72,000
5	Cluster 2	Student Housing	Residential Dorm: College	2,400 Students	70 GPD/Student	168,000	420,000
6	A6	Academics	Office Building	108,000SF	120 GPD/1,000 SF	12,960	32,400
	A7	Academics	Office Building	54,000 SF	120 GPD/1,000 SF	6,480	16,200
	A13	Academics	Office Building	52,528 SF	120 GPD/1,000 SF	6,303	15,758
7	Cluster 4	Faculty Housing	Residential Apt - 1 BDR	90 DU	110 GPD/DU	9,900	24,750
		Faculty Housing	Residential Apt - 2 BDR	175 DU	150 GPD/DU	26,250	65,625
		Faculty Housing	Residential Apt - 3 BDR	85 DU	190 GPD/DU	16,150	40,375
8	New Facilities in Arboretum	Student Facilities	Office Building	100,000SF	120 GPD/1,000 SF	12,000	30,000
<b>Total</b>						<b>573,749</b>	<b>1,434,373</b>

**Figure 84.** Grouped Sewer Analysis of Proposed Facilities





## STORM DRAINAGE AND LOW IMPACT DESIGN

### Existing Conditions

There are currently three storm drain hard pipe connections from the campus to the city mains. There is a 39-inch reinforced concrete (RCP) connection to the 42-inch RCP City of Fullerton storm drain main along State College Boulevard, a 15-inch RCP connection to the 18-inch RCP City of Fullerton storm drain main adjacent to the State College Boulevard and Yorba Linda Boulevard intersection, and a 33-inch RCP connection to the 33-inch RCP City of Fullerton storm drain main adjacent to State College Boulevard and East Nutwood Avenue intersection. Storm water is also conveyed out of the campus through several curb outlets along State College Boulevard.

As shown on Figure 85, all the private campus storm drain pipes are flowing under pressure and are flowing well over 100 percent full in an event of a two-year storm. There also many undersized pipes and inadequate pipe slopes. The athletic fields, the area north of the fine arts auditorium and the area west of the Pollack Library, are notable flood areas. It is stated in the 2010 CSUF Utility Master Plan by P2S Engineering, Inc. indicates that the City of Fullerton storm drain system is unable to handle the stormwater discharge from the campus as currently configured and sized. Moreover, the 2010 CSUF Utility Master Plan by P2S Engineering, Inc. indicates that the City of Fullerton's downstream receiving flood channels and infrastructure do not have capacity for additional flow from future campus improvements. Recent campus improvements such as the Student Housing Buildings west of the 57 Freeway are utilizing LID stormwater mitigation best

management practices (BMPs) that treat stormwater discharge on site and reduce stormwater volume runoff.

### Proposed Storm Drain Management

As mentioned in the section above, all the campus storm drain lines are flowing under pressure in an event of a two-year storm. Furthermore, the City of Fullerton is unable to handle additional discharge from the campus. In order to alleviate this issue, on site post construction Low Impact Design (LID) best management practices (BMPs) must be implemented. Structural BMPs mitigate the impacts of runoff and stormwater pollution as close to the source as possible. Based on the Orange County LID Technical Guidance Documents, BMPs are prioritized in order of design preference; the allowable BMP methods (in order of priority) are:

1. Infiltration Systems
2. Stormwater Capture and Use
3. High Efficiency Biofiltration/ Bioretention Systems

Deep and shallow infiltration systems were analyzed. From our understanding, deep infiltration seemed to be feasible for the following areas: A6 and A7. Shallow infiltration was analyzed in the other areas. Figure 86 shows the approximate deep and shallow infiltration system sizes. If infiltration is deemed infeasible, stormwater capture and use and bioretention/ bioswale systems should be explored. As shown on Figure 86, if a centralized capture and reuse system were to be utilized, it would approximately require 29 units of 10-foot diameter by 40-foot-long subterranean tanks.

Alternatively, if bioretention basins and bioswales systems were used, it would require multiple treating areas to accommodate the future developments, as shown on Figure 88. Furthermore, it has been determined that Clusters 3-4 and Areas 6-16, can either implement bioretention basins or a bioswales. Due to area constraints, Cluster 2 and Areas 1-5 only allow room for bioretention basins. The approximate required bioretention basin and bioswale areas are summarized in Figure 86. Figure 87 below show what typical deep/shallow infiltration, capture and use, bioretention basins, and bioswales systems look like. A combination of the above-mentioned allowable BMP methods can also be utilized.

### Recommendations

Due to the limitations of the campus and City storm drain lines, it is recommended that any new proposed facilities implement LID BMPs that strive to produce zero stormwater runoff from at least a two-year storm event.

Figure 85. Existing Storm Drain

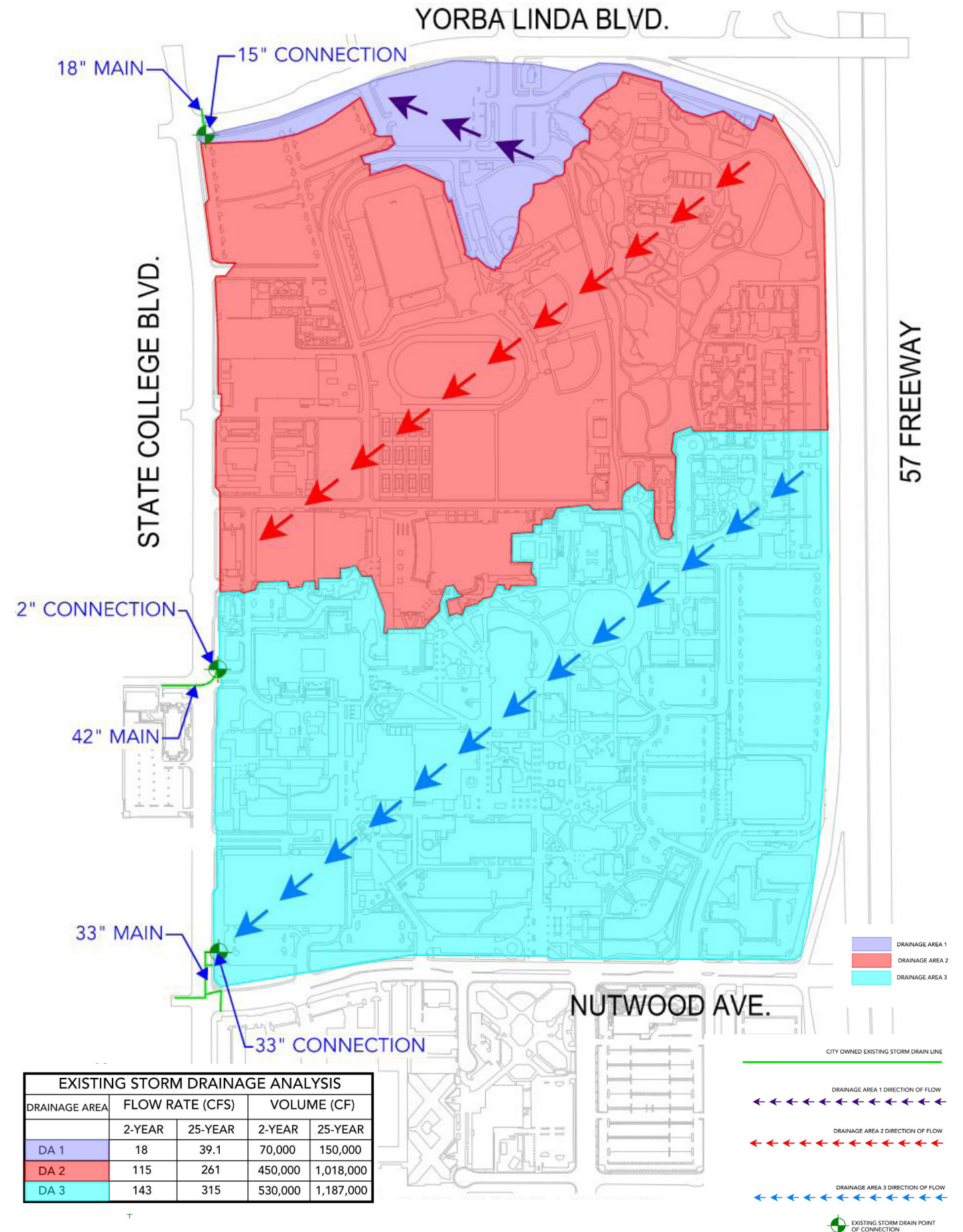




Figure 86. Centralized Low Impact Design Strategy (Capture and Reuse)

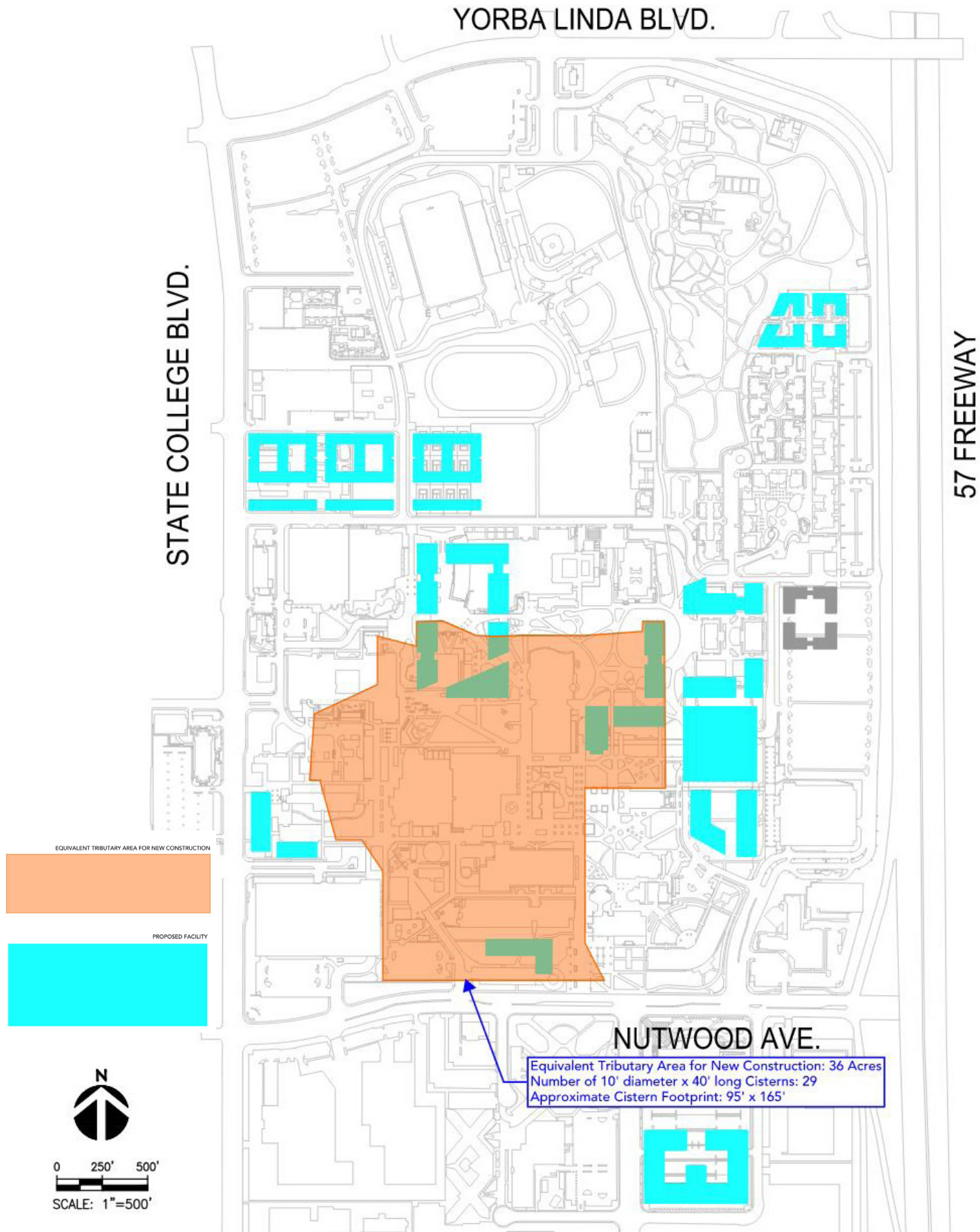
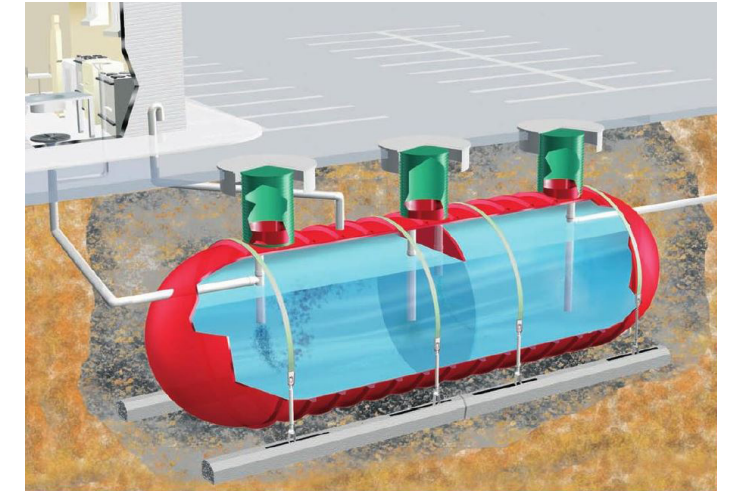


Figure 87. Storm Drain Management Examples  
Bioretention



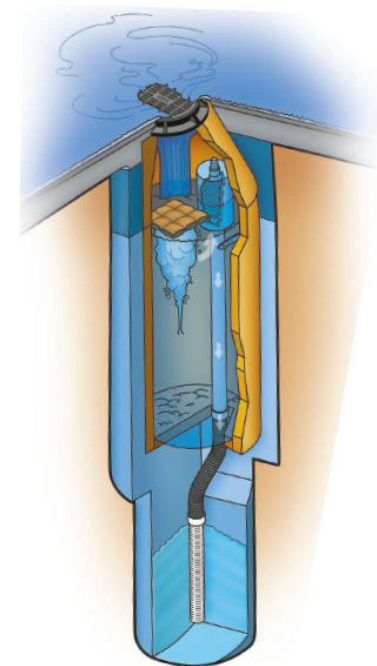
KPFF Photo Library

Detention (Capture + Use)



Source: XERXES, ZCL.COM

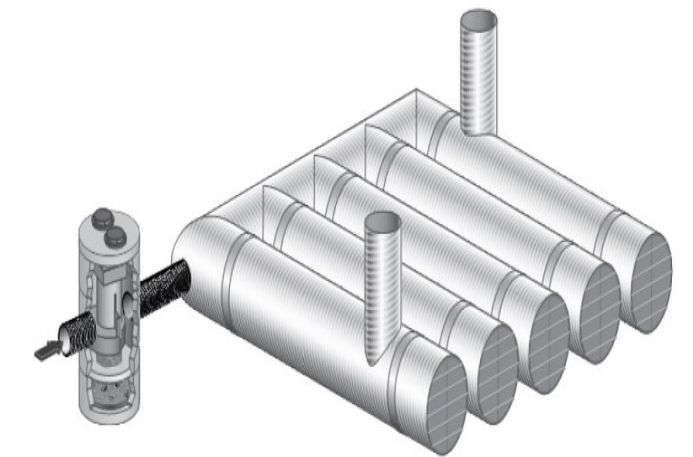
Deep Infiltration



SOURCE: TORRENT RESOURCES, TORRENTRESOURCES.COM

Source: Torrent Resources

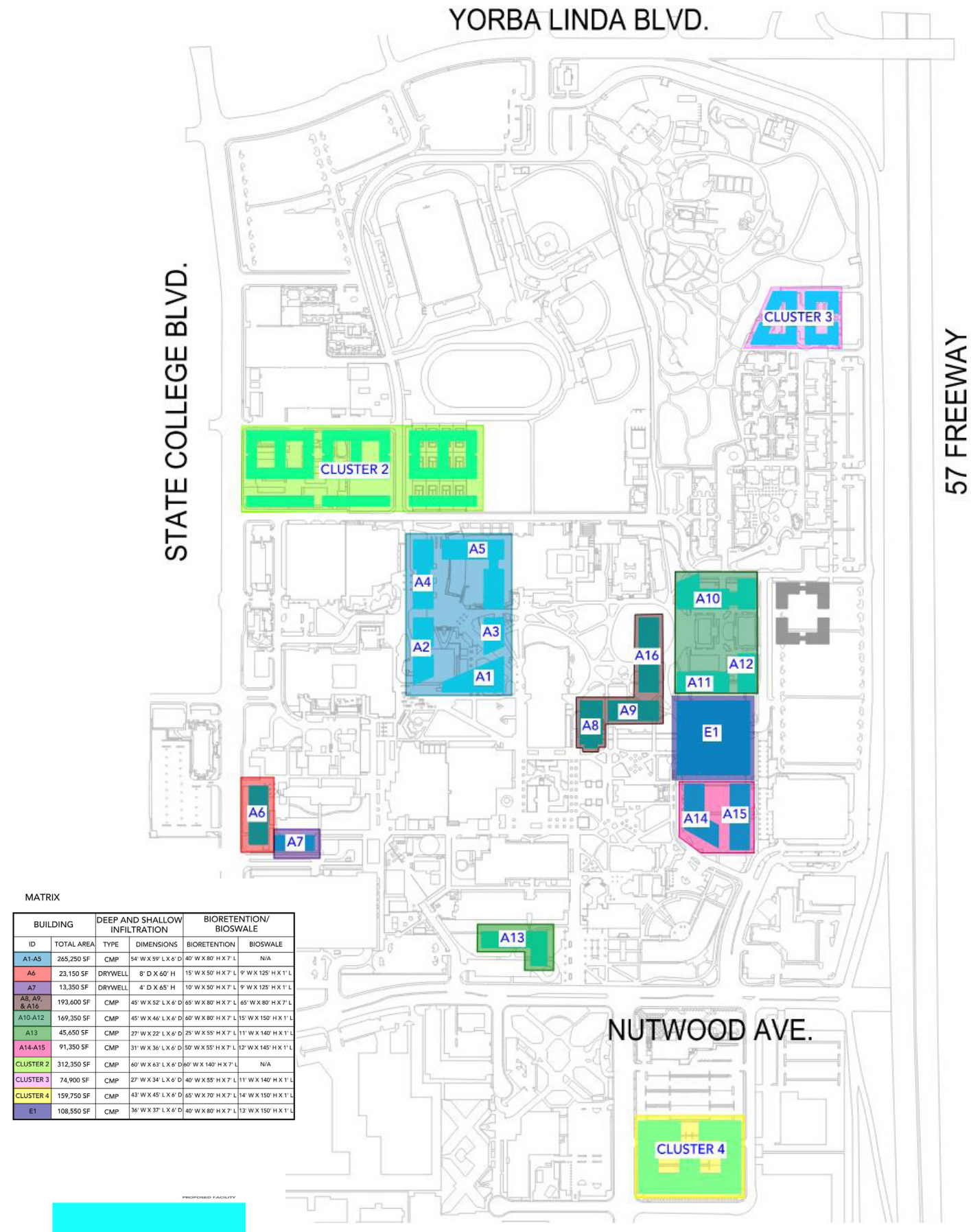
Shallow Infiltration



Source:Contech, Conteches.com



Figure 88. Localized Low Impact Design Strategy



MATRIX

BUILDING		DEEP AND SHALLOW INFILTRATION		BIORETENTION/BIOSWALE	
ID	TOTAL AREA	TYPE	DIMENSIONS	BIORETENTION	BIOSWALE
A1-A5	265,250 SF	CMP	54' W X 59' L X 6' D	40' W X 80' H X 7' L	N/A
A6	23,150 SF	DRYWELL	8' D X 60' H	15' W X 50' H X 7' L	9' W X 125' H X 1' L
A7	13,350 SF	DRYWELL	4' D X 65' H	10' W X 50' H X 7' L	9' W X 125' H X 1' L
A8, A9, & A16	193,600 SF	CMP	45' W X 52' L X 6' D	45' W X 50' H X 7' L	65' W X 80' H X 7' L
A10-A12	169,350 SF	CMP	45' W X 46' L X 6' D	40' W X 80' H X 7' L	15' W X 150' H X 1' L
A13	45,650 SF	CMP	27' W X 22' L X 6' D	25' W X 55' H X 7' L	11' W X 140' H X 1' L
A14-A15	91,350 SF	CMP	31' W X 36' L X 6' D	50' W X 55' H X 7' L	12' W X 145' H X 1' L
CLUSTER 2	312,350 SF	CMP	60' W X 63' L X 6' D	40' W X 140' H X 7' L	N/A
CLUSTER 3	74,900 SF	CMP	27' W X 34' L X 6' D	40' W X 55' H X 7' L	11' W X 140' H X 1' L
CLUSTER 4	159,750 SF	CMP	43' W X 45' L X 6' D	45' W X 70' H X 7' L	14' W X 150' H X 1' L
E1	108,550 SF	CMP	36' W X 37' L X 6' D	40' W X 80' H X 7' L	13' W X 150' H X 1' L

## FIRE AND DOMESTIC WATER

### Existing Conditions

The campus is adjacent to three City of Fullerton maintained water mains: a 16-inch steel cylinder concrete pipe (SCCP) along Yorba Linda Boulevard, a 12-inch cast iron pipe (CIP) along State College Boulevard, and a 12-inch CIP along East Nutwood Avenue. The campus' water and fire water demands are serviced through a 10-inch water lateral connecting to the 16-inch SCCC main along Yorba Linda Boulevard, a 12-inch water lateral connecting to the 12-inch CIP along East Nutwood Avenue, and the two 12-inch water laterals connecting to the 12-inch CIP main along State College Boulevard.

The campus currently has a combined firewater and domestic water system. Several high-risk pipes are made of asbestos material. Table 17 below shows the results of the hydrant flow tests that were received for three City of Fullerton water mains at locations where the campus system connects. These flows were used as inputs in the hydraulic model to determine adequacy of the campus network.

### Proposed Fire Demand

The proposed master plan scheme will include a number of new buildings as outlined in the sewer section above. These new buildings will require fire flow demand based on the 2016 California Fire Code. The table below indicates the required fire flow for each of the new buildings per this master plan. These fire flow demands assume a conservative construction type V.

A fire flow analysis was performed using the fire flow demands in the table above to determine if the existing system would be sufficient for the future demands. To run the fire flow analysis in the hydraulic model, the campus fire water network was grouped into clusters based on proximity and available water mains. The largest fire flow within each cluster was then analyzed and the associated water system flows and pressures were determined. Due to the scale of the campus and the nature of the master plan, the model level of detail was limited to main water lines and excluded smaller laterals and hydrants. A summary of the results of this analysis can be found in the table below and the detailed results can be found in the Appendix. Cluster 4 was excluded from the model under the assumption that water service for these buildings would connect directly to the City of Fullerton water network.

### Recommendations

The fire flow analysis described in the section above indicates that the existing combined water system has capacity to support the future buildings; however, there are some deficiencies that should be improved. As can be seen in the Fire Flow Analysis Results table, all of the groups achieved the desired fire flow apart from Group 7. This cluster may need booster pumps inside the building. Moreover, both of these buildings would benefit from the introduction of a dedicated fire water loop for the campus. A looped system adds redundancy to the system in case of repairs or shutdowns and a dedicated fire water system will provide additional capacity in both domestic and fire water systems. The proposed fire water loop can be seen in the map on the following page. As mentioned in the Existing Conditions section, many of the pipes on the campus are made of asbestos which is unsafe and no longer common practice. We understand that the campus facilities have been replacing this material when pipes break; however, we recommend replacing all asbestos pipes in advance of failure. These recommendations are in addition to the recommendations described in the 2010 Utility Infrastructure Master Plan by P2S Engineering, Inc.

Table 17. Existing Flow from Public Water Mains

Street	Water Main Size	Fire Flow (GPM)	Static Pressure (PSI)
Nutwood Blvd.	12"	3,700	70
State College Blvd.	12"	4,600	76
Yorba Linda Blvd.	16"	3,600	64



Figure 89. Existing Water

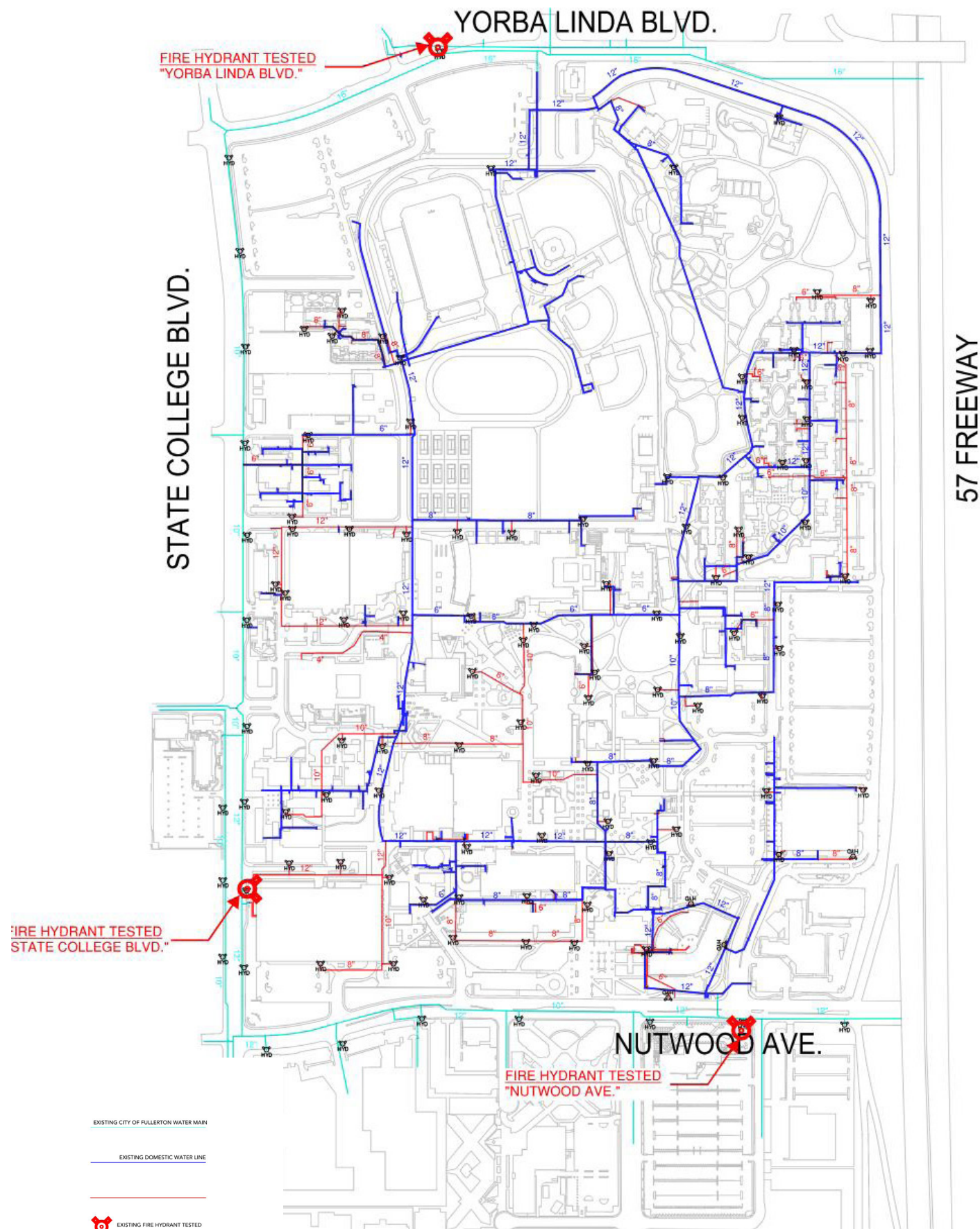


Table 18. Proposed Building Fire Flow Requirements

Group #	Building	Fire Flow Area (SF)	Fire Flow (GPD)
1	Cluster 3	185,420	4,000
2	Cluster 1	177,960	4,000
3	E1	276,171	4,000
	A8	85,360	4,000
	A9	99,648	4,000
	A10	177,960	4,000
	A11	102,264	4,000
	A12	67,020	3,500
	A14	129,600	4,000
4	A15	129,600	4,000
	A16	126,000	4,000
5	A13	149,160	4,000
	A1	115,080	4,000
6 & 7	A2	123,672	4,000
	A3	68,352	3,500
	A4	126,300	4,000
Other <sup>1</sup>	A5	198,000	4,000
	Cluster 2	910,000	4,000
Other <sup>1</sup>	A6	108,000	4,000
	A7	53,398	3,250
	Cluster 4	540,000	4,000

(1) "Other" Groups are assumed to currently have sufficient fire flow

Table 19. Fire Flow Analysis Results

Group #	Model ID	Fire Flow Required (GPM)	Fire Flow Available (GPM)	Minimum Pressure Required (PSI)	Calculated Pressure (PSI)
1	J-63	4,000	4,500	20	31
2	J-158	4,000	3,949	20	20
3	J-187	4,000	4,500	20	32
4	J-87	4,000	4,223	20	20
5	J-148	4,000	4,222	20	20
6	J-202	4,000	4,500	20	38
7	J-23	4,000	3,710	20	20

Fire Flow Analysis did not take into account individual hydrants or hydrant laterals.



Figure 90. Fire Flow Analysis Clusters

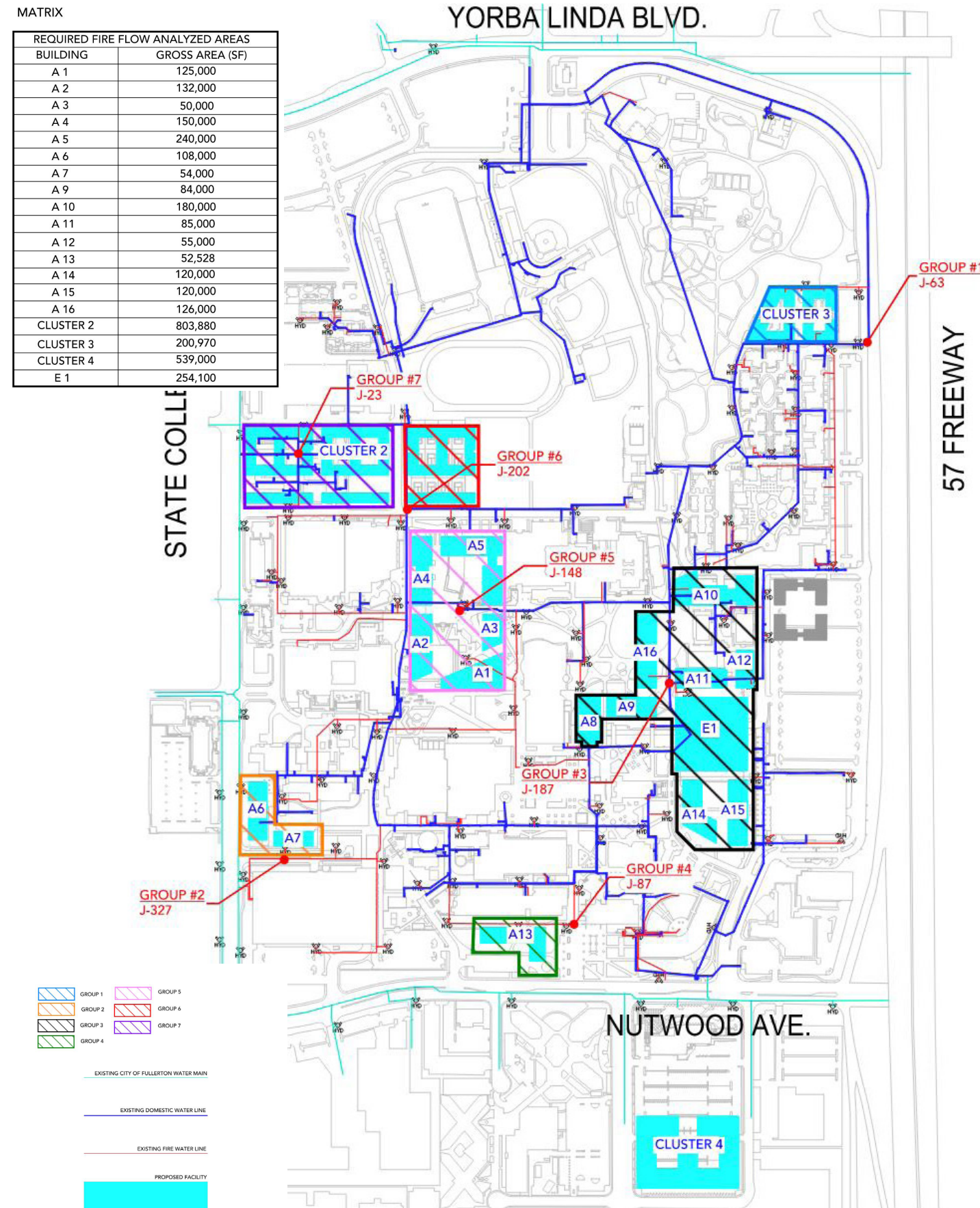
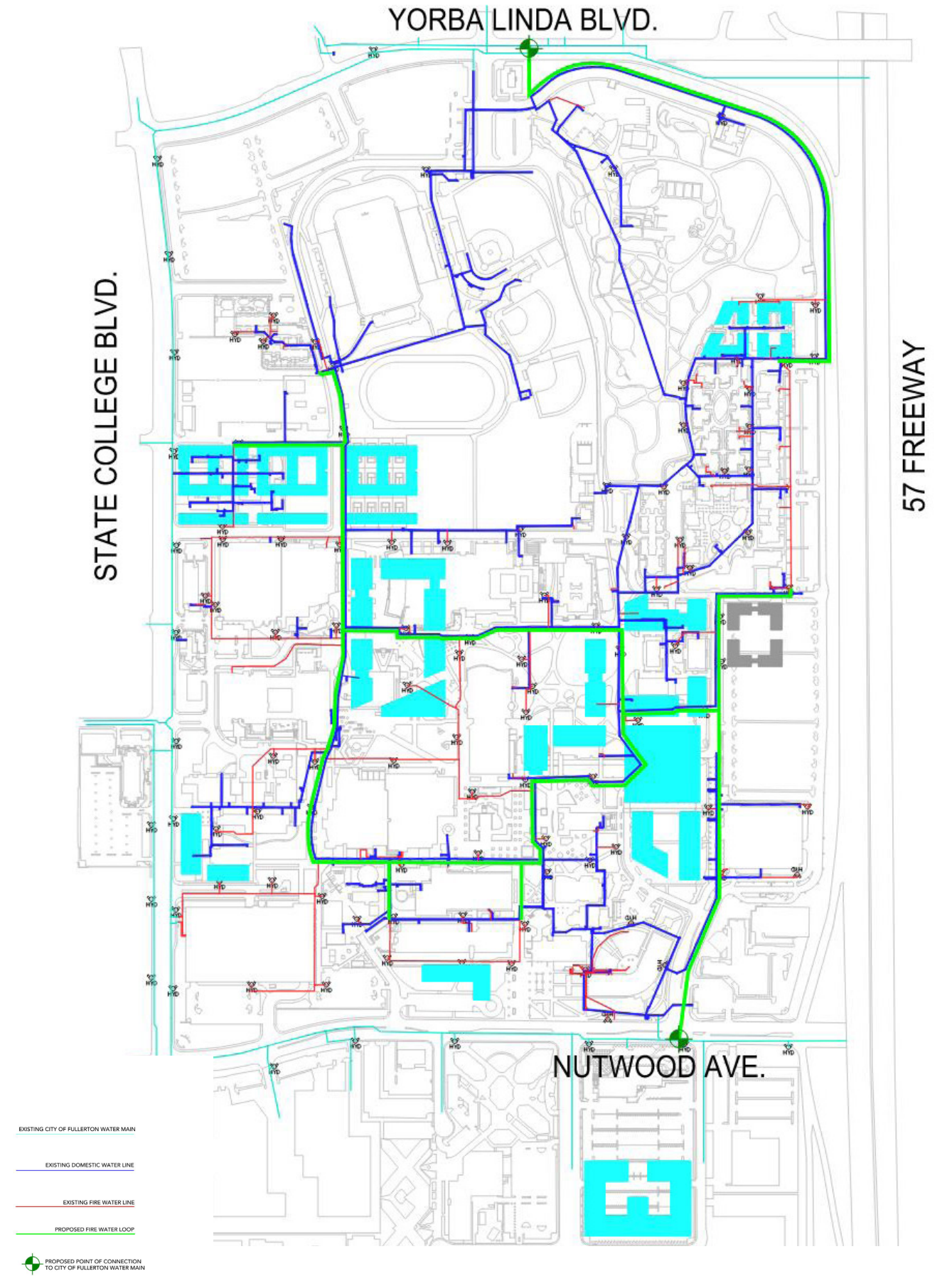


Figure 91. Fire Water Loop





# UTILITIES / MECHANICAL, ELECTRICAL, AND PLUMBING

## MECHANICAL SYSTEMS

### Existing Conditions

#### Central Cooling Plants

Based on the Utility Infrastructure Failure Analysis and Impact Assessment report dated February 24, 2014, the majority of the cooling and heating needs for the campus are currently met by two (2) central utility plants (CUP), providing chilled water (CHW) and heating hot water (HHW) to a common distribution loop which feeds the majority of the buildings on campus. The remainder of the campus buildings have independent HVAC systems. The two (2) CUPs serving approximately 2.5 million (M) gross square feet (GSF) of building space are listed below –

1. Main Central Plant (1992) – McCarthy Hall
2. Tri-Generation Plant (2008) – Adjacent of McCarthy Hall

There are two (2) thermal energy storage (TES) tanks that assist the campus in generating and storing CHW and HHW during the off-peak periods –

1. CHW TES Tank – 2.53M Gallons
2. HHW TES Tank – 466 Thousand Gallons

The main central plant has three (3) water cooled chillers and one (1) heat recovery chiller. Total capacity of these four (4) chillers are 4,300 tons. Based on ASHRAE Equipment Life Expectancy, all of these four (4) chillers are at the end of their useful life and **should be replaced**. There is a vacant bay available for a new chiller in this chiller plant. The Trigeneration plant has two (2) absorption chillers with total cooling capacity of 2,200 tons.

The main central plant is primarily used as a back-up system to the Tri-Generation plant for CHW. Based on the 2014 report, current peak cooling load of the buildings served by the two (2) CUPs are 4,900 tons. The 2.53M Gallon CHW TES Tank has cooling capacity of 28,000 ton-hours, which can store CHW required for almost 6 hours of campus cooling.

The CHW and HHW from the two (2) CUPs are distributed through main piping in utility tunnels (80%) and branch piping that are direct buried underground or in utilidor (20%). The 40-50 year old CHW and HHW distribution piping are experiencing leakage at various sections of the campus and **should be replaced**. The existing distribution systems do not have adequate isolation valves.

1. CHW Distribution – Two (2)-pipe system
2. HHW Distribution – Combination of two (2)-pipe, three (3)-pipe and four (4)-pipe system

Each CUP has independent primary CHW pumps and shared secondary CHW distribution pumps. The secondary distribution CHW pumps are not able to meet the hydraulic demand during peak cooling.

There are three (3) architectural cooling towers and six (6) condenser water pumps serving the two (2) CUPs. The condenser water system has controls issues which has resulted in ruptured lines.

#### Central Heating Plants

The campus high temperature HHW system was converted to low temperature HHW system in 2008. The two (2) absorption chillers from the Tri-generation plant have heating capacity of total 24,400 MBH. The heat recovery chiller in the main central plant has heating capacity of 18,800 MBH. This heat recovery chiller is at the end of its useful life as mentioned before and **should be replaced**.

The main central plant is primarily used as a back-up system to the Tri-Generation plant for HHW. Based on the 2014 report, current peak heating load of the buildings served by the two (2) CUPs are 31,000 MBH. Domestic hot water is produced at the building level by utilizing the HHW from the CUPs. Current peak domestic hot water load of the buildings served by the CUPs are 5,300 MBH. The 466K Gallon HHW TES Tank has heating capacity of 128,000 kBTU, which can store HHW required for about 3.5 hours of campus heating (space heating and domestic).

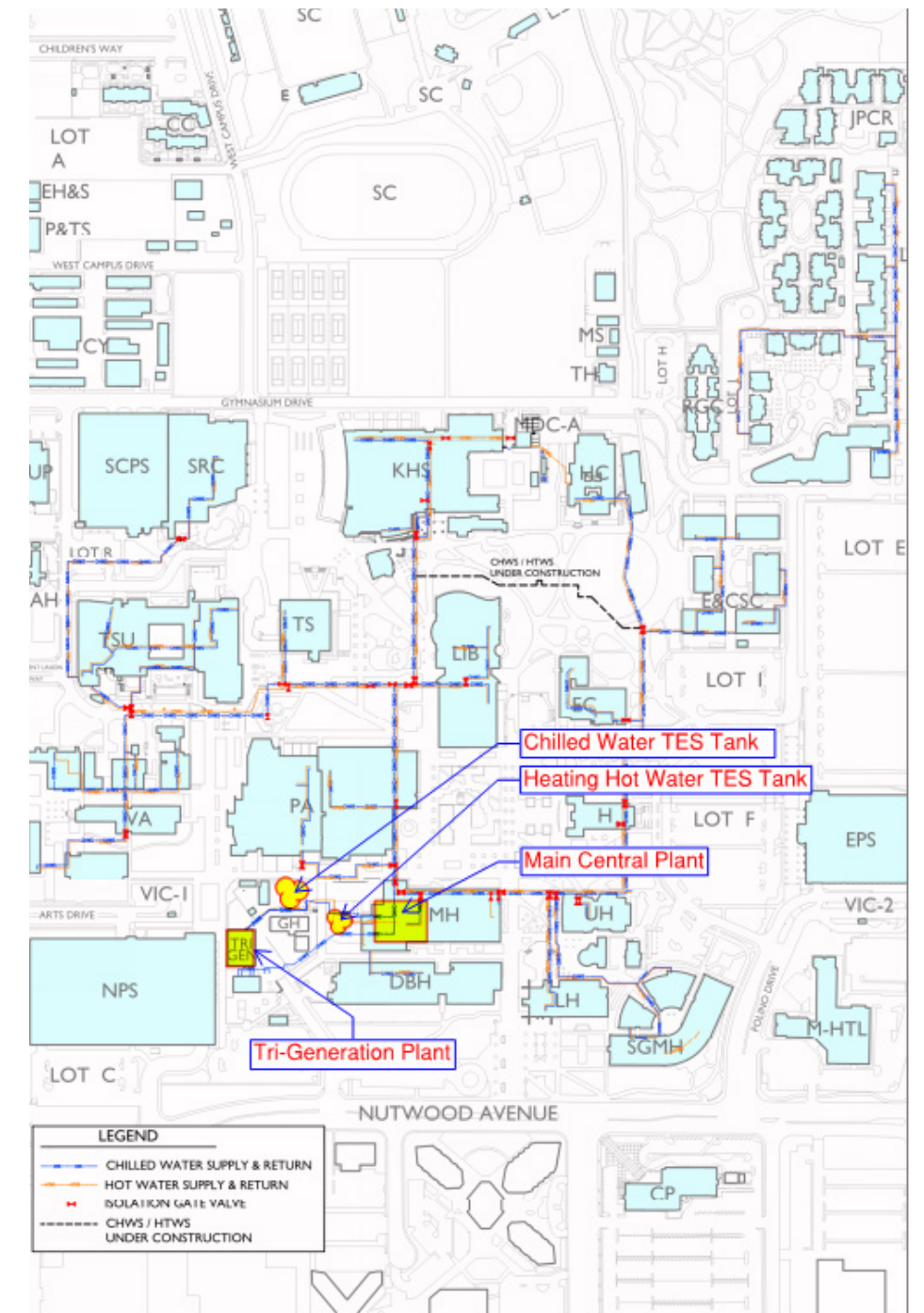
Each CUP has independent primary HHW pumps and shared secondary HHW distribution pumps. The secondary distribution CHW pumps are not able to meet the hydraulic demand during peak cooling.

### Independent Cooling and Heating Plants

The following is a brief overview of the independent cooling and heating plants in various buildings on campus; all of these systems are in good working condition based on the 2014 report –

1. Three (3) steam boilers – Laboratories in McCarthy Hall and Dan Black Hall (Total capacity: 3,225 MBH)
2. One (1) 80-ton air cooled Chiller – Data Center in Library (Backup)
3. Two (2) 300-ton air cooled chillers – Titan Student Union (Campus CHW lines for Backup)
4. Two (2) 2000 MBH Boilers – Titan Student Union (Campus HHW lines for Backup)
5. Two (2) 400-ton water cooled Chillers – Housing Phase 3
6. Four (4) 1,590 MBH Boilers – Housing Phase 3

Figure 92. Existing Chilled Water and Heating Hot Water System





## Proposed Demand

Based on the CPDC Presentation dated September 5th, 2019, there will be an addition of the following building types for future program.

Building Type	Gross Area (GSF)
Academic Student Life	1,781,526
Housing	1,342,880
Innovation Center	72,762
Event Center/Retail	294,100

Among the buildings that will be replaced, the following are the primary buildings currently connected to the existing CUPs .

Buildings to be Removed	Gross Area (GSF)
Health Science	212,868
Titan Book Store	41,777
Education Classroom	96,492

The existing (2) CUPs will not have enough capacity to meet the cooling and heating loads of future program. For all new future buildings types except housing, additional 2,800 tons of cooling capacity and 45,300 MBH of heating capacity are required.

Table 20 and Table 21 show the breakdown of total cooling and heating demands. Refer to Appendix-Central Utility Plant Loads for detailed Mechanical System load calculations.

## Recommendations

- Below are a list of options on how to meet the future demands.

### Academic/Student Life

Expansion of CUP is recommended to meet the cooling needs of future Academic buildings –

- Provide Heat Recovery Chiller(s) – *This option meets sustainability goals and provides simultaneous heating and cooling.*
- Provide (2) Electric Chillers to meet the demand of future academic buildings, Innovation Center and Event Center. Housing buildings to have independent HVAC system.
- Provide (1) Electric Chiller and independent HVAC systems – (1) water cooled Chiller in the existing vacant bay in McCarthy Hall to meet the cooling demands of future academic buildings; Innovation & Event Centers and Housing buildings to have independent HVAC system.

Expansion of CUP is recommended to meet the heating needs of future Academic buildings –

- Provide Heat Recovery Chillers – *This option meets sustainability goals and provides simultaneous heating and cooling.*
- Provide Electric boilers – *Close attention needs to paid to demand charges for this option; campus may be able to offset demand charges by charging HHW TES Tank during off-peak and mid-peak periods.*
- Provide gas-fired boilers – *This option uses fossil fuel and does not meet sustainability goals.*

### Housing

Independent HVAC systems are recommended to meet the cooling and heating needs of the future housing buildings.

- Independent CHW and HHW Plants
- Variable Refrigerant Flow (VRF) Heat Recovery System

**Table 20.** Proposed Cooling Load

Building Type	Gross Area (GSF)	Diversified Load Factor (SF/Ton)	Total Peak Load (Tons)
Academic/Student Life	1,781,526	438	4,064
Housing*	0	522	0
Innovation Center	72,762	382	191
Event Center/Retail	294,100	346	850
Total	2,148,388	Total	5,104
<b>Required Capacity</b>			<b>2,800</b>

**Table 21.** Proposed Heating Load

Building Type	Gross Area (GSF)	Diversified Load Factor (SF/Ton)	Total Peak Load (Tons)
Academic/Student Life	1,781,526	27	47,745
Housing*	0	20	0
Innovation Center	72,762	60	4,329
Event Center/Retail	294,100	34	9,852
Total	2,148,388	Total	61,927
<b>Required Capacity</b>			<b>45,300</b>

\*Housing will have independent HVAC, not taken into account for CUP Sizing Commercial Categories”

## ELECTRICAL SYSTEM

### Existing Conditions

Cal State Fullerton is currently served from a 66kV transmission line off of State College Boulevard from Southern California Edison (SCE). The transmission line serves a 66kV substation located on the southwest side of the campus. The substation is comprised of two, campus-owned, 10MVA transformers that step down the voltage from 66kV-12kV to serve the campus 12kV distribution system. Cal State Fullerton owns, operates and maintains the 66kV-12kV transformers and the responsibility for the 12kV distribution system. The 12kV system is fed from the 1200 ampere main campus switchgear. From the campus main 12kV switchgear, primary-selective 12kV circuits are distributed throughout the campus via underground manholes and conduits. The central plant chillers and boilers are fed with 4160 volts from two 3750 kVA transformers located in the main campus substation yard. The campus owns and maintains all of these facilities.

The campus buildings are currently served from a 12kV, 1200A, double ended main switchgear comprised of (10) 600A feeder breakers. The campus main 12kV distribution system is primarily comprised of 15kV cables installed in concrete-encased duct banks that traverse through conduits and manholes to serve 15kV selector switches located on campus. Main 15kV feeders originating from the main switchgear are 500kcmil EPR conductors and then reduce to 350kcmil and 4/0 EPR conductors as they traverse to the buildings. Radial feeders originating from the campus selector switches are sized to individual building loads and serve each building’s substation. Life

expectancy of this equipment can be estimated at 35 years, or up to the year 2031.

Campus standby generators serve building emergency loads. There are (20) identified generators installed before 2001 that currently do not meet the South Coast Air Quality Management District (SCAQMD) Rule 1470 Requirements for Stationary Diesel-Fueled Internal Combustion and other Compression Ignition Engines. Refer to Table 2 in the Appendix for list of identified generators and buildings served.

### Proposed

As part of future campus planning, an analysis of the current 12 kV distribution system was conducted to evaluate the existing spare capacity available at the main substation, the impact of the proposed buildings on the existing distribution system, and modifications required to support the future build out of the campus.

A review of the existing demand listed in Table 1 in the Appendix and the new program projected electrical demand revealed that the 12 kV double ended main switchgear is not adequately sized to meet the demands of the existing and future facilities. The campus has a total peak demand of 11.5 MVA and is expected to grow to 18.6 MVA with the additional demand of the future facilities. The future estimate is calculated based on standard industry watts/ft2 without designs for these facilities. This estimate also includes the addition of 300 electric vehicle (EV) charging stations that will be added to the electrical system throughout the campus. The anticipated electrical loads do not

include conversion of gas boilers to electric boilers as described elsewhere in the Physical Master Plan.

The power transformers located in the 66 kV substation with a rating of 10/12.5/14 MVA have a combined peak demand of 11.5 MVA. The substation is designed to allow the campus to continue to operate without impact to the day-to-day operations in the event of a single transformer failure. Due to the planned campus facilities growth, the projected electrical demand will increase by over 7 MVA once all planned facilities are operational. Therefore the 66 kV substation will have a peak load of approximately 18.6 MVA, exceeding the capacity of a single transformer feeding the campus.

SCAQMD Rule 1470 states that stationary compression engines with a brake horsepower greater than 50 and installed prior to 2001 must be replaced. Rule 1470 requires compliance with 100 percent of campus existing generators by January 1, 2009. As part of the campus electrical system upgrades, the (20) identified campus standby generators installed before 2001 should be upgraded to meet the SCAQMD Rule 1470.

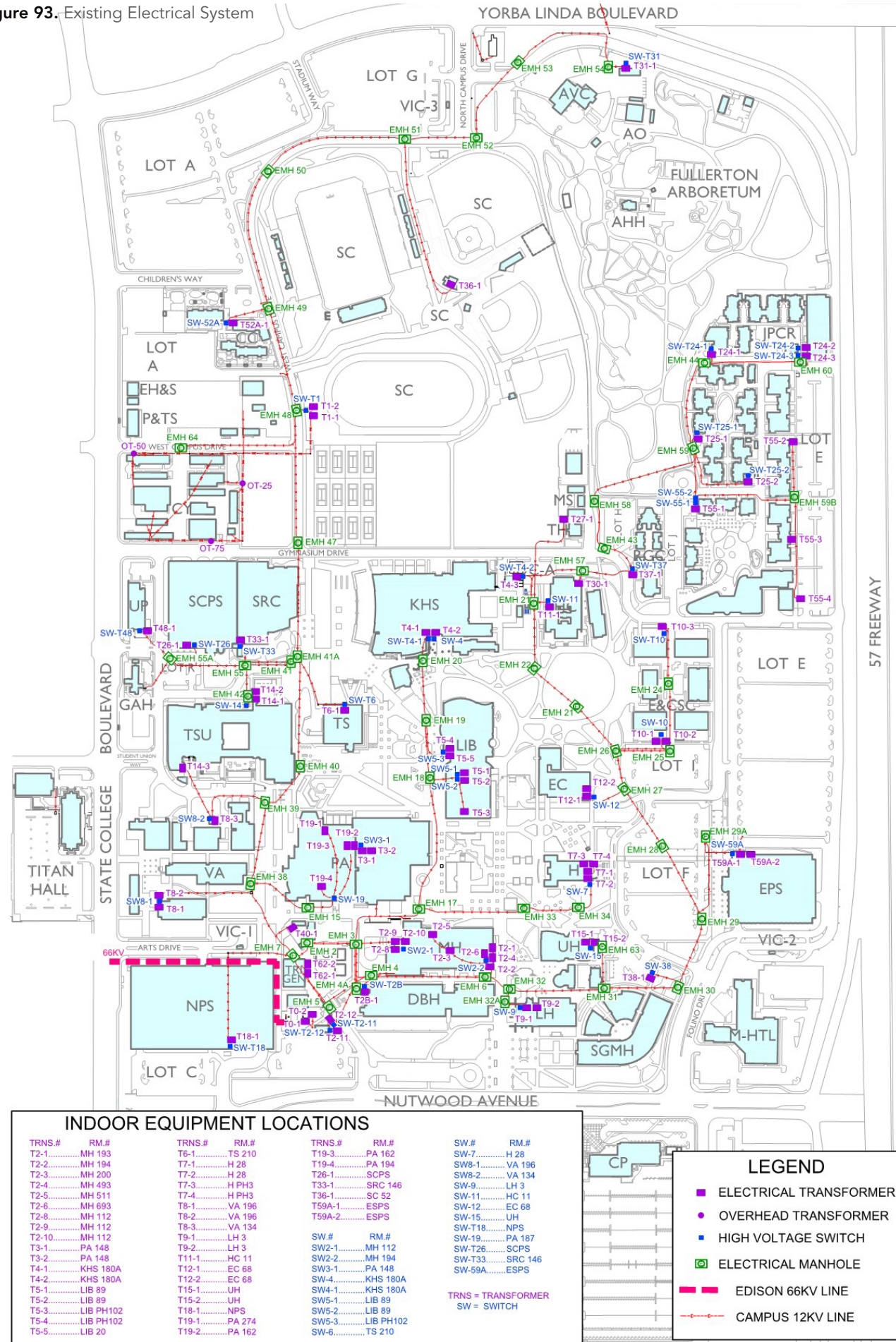
### Recommendations

In order to meet the infrastructure requirements for 32,000 FTES, the following electrical upgrades should take place:

- Replace the utility yard 10 MVA main campus transformers with 20 MVA units including secondary feeder modifications. The upgrade should occur before the peak demand of the system exceeds



Figure 93. Existing Electrical System



the maximum 14 MVA rating of the transformers to prevent the demand from exceeding the capacity of a single transformer. Exceeding the capacity of a single transformer eliminates the redundancy of the distribution system and will result in power service interruption in the case of faults and maintenance efforts. To avoid impacting day-to-day operations of the campus, only one transformer shall be replaced at a time and fully tested and verified before replacing the other. Replacement does not affect the existing switchgear which has adequate capacity for the additional demand and the transformer upgrades.

- Upgrade the (20) identified campus standby generators installed before 2001 to meet the SCAQMD Rule 1470.
- Substations in the Greenhouse Facilities, Titan Student Union, Sports Complex, and Nextel Site substations should be upgraded to primary selector switch to match the campus standard and to provide redundancy and capability of maintenance without power service interruption.
- The upgrade of existing underground ductbanks are phased as follows:

- ▷ To accommodate the increased demand of the new facilities on the southeast side of campus, a new double feeder and ductbank should be installed for the electrical connection to the new buildings on the southeast side of campus and existing buildings currently served by existing ductbanks that will be severed by the construction of new buildings.
- ▷ The existing switchgear should be upgraded to support two new feeders, one on each side of the tie breaker to support the

Table 22. New Program Projected Electrical Demand in KW

Space Type	GSF	VA/SF	kVA
New Student Housing	803,880	2	1,608
New Campus Amenities	800,000	3	2,400
New Faculty Housing	539,000	3	1,617
New Academic Space	881,526	5	4,408
New Non-Academic Space	40,000	2	80
New Innovation Center	72,762	4	291
New Facilities in Arboretum	100,000	2	200
New Event Center	254,100	5	1,271
Transportation Hubs	7,200	2	14
New Parking Structure	1,677,375	1	1,677
Corporation Yard	-	-	225
EV Chargers	x300	-	1,000
Central Utility Addition	-	-	3,000
<b>Total</b>			<b>17,791</b>

new buildings.

- ▷ Phasing of the new buildings and modifications to the existing ductbanks should be coordinated with the installation of the new dual feeder ductbank to maintain service to the existing buildings on the northeast side of campus that will be affected by ductbank demolition. Refer to Table 3 in the Appendix for a detailed

breakdown of each building.

- ▷ The double feeder on the west side of campus is adequately sized for the additional facilities and will not need to be upgraded at this time.



## PLUMBING- NATURAL GAS SYSTEM

### Existing Conditions

Southern California Gas (SCG) currently delivers natural gas service that is distributed throughout the campus from three major sources / streets surrounding the campus (Nutwood Avenue, State College Boulevard, Yorba Linda Boulevard.) From their existing 40# high pressure mains in Nutwood Avenue, State College Boulevard, and Yorba Linda Boulevard, SCG has multiple meter locations on campus providing service to the University. From each meter location, The University privately distributes medium pressure gas within the campus.

The 2014 P2S report has indicated portions of the campus distribution system being old and needing replacement. Concerns of inadequate isolation valves in the gas infrastructure and missing earthquake valves to the older facilities were also reported.

### Proposed Demand

Even with the push for reduction of the use of fossil fuel as indicated in the sustainability section, it is still expected that in the near term, the natural gas infrastructure would need expansion and repair. The replacement of old pipes, the installation of more strategic isolation valves, the installation of earthquake valves to the older building and campus-related expansion are the expected near-term upgrades for the natural gas infrastructure.

Refer to the projected natural gas future needs analysis Table 23.

### Recommendations

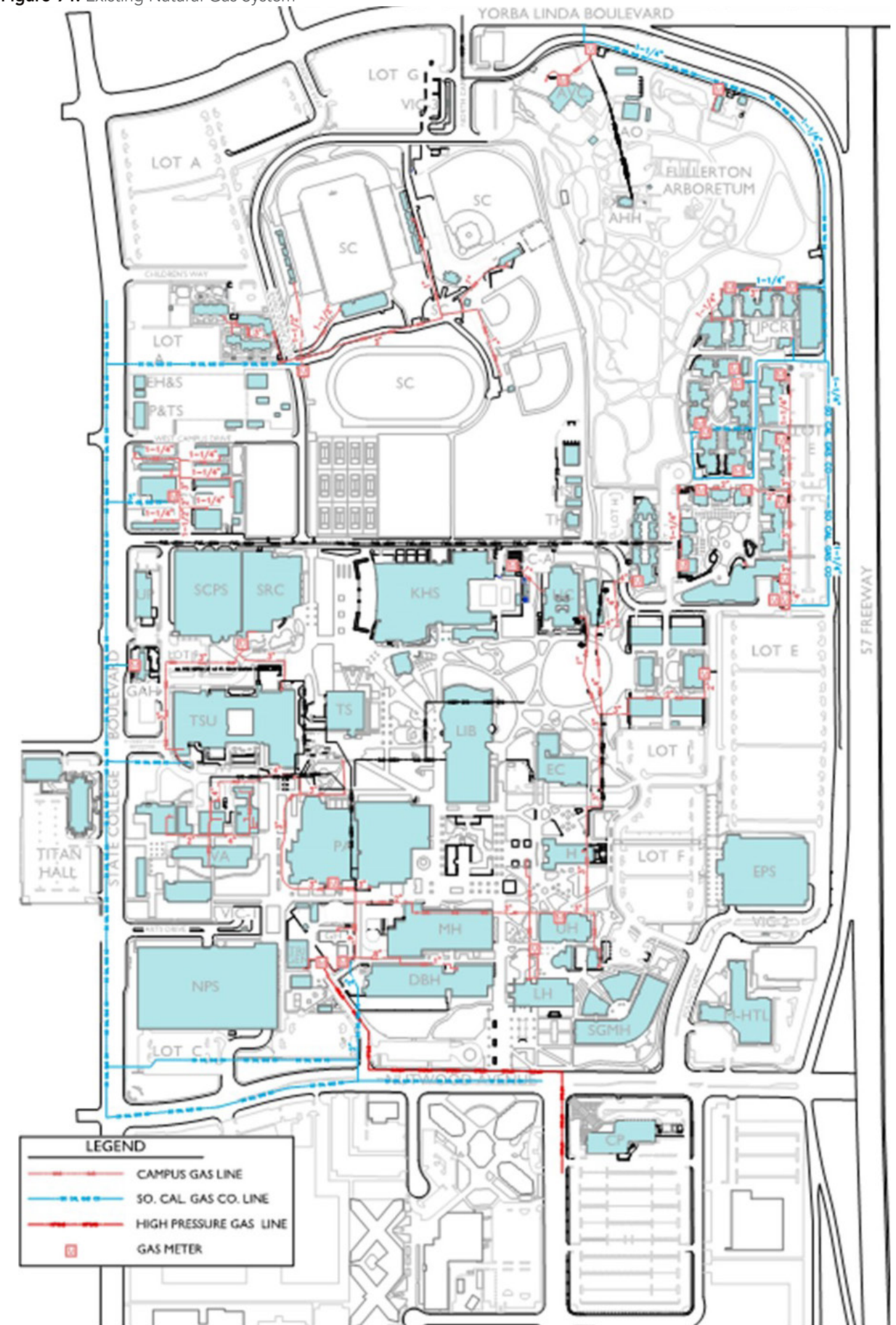
It is recommended that new service points and additional meter locations be requested by the University for as many of the expansion areas as possible. This would utilize gas rule

20 and 21 and refers to mainline and service pipe extension rules. Under rule 20 and 21, SCG will own and operate the gas system at their expense after the estimated value of the system installation is paid for in advance by the University.

**Table 23.** Future Natural Gas Loads

Building Name	Gross Area (GSF)	Gas Capacity Requirement (CFH)
New Student Housing	803,880	21,000
New Campus Amenities	800,000	20,000
New Faculty Housing	539,000	14,000
New Academic Space	881,526	23,000
New Non-Academic Space	40,000	1,000
New Innovation Center	72,762	2,000
New Facilities in Arboretum	100,000	3,000
New Event Center	254,100	10,000
Transportation Hubs	7,200	1,000

**Figure 94.** Existing Natural Gas System







# Resiliency

Adapting to global climate change and its impacts has become a central challenge of our time. This is part of a timeless challenge now experienced at an accelerated pace: to create environments that help communities survive and thrive in the context of change.

Places are affected by changes that occur slowly and those that occur suddenly, changes that are predictable and ones that are unforeseen. These processes are interconnected, each influencing the others.

Much as ecological systems are shaped by the interaction of hydrology and vegetation and climate, our regions, cities, and yes campuses, are shaped by economic globalization, changes in technology and communication, and climate change. How can we respond to these interacting processes, and in particular the threat posed by a changing climate, at the scale of the campus?

How can CSU Fullerton become a resilient place that can absorb and respond to change while maintaining its essential qualities?

Several aspects of this Master Plan will support a resilient campus in Fullerton in the years ahead. These include:

- The creation of a 24-hour community;
- The expansion of food options on campus;
- A shift to multi-modal mobility;
- The designation of critical buildings and infrastructure;
- A shift to adaptive landscape elements;
- The expansion of on-site electricity generation, and the creation of a microgrid.

---

## RESILIENCY GOAL

---

Strengthen CSU Fullerton's capacity to absorb and respond to change--and in particular, the threats posed by a changing climate--while maintaining its essential qualities.

---

### *FUTURE RESILIENCY PLANNING EFFORTS*

This chapter is an introduction to some of the aspects that should be considered when crafting a campus resiliency strategy; however, a comprehensive campus resiliency planning effort is recommended to monitor and track resiliency goals related to the reduction of GHG emissions, resource conservation efforts and emergency preparedness planning. This should be consistent with similar work that has been done at the city level (City of Fullerton's Climate Action Plan) and by other campuses like the Resilient CSU San Bernardino Sustainability Plan.



# STRATEGIES FOR A RESILIENT CAMPUS

## SOCIAL INFRASTRUCTURE

Today, a great majority of students commute to campus and tend to arrive for their first class and leave directly after their last. Campus ties for students, faculty and staff are limited by the relative lack of “third spaces” on campus where people can mingle.

Indeed, one of the drivers of this Master Plan is to build a 24-hour community on campus. The Master

Plan’s strategy for creating a 24-hour campus includes (1) a major expansion of on-campus housing and (2) a focus on new spaces and facilities designed for interaction, including the Innovation Center and the courtyards and plazas being knit into new campus development.

What does this have to do with resiliency? Two words: social

infrastructure. This term recognizes that, much as pipes and roadways are infrastructure for water and vehicles, buildings and spaces that nurture connections among people are infrastructure for community. Numerous studies have now indicated that communities with stronger social ties have proven to be more resilient in the face of crises.

## TRANSPORTATION

Travel patterns at CSU Fullerton today place a heavy burden on the regional transportation network, the arterials around campus, and the University’s parking facilities. The University’s functioning depends on tens of thousands of people getting across an increasingly gridlocked region and through the same intersections each day in private vehicles, most of which are dependent on the availability of affordable fossil fuels.

This Master Plan seeks to focus the University’s investments over the years ahead on buildings and spaces for learning and living - not for parking. The Plan emphasizes Transportation Demand Management (TDM) strategies to shift more travel to other modes and creating more destinations that can be reached easily with the “micro-mobility” options.

This shift will be needed to ease the parking and traffic crunch and to support sustainability goals. It will also make CSU Fullerton more resilient. With more good mobility choices, the campus is less vulnerable to the breakdown of one mode or another. People will be able to come and go quickly at critical times.

## SAFE BUILDINGS

CSU Fullerton is a “landlocked” campus on a relatively small site. To accommodate a growing university, this requires an evolution toward larger, more closely spaced buildings.

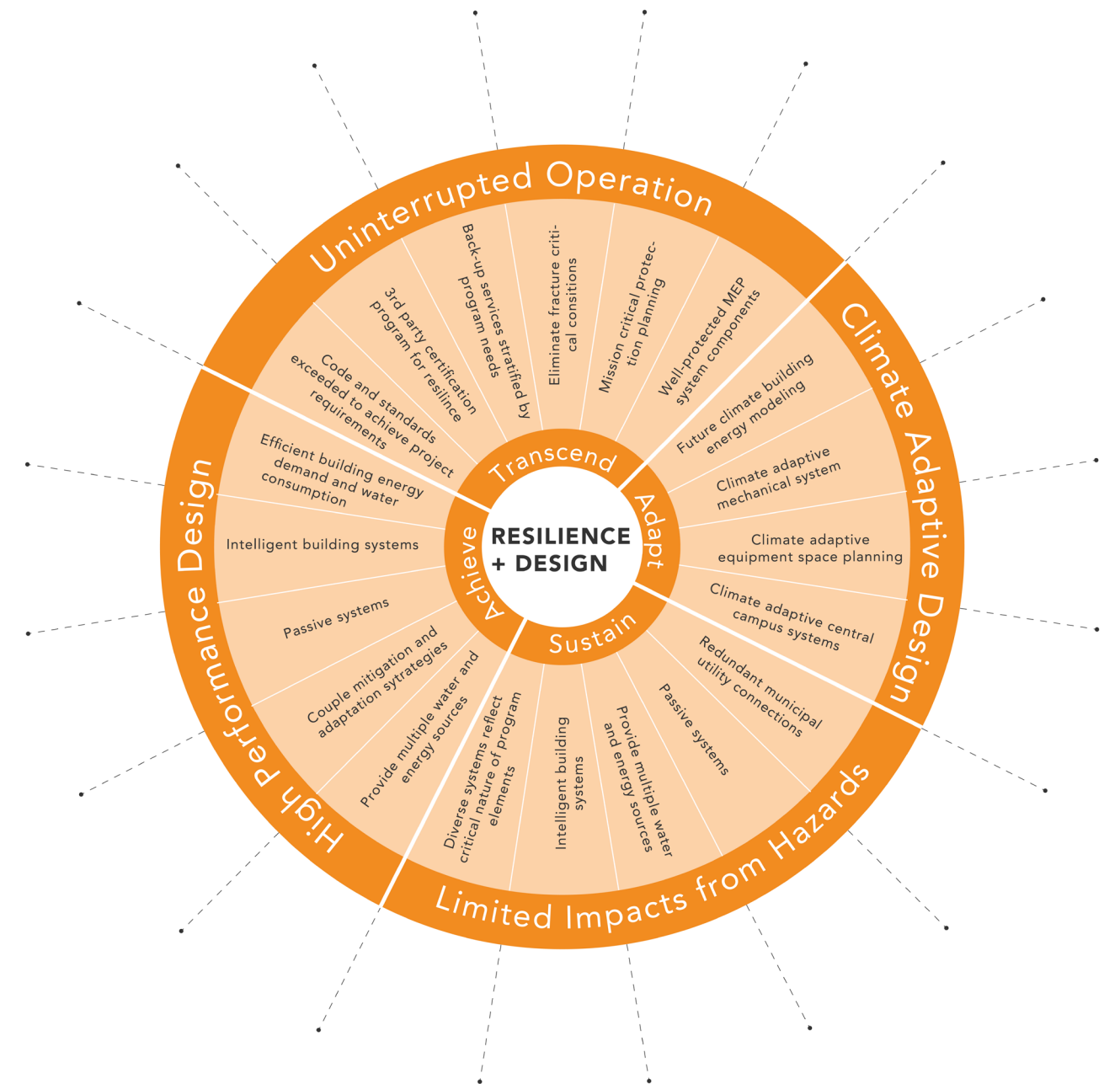
The new buildings identified in the Master Plan have been designed — at a conceptual level — to achieve the University’s space needs while adhering to the maximum height

allowed by fire codes for Type II construction. Over the next decades, the University’s “skyline” will increasingly reflect this fire safety consideration.

Meanwhile, the University will also update its emergency preparedness and evacuation procedures. As part of this, specific buildings will be identified as “critical infrastructure,”

designed to a higher seismic standard and with the capacity to shelter the University’s population during emergencies.

Each of the districts identified in the Master Plan should have a clearly identified Resiliency Hub that provides shelter and emergency preparedness resources.



## FOOD RESOURCES

Today, CSU Fullerton’s campus has limited food options. When the food courts and dining halls are closed, there are limited options within a reasonable walk of campus. The lack of food has an effect on the campus’s social life — see “Social Infrastructure” — and directly impacts how students choose to get around, either by car, bike, or other transit options.

The Master Plan recommends the creation of a new food commons serving the new residential neighborhood, and dispersed options for eating, shopping, and accessing basic needs distributed around campus.

The Plan also recommends the use of food-producing trees and plantings on campus to emphasize the

importance of local food production. Generally, providing the campus community with a diverse range of sustainable food options on campus ensures that the population will be supported in case off-campus options are offline or out of reach.



## WILDFIRE PREPARATION

As noted in the City of Fullerton Climate Action Plan, the City is not located within areas designated by the California Department of Forestry and Fire Protection (CalFire) as Very High Fire Hazard Severity Zones (VHFHSZ). But due to long periods of hot-dry weather and high velocity desert winds, the broader region's chances of wildfire make wildfire preparedness a high priority.

Smoke inhalation and air quality concerns for sensitive populations must be considered during nearby wildfire events. Emergency supplies should be made available for the campus population, ideally in clearly defined locations, like the Resilience Hubs identified for each campus district.

## PASSIVE SURVIVABILITY

CSUF should be prepared if an extended blackout were to hit the CSUF campus during a summer or autumn heat wave. This scenario could potentially impact even more people as the residential population of the campus grows. Avoid reliance on active systems that could be damaged by an earthquake or high winds, such as PV arrays. New buildings

should limit the amount of glass on east, south, and west-facing facades to 40 percent, and include exterior shading to limit heat gains from the sun. Windows should be operable, especially in residential buildings and gathering places. New buildings should be designed with daylight access in mind.



## UTILITY RESILIENCE

Incorporating resiliency as a core element in MEP system design is critical for overall campus resilience. Some of the general MEP resilience measures are listed below:

- Seismic restraints and retrofit for applicable MEP equipment, including Central Utility Plant and Thermal Energy Storage Tanks.
- Location of critical building MEP systems above flood plain.

### MECHANICAL SYSTEM

Some of the mechanical system specific resilience measures for consideration are listed below:

- Utilization of predicted future weather data that incorporates the changing climate metrics based on Green House Gas (GHG) emission scenarios.
- Space and capacity for “future” carbon filters for Air Handling Units.
- Fan redundancy.

### ELECTRICAL SYSTEM

Some of the electrical system resilience measures for consideration are listed below:

- On-site power generation (Photovoltaics).
- Energy Storage.
- Microgrid with islanding capability.

### PLUMBING SYSTEM

Plumbing campus resiliency involves the redundancy of system components or functions of critical plumbing systems with the intention of increasing reliability for a fail-safe system performance. Some of the plumbing system resilience measures are listed below:

- Equipment redundancies – All renovation and new building plumbing equipment shall be sized at minimum 60 percent load with N +1 minimum redundancy. Plumbing system configured with one unit in operation and one on stand-by shall ensure continuous operation of the plumbing system serving the building.
- Water supply redundancy- Critical buildings such as central plants shall be supplied with water connected from at least two different water mains located on different streets. The redundancy in supply protects the building from a water outage in case the water supply from one main is interrupted.

- On-site drinking water reserve - All critical buildings shall have an adequate supply of on-site water to operate essential utilities and equipment for a minimum of 24 hours. This will provide continuous operation of water supply and safeguard against the event of a water outage. The on-site water reserve shall have the capability to be replenished by transportable water sources and is capable of dispensing water to portable containers in the event that normal water supply becomes unavailable.
- Provision of dual fuel boilers for central plant heating system- natural gas shall be used as the primary energy source and fuel oil shall be used as an alternative in case the utility company supply is interrupted. In addition, fuel oil tank supply of not less than for 24 hours usage shall be provided.



# SUSTAINABLE STRATEGIES

## WASTE MANAGEMENT

Throughout the master plan process, the CSUF community has consistently expressed a strong commitment to reducing material waste. Given the level of interest by the campus community, CSUF should demonstrate its leadership on this issue.

CSUF should make recycling easier by opening an on-campus recycling center, increasing the abundance of waste repository sites, and dedicating space for electronic waste recycling. Recycling and compost bins should be provided wherever there are garbage bins. (Composting bins are

not currently present on campus.) Clearer signage should be developed and widely implemented to indicate proper recycling and composting procedures. CSUF student research has indicated that better signage could yield a 25-30 percent improvement in diversion rates. CSUF should share information about what happens to recycling and waste collected on campus.

The Arboretum currently has industrial scale composting, but only for arboretum waste. This composting facility should be expanded to compost waste from the campus.

CSUF should take action to eliminate single-use plastic: through policy, purchasing decisions, tenant lease agreements, and education strategies. CSUF could follow the lead of San Francisco International Airport by prohibiting sales of single-use plastic water bottles. Bottle filling stations should be provided throughout the campus to offset the need for the community to purchase beverage bottles.



## WELLNESS

CSUF should dedicate a “restorative outdoor space” open to all campus community members of at least 800 square feet, following the guidelines of the WELL Building Standard v2 M07 Restorative Spaces feature as a guideline.

The campus values its open space for recreation. Future building sites and parking sites should not sacrifice open space. Bicycle infrastructure and parking should be expanded to encourage human-powered transportation.

The university should consider on-campus food production near the dormitories or in parking lots to generate healthy food and support students who are food insecure. Large planters work well. Food production provides training opportunities.

## SOCIAL EQUITY & DIVERSITY

By developing land CSUF already owns to accommodate additional housing, made available to the community at affordable prices, CSUF can improve social equity. New student housing should incorporate a variety of occupancy and space configurations to serve different budgets. Adding housing options for faculty and staff members can help attract and retain talent from all economic backgrounds.

Some members of the community lack access to healthy and affordable food. By adding new physical space for food service and seeking a tenant that provides healthy options, CSUF can reduce the barriers to obtaining healthy food for those who don't have the time or means to leave campus to get a meal.

In all building types, CSUF should implement universal design principles



to make buildings accessible for all users. CSUF should consider upgrading existing buildings that will not otherwise be renovated, for accessibility.



## EDUCATION

The Sustainability Policy requires that buildings are designed and built to LEED Silver standards but does not require certification. CSUF should establish a policy of pursuing LEED certification in lieu of equivalence. LEED certification is an educational opportunity for the campus; seeing a LEED certification plaque inspires curiosity and in turn learning about what it means.

CSUF has made strides in reducing the electric consumption of the

campus. It should make energy performance more visible using signage and interactive displays.

CSUF faculty and staff should look for opportunities to integrate a “working/learning” campus, using the physical campus as a means for hands-on education. Opportunities range from systems within new buildings to landscape species on the campus and in the arboretum.



## CARBON SEQUESTRATION

Among aspects of campus design, landscape is uniquely able to absorb and sequester carbon over time, rather than acting as a carbon source, if implemented thoughtfully. However, the carbon sequestration potential of landscape is relatively minor compared to the embodied carbon of construction materials and the operational carbon emissions of operating a campus like Cal State Fullerton; so the University must look beyond landscape to offset its carbon emissions. As a rule of thumb, each thousand square feet of typical new commercial buildings requires about 7,500 trees to offset carbon all emissions.

The best near-term strategy for CSUF to use landscape to sequester carbon over the coming decades is to plant as many trees as possible that will grow large, quickly. Tree size is directly

correlated with carbon sequestration potential. Woody shrubs are the next most effective planting option, followed by natural, unmanicured lawn (such as no-mow fescue). At the other end of the scale, manicured lawns can be a carbon source, rather than a carbon sink, so mowed grass areas should be minimized and removed except where needed for recreation.

Fertilizing impacts carbon footprint too. CSUF should use mulching to avoid the need for chemical fertilizer, composting landscape waste from throughout the campus at the Arboretum, and/or generating mulch alongside compost.

Plant material decomposition releases the carbon that has been sequestered. For long-term carbon storage, soil management has the greatest impact. Roughly 18-20 percent of carbon

sequestered in a landscape goes into the soil. Biochar is a soil amendment that can both improve soil fertility and sequester carbon in the soil for up to thousands of years. CSUF should consider developing a biochar production facility at the Arboretum. CSUF should also minimize the practice of importing and exporting soil to and from the campus, to reduce carbon emissions associated with moving soil.

To reduce the embodied carbon of site hardscape, CSUF should minimize paved areas and incorporate recycled content from demolition of existing concrete and asphalt into new paved areas with little vehicular load. Consider biosphalt and cement substitutions for concrete paving. Use wood decking where possible.



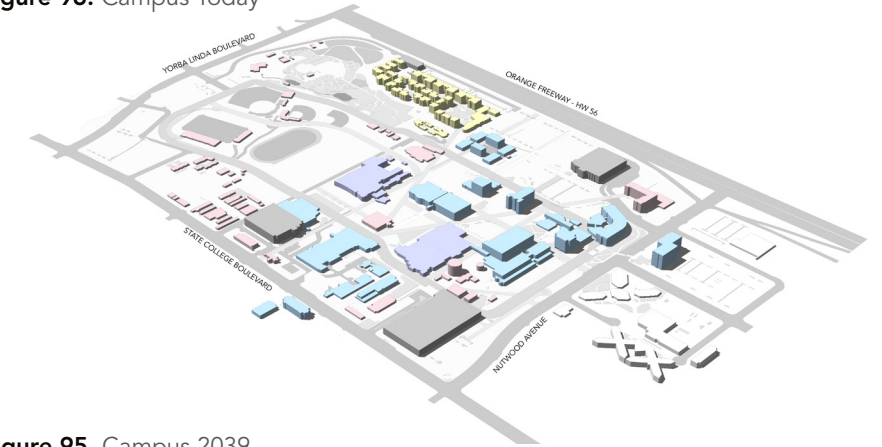




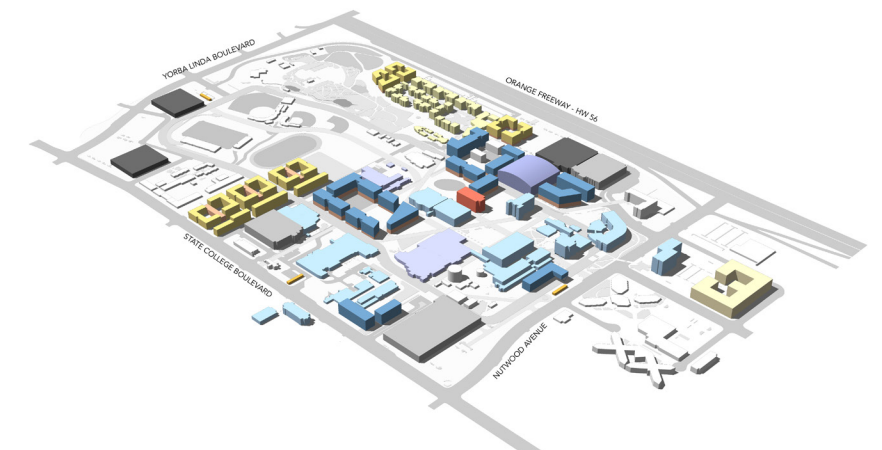
# Implementation

The following implementation plan communicates a conceptual approach to how the various program and design elements highlighted in the previous sections can be executed. While some projects have dependencies on others (e.g. the gym in KHS should not be removed until the Event Center is built) there is some flexibility in how the plan can be built out. Funding will be the single biggest driver of when projects can be realized, so the University is encouraged to explore multiple funding strategies to help realize the plan. This master plan adds twice as much spatial capacity within the campus boundary, suggesting the need for a carefully laid out strategy if the university wishes to strive for the complete vision of this master plan and associated growth. It is important for the campus to add academic buildings to match the need for the projected FTE growth.

**Figure 96.** Campus Today



**Figure 95.** Campus 2039

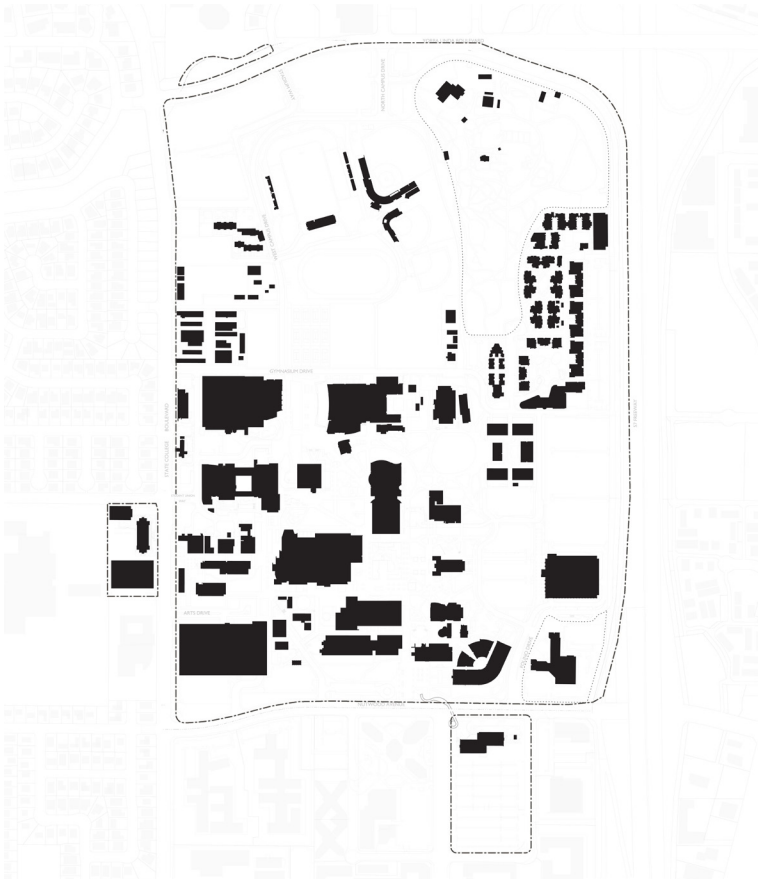


**Table 24.** Projected FTE Growth and Required Academic GSF

Year	FTE Projected Growth	Faculty Staff	Cumulative New Academic GSF Required	Academic Replacement	Total Cumulative Academic GSF Required
2020	26,470	4,447	298,331	-	298,331
2024	27,545	4,627	401,714	32,663	434,377
2029	28,950	4,864	538,018	-	538,018
2034	30,426	5,112	682,618	33,484	716,102
2039	31,978	5,372	831,002	131,732	<b>1,028,881</b>

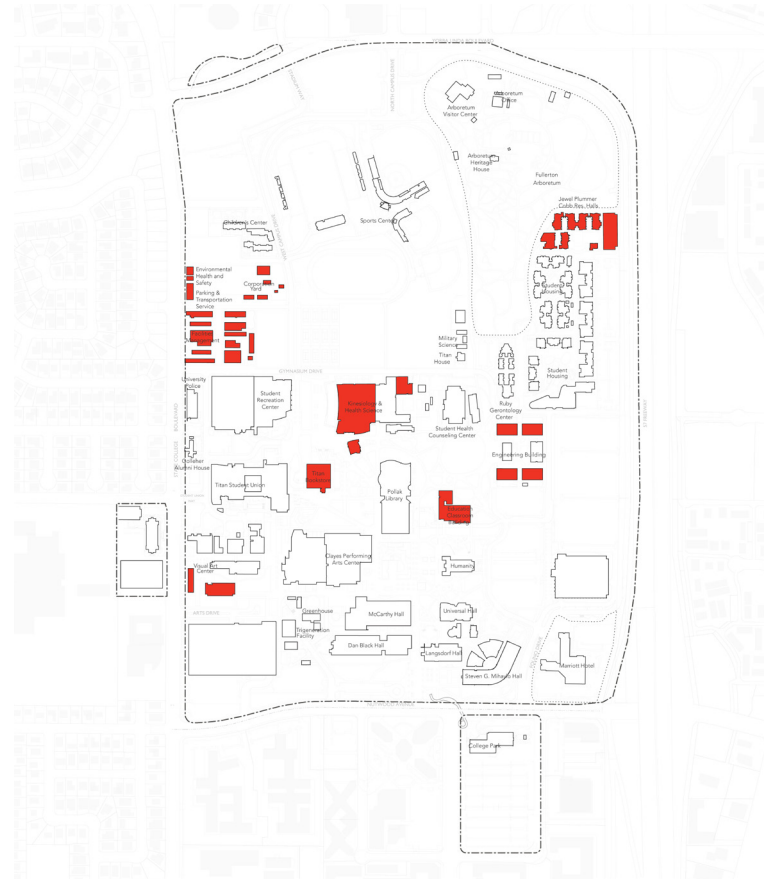


# IMPLEMENTATION ASSUMPTIONS



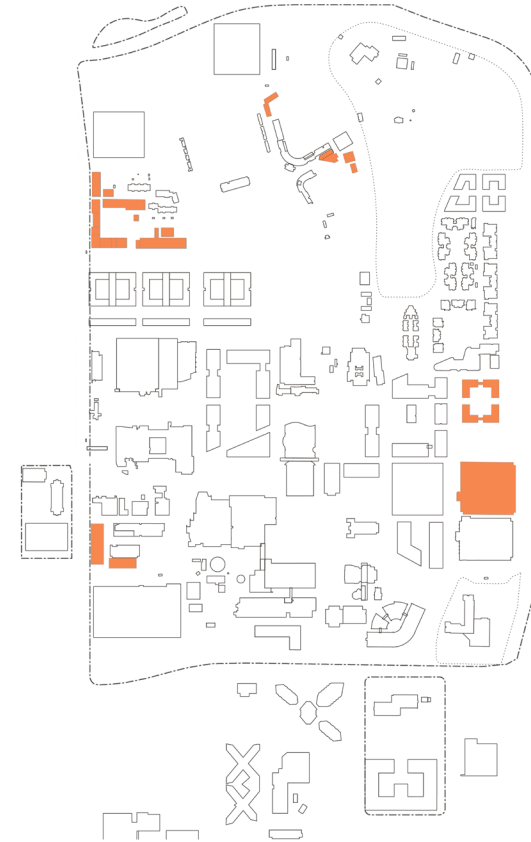
## Existing conditions

The current conditions representing facilities that are existing on campus today.



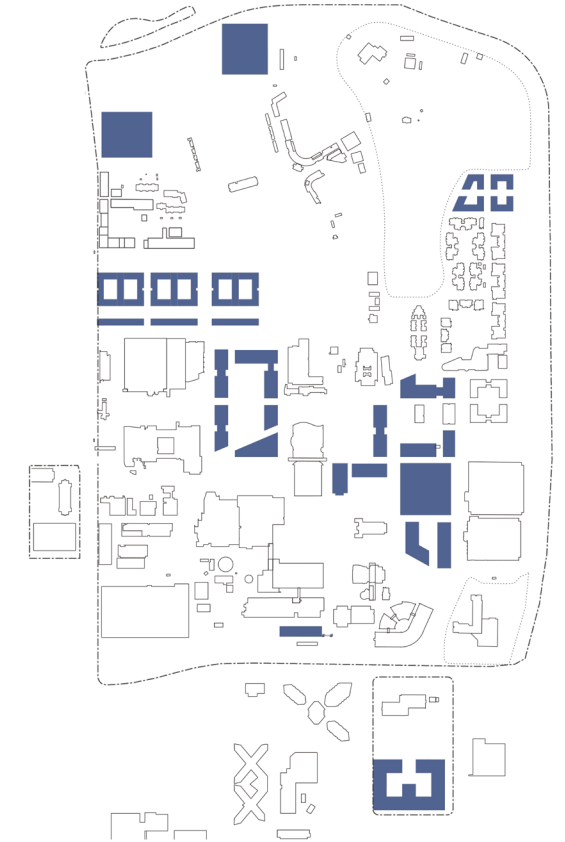
## Potential buildings to be replaced

These buildings have been proposed to be replaced or removed for further development.



## Projects approved, pending construction and addressed in previous EIR evaluations

This plan represents short-term development, including facilities that are existing on campus and those that have been reviewed by the Board of Trustees and approved for construction. This includes the East Side parking structure, Corporation Yard, 600 student beds, upgraded baseball facilities, and additional space for visual arts. Proposed facilities in the 2003 master plan but not yet implemented are not included, for example the science laboratory replacement building.



## Proposed PMP 2039 build out and basis for current EIR

The proposed 2039 Campus Master Plan (Development Plan) defines the vision for the future and identifies current buildings and Board of Trustees approved facilities as 'existing'. Facilities that are being considered for replacement and all potential new facilities, together with open space development, are also identified.



## IMPLEMENTATION PRINCIPLES

While there is flexibility in the sequencing of projects, there are some guiding principles that should be considered throughout the plan period to reach the full vision of this master plan. An essential part of the strategy is to implement these key framework principles from the outset.

**Achieve maximum density on each site:** In order to achieve the highest and best use of the campus land, the building density goals should be met. Developing low-rise buildings will reduce the ultimate capacity of the campus.

**Build the framework as you go:** Honor the framework plan so that the overall intent of the master plan can be realized. The integrated nature of the plan relies on the buildings and open space working in tandem with each other, each playing a vital role in achieving the overall goals of the plan.

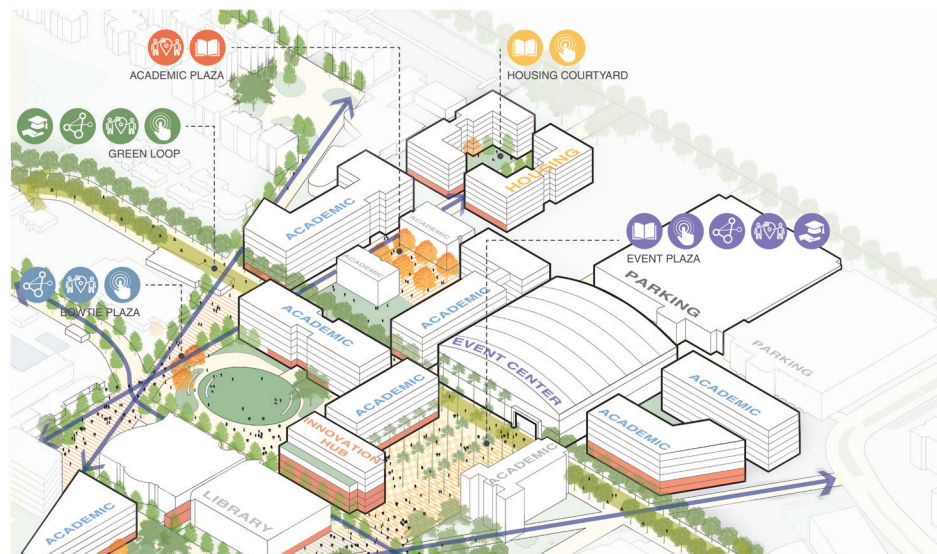
**Achieve the mix of uses in each phase:** Implementation should target an ongoing blend of programs (academic and nonacademic) over time so campus life can be elevated

consistently and effectively, making sure the physical space supports the evolving academic needs including student life, amenities and interdisciplinary learning spaces.

**Implement TDM strategies:** Developing the TDM programs to maintain a medium level of mitigation is critical so the growing campus community can accommodate the additional traffic to and from campus.

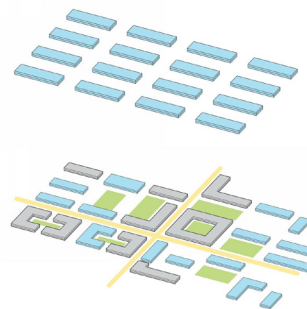
**Updated infrastructure:** Infrastructure is the backbone to maintaining operations and a functional campus. Capacity upgrades and sustainable practices should be integrated throughout the plan duration and not considered as a discretionary add on.

*Cohesive districts can be achieved by careful composition of uses and densities. A thoughtful implementation is essential to create great places on the campus.*

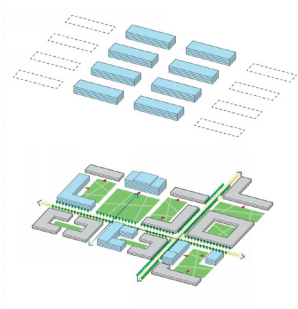


*Low-rise building occupies larger footprints and leave less flexible future growth. The conceptual diagram below suggests the flexibility gained with density and building higher, leaving more space for programmed open space and future growth.*

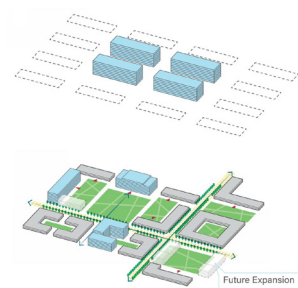
### 1 TO 2 FLOORS



### 4 TO 6 FLOORS



### 8 TO 12 FLOORS

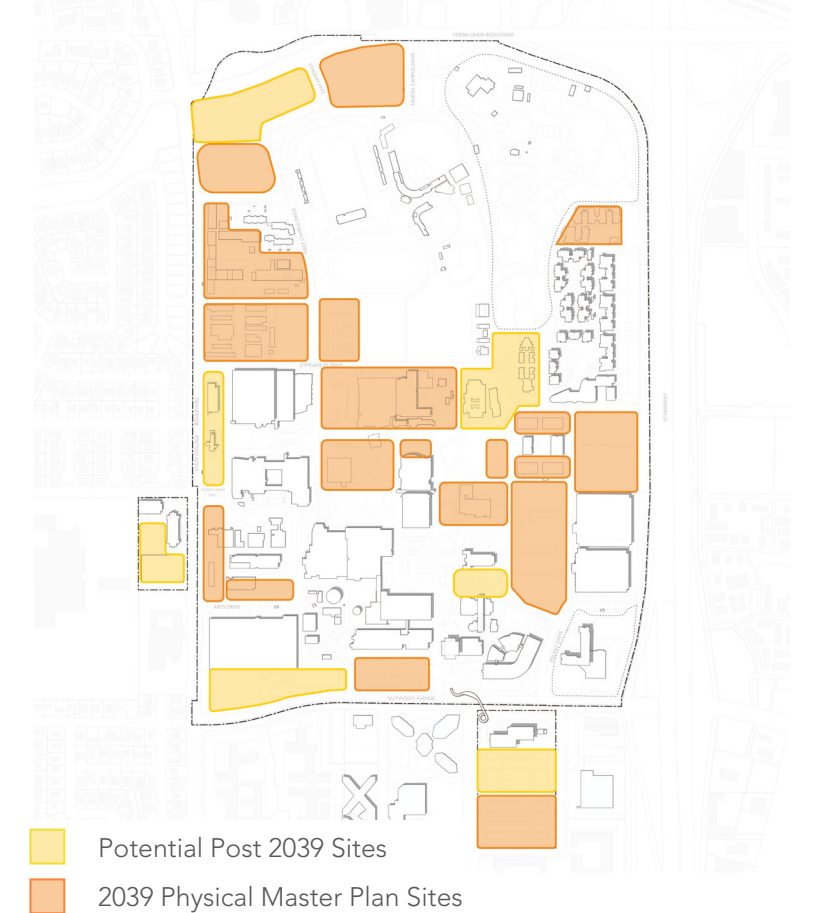


## IMPLEMENTATION CHALLENGES:

The proposed implementation strategy carefully focuses on overcoming the following challenges:

- A landlocked campus, making it increasingly difficult over time to find vacant parcels to add new buildings without disturbing the current functions.
- Lack of surge space to accommodate current functions, facilitating the demolition of old buildings or the start of renovation projects.
- The current parking supply is under pressure, making it very difficult to build over the surface parking lots.

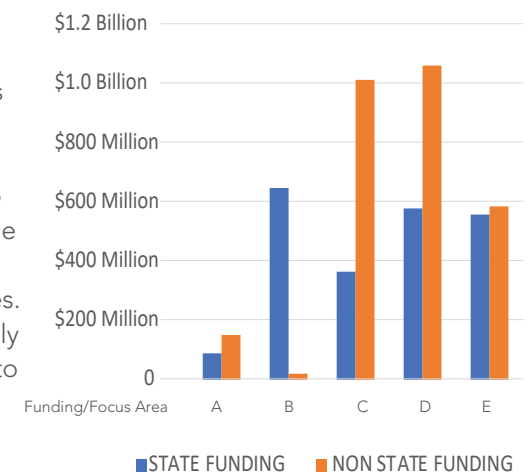
Figure 97. Opportunity Sites, Existing and Future



## FUNDING AND COST PROJECTIONS

Funding availability remains undefined, which limits the ability to specify dates or timelines for the construction and implementation of the physical improvements. With the anticipated limit to state funding, the University will need to review alternate funding strategies, public private partnerships, and collaborations with nonacademic enterprises to realize the campus vision. For the purposes of this master plan it is assumed that all academic space programs will be funded by the State. The remaining project scopes are funded from various sources (donor/partner funding – typically married with a state function, parking fees, student fees – requiring a vote, and housing rates (similar to market housing, etc.).

The projected costs associated with each phase have been developed based on the CSU cost guide in the CPDC 2-7 form (CCCI 6151/EPI 3202) for the various types of academic space and industry benchmarking for nonacademic space and includes a 33 percent add for project soft costs. Given that new academic buildings have not been assigned to a specific College or Department, the costs have been calculated using an aggregated value across all use types. The cost projections have additionally been inflated by 5 percent per year to address escalation.





## PROJECT ROLLOUT

With the 20-year time horizon of the master plan to 2039, the roll out has been divided into five categories, each focusing on a programmatic theme or timeframe. While the program blend is modified within each of these focus areas depending upon the intent, there remains a strategic sequencing for the rollout based on achieving the stated goals of the Physical Master Plan. The following program descriptions outline the considerations for each of the individual program typologies:

**Academic Space:** The demand for additional academic space is driven by FTES growth, defined at a constant 1 percent annual increase. The Immediate focus is assumed to accommodate the current shortfall of entitled academic space on campus. The progressive addition of academic space over time is calculated for all Colleges and the Physical Master Plan does not define which academic function should be located in any one particular location. This strategy is important since it provides flexibility to the University in determining how, when and where additional pedagogical spaces are added.

**Nonacademic Facilities:** The timing and addition of nonacademic space is not regulated by FTES entitlements, allowing for greater flexibility in timing. The University will have the ability to build these facilities as funding becomes available, supporting the campus life vision of the plan, rather than being driven by FTES. The implementation plan should, however, consider adding the

requisite amounts of nonacademic space consistently throughout the plan duration in line with academic space growth, to ensure that a balanced blend of program functions are provided for the campus community.

**Housing:** With the move towards a residential campus supporting academic persistence, the sequencing considers the addition of housing as a major driver to achieving many of the plan goals. Incremental growth and housing additions are anticipated so that housing absorption rates can be monitored and coordinated with the required additional campus life programs that are critical to developing a well-balanced campus community.

**Open Space and Circulation:** It is important the proposed open space components and connectivity needs are implemented as part of the site work for each building project and beyond. Leveraging external spaces for informal learning will play a crucial role towards achieving student success and identity creation.

**Transportation Demand Management Programs:** Several elements of a strong TDM program are currently in place, but the strategies suggested in this Physical Master Plan focus on formalizing a TDM program, bringing all the pieces under one vision, and building upon existing strengths. Fundamental to success is ensuring there is staffing to initiate, implement, and manage these efforts. Also, key is using

communications tools to get people interested in all the other programs and initiatives. Measuring results carefully and consistently will help to track progress and refine approaches as travel behavior changes.

TDM and mobility infrastructure improvements are interrelated, and both should be considered in coordination with decisions about parking investments. Over the long-term, TDM and mobility improvements can reduce parking demand and parking pricing and management can create more open parking spaces as well as fund TDM programs. Lastly, creating parking spaces is surprisingly expensive – where and when those dollars can be better spent on TDM measures, they should – in support of campus goals and CSU climate mandates.

A full TDM program that combines physical improvements, incentives, outcome tracking, and scales consistently over time is most effective. Implementation does not occur overnight, but rather takes thoughtful phasing, managed by a consistent owner/tracker, and can find cost efficiency with ongoing capital and infrastructure investment suggested in this Physical Master Plan.

Good TDM programs do not succeed without long-term organization commitment, as the most effective measures require ongoing operations and management, and the multi-modal vision must be consistently integrated into future infrastructure projects around campus.

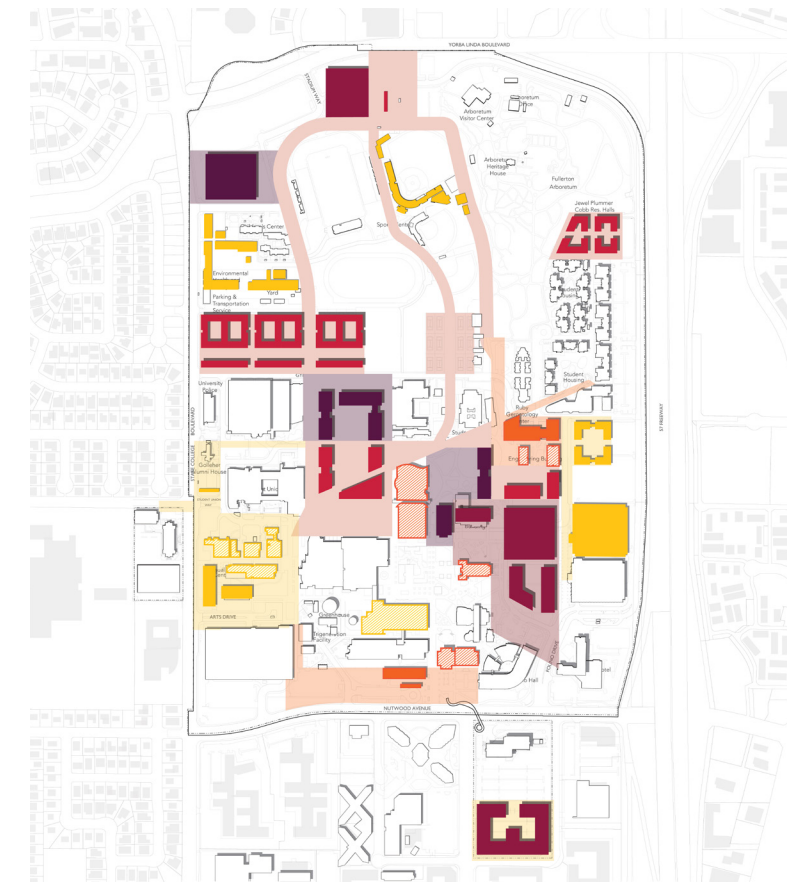
## IMPLEMENTATION OF FOCUS AREAS

Implementing the Physical Master Plan should be governed by making incremental improvements to the campus, aligning with the goals of the current Campus Strategic Plan, The Academic Plan and Physical Master Plan.

The five key focus areas are:

- Focus A : Immediate Projects
- Focus B : 5-Year Capital Plan
- Focus C : Residency
- Focus D : Community
- Focus E : Pedagogy

Figure 98. Proposed Implementation Focus Areas



Combination of state and non state funding is required to achieve the full visions of this master plan.

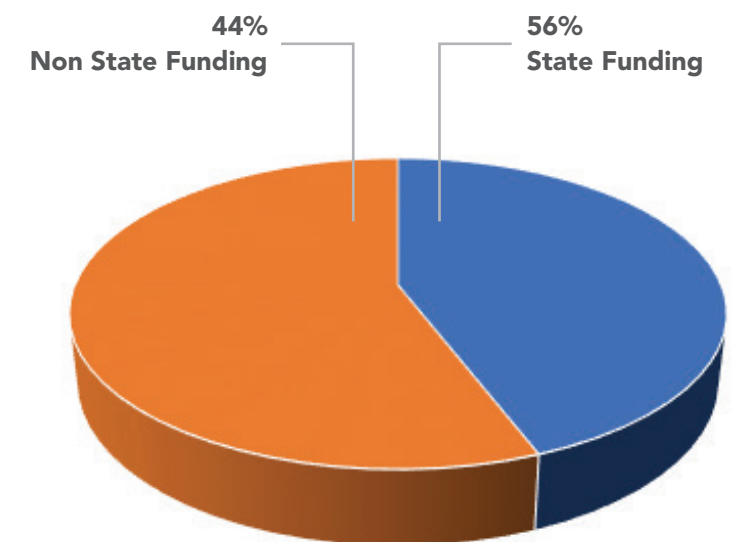
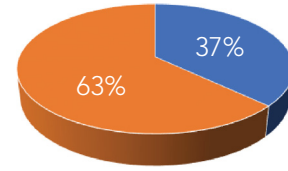
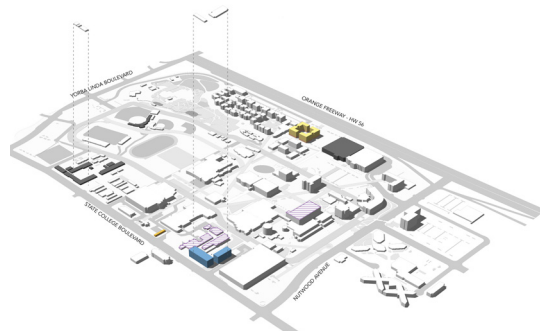


Figure 99. Cumulative Funding Proportions for Master Plan 2039

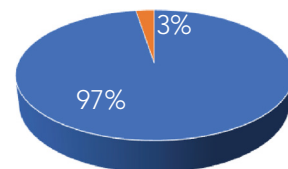
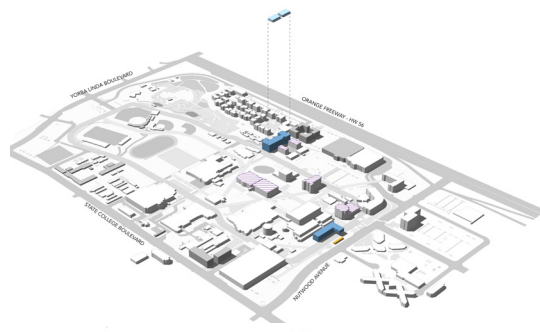


Phase 1: Immediate  
Phase 2: 5 yr CP  
Phase 3: Housing  
Phase 4: Event Center  
Phase 5: Student Life

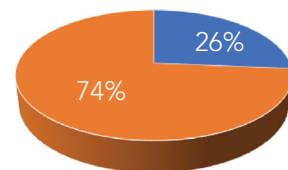
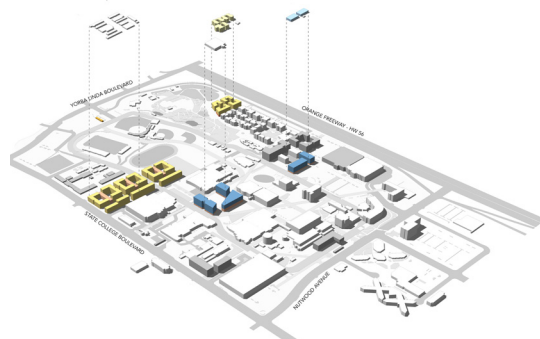
The projects that have attained funding and approvals and can be implemented immediately to further the academic mission of the university.



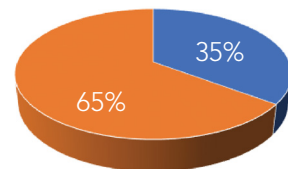
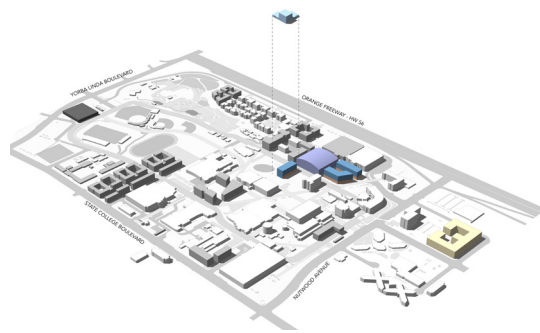
The primary objective of the Five-Year Plan is to provide facilities appropriate to the CSU's approved educational programs to create environments conducive to learning.



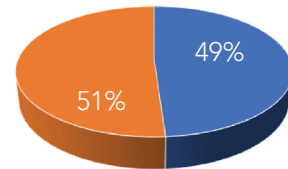
A key initiative for success is student persistence and support of the Graduation Initiative 2025. A fundamental component to this is to move the campus from a commuter to a residential campus.



Providing facilities that create opportunities for town and gown interactions on-campus activities such as commencement, cultural events, exhibits and trade shows will all contribute to creating a sense of place.

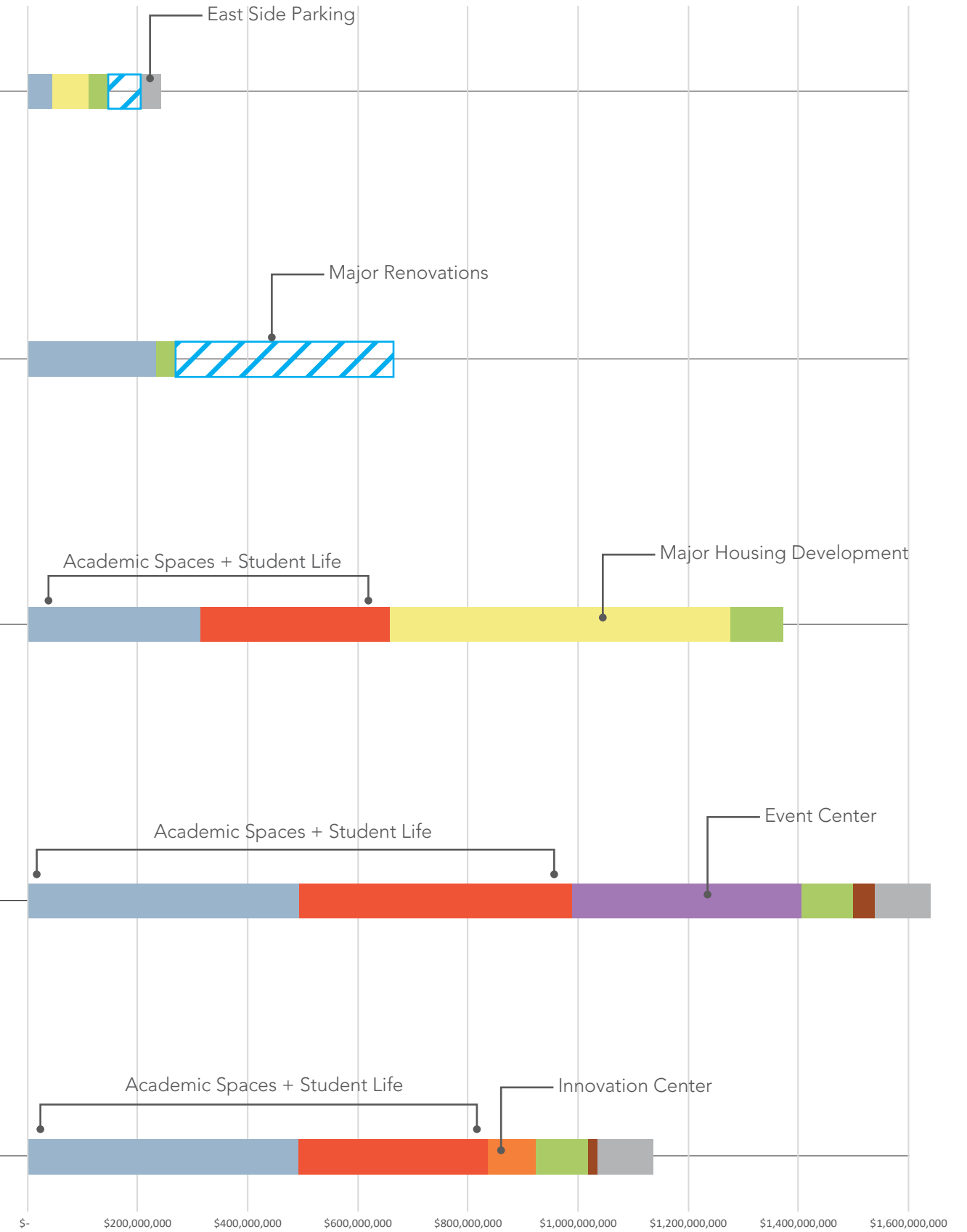


Central to the University's mission is how to academically engage students, creating opportunities and preparing them for the future.



Funding Sources per Focus Area

STATE FUNDING NONSTATE FUNDING



Cost by Land Use per Focus Area

Academic Student Life Housing Innovation Center Event Center Open Space / Site Work Renovation Demo Parking Garage

Figure 100. Implementation Focus Area Summary



## FOCUS AREA A: IMMEDIATE PROJECTS

Goal: Continue to improve the campus environment with projects that have attained funding and approvals and can be implemented immediately to further the academic mission of the university. All aspects of the buildings will be improved as needed to support program needs and student success for another 50 years.

### Projects:

- **McCarthy Hall Renovation:** The project will renovate, enhance, and upgrade the second floor of McCarthy Hall, comprising faculty and student collaboration areas, informal learning space, and activate circulation areas along with required code upgrades. The project ASF is 26,271 and GSF of 40,968.
- **New Student Housing:** This project will construct a new 118,000 ASF/182,000GSF, 600-bed, semi-suite style student housing facility to address the demand for student housing and provide more opportunities for students to live on campus and engage in activities that support their success. This new building will be primarily for sophomore and junior students with three staff and graduate student apartments, lounges, recreation space, a 300-seat multi-purpose room and housing support functions. Proceeding with this project will be dependent on the development of an affordable student housing plan.
- **East Parking Structure:** The proposed parking structure will add 1,900 parking spaces on a five-level deck. Located approximate to the future Event Center, it will serve many functions close to the campus core.
- **Visual Arts:** The proposed project will renovate 107,600 GSF of

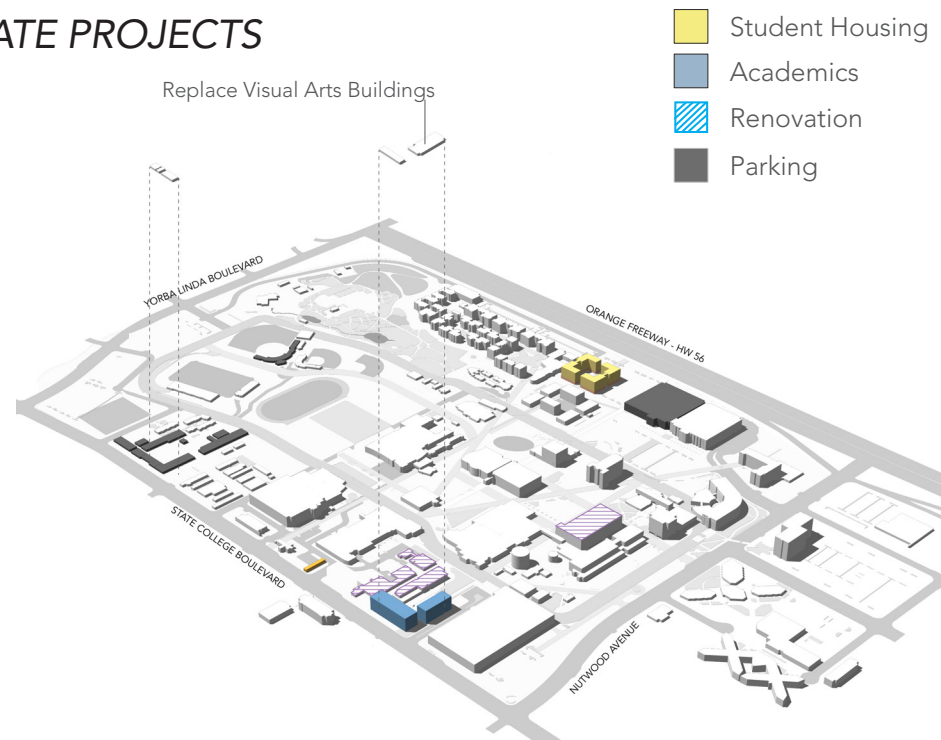


Figure 102. Massing Model: Focus Area A

- six existing buildings in the Visual Arts Complex which were constructed in 1969. The Visual Arts Complex is a home to the College of the Arts with a large number of teaching laboratory spaces. It accommodates 490 FTE (216 lecture, 111 lower division laboratories, 163 upper division laboratories), and 36 faculty offices. The project will correct functional, building code and programmatic deficiencies and extend the service life of the complex.
- **Corporation Yard:** The existing outdated physical services complex will be moved north on campus, freeing up valuable land closer to the academic core. The replacement buildings will allow the campus to be better served and elevate the use of campus land.
- **Baseball Field House:** This project will demolish existing locker rooms and coaches offices and build a new team building in the same location to house both the baseball

- and softball teams. A new entry pavilion and press box will also be constructed. The new construction will address accessibility issues and maintain access for emergency vehicles. The project will be self-supporting from fees paid by patrons.
- **Open Space:** Incremental improvements to the campus circulation pathways, open spaces and landscape should be coordinated with adjoining building projects as outlined in the Physical Master Plan. The concept of reinstating the Green Loop will take many years; however with incremental implementation this will allow for phased planting and deployment of learning opportunities, environmental graphics, and exercise areas associated with this feature.
- **TDM:** With the addition and improvement of space, the development and management of new TDM measures should be implemented to reduce the impacts of transit on campus.

Figure 103. Plan: Focus Area A

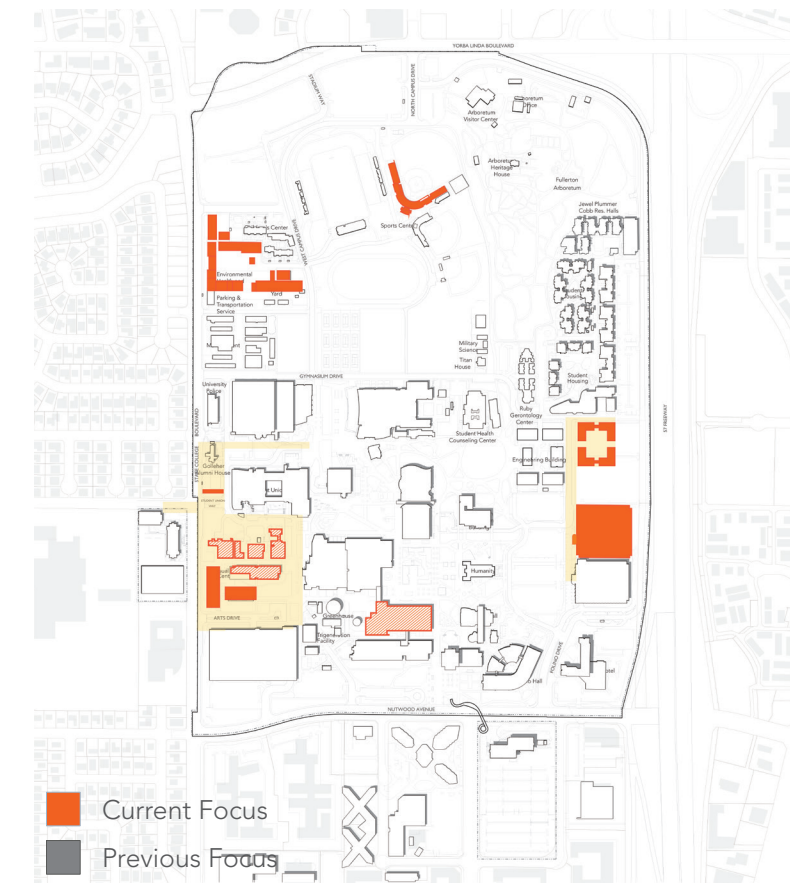


Figure 104. Funding Proportion: Focus Area A

■ STATE FUNDING ■ NON STATE FUNDING

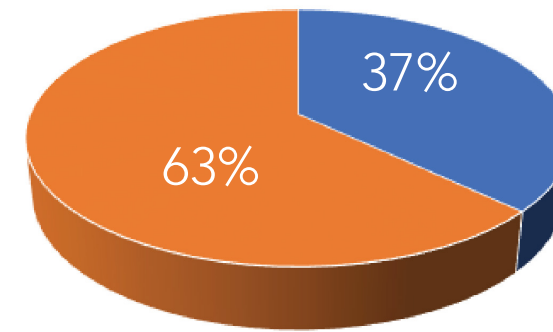


Table 25. Area and Cost Estimation: Focus A

Funding	Space Type / Project	Rounded Cost per Unit	Area / Beds / Units	Cost	No Escalation Included
State	McCarthy Hall Renovation	\$703	40,000 GSF	\$28,804,000	\$28,804,000
Non State	New Student Housing	\$87,928	600 beds	\$52,756,800	\$52,756,800
Non State	East Parking Structure	\$84	450,000 GSF	\$38,000,000	\$38,000,000
State	Visual Arts	\$407	107,631 GSF	\$43,754,000	\$43,754,000
Non State	Corporation Yard	\$327	55,000 GSF	\$18,000,000	\$18,000,000
Non State	Baseball Field House	\$591	20,300 GSF	\$12,000,000	\$12,000,000
State	Open Space	\$85	200,000 GSF	\$17,000,000	\$17,000,000
Non State	Open Space	\$85	200,000 GSF	\$17,000,000	\$17,000,000
				<b>STATE FUNDING</b>	<b>\$89,558,000</b>
				<b>NON STATE FUNDING</b>	<b>\$152,317,677</b>
				<b>TOTAL PER FOCUS AREA</b>	<b>\$241,875,677</b>



## FOCUS AREA B: FIVE-YEAR CAPITAL PLAN

Goal: The current California State University Five-Year Capital Plan outlines anticipated projects that will further the University's goals. The primary objective of the Five-Year Plan is to provide facilities appropriate to the Cal State Fullerton's approved educational programs to create environments conducive to learning and to ensure that the quality and quantity of facilities at the campus serve the students equally well. The following are the current approved projects.

### Projects:

- **Surge Building:** The program will construct a 60,000 ASF/92,000 GSF Science Laboratory Replacement building to replace fume hood intensive wet labs in McCarthy Hall as the first phase of multiphase/multiyear renovation of 182,900 ASF/ 310,000 GSF McCarthy Hall, the first permanent building on campus that was constructed in 1963. Due to the size of McCarthy Hall and the complexity and costly surge space requirements for wet labs for McCarthy Hall renovation, construction of a permanent building is more cost effective than rental of temporary modular facilities.
- **McCarthy Hall Future Phases:** This project includes additional renovation phases of the 182,900 ASF/310,000 GSF McCarthy Hall, a six-story, science building constructed in 1963. The project will focus on implementation of selected improvements to the building's core utilities infrastructure; remodeling of the basement and first floor (80,000 GSF) to principally accommodate lecture and dry laboratory spaces; and remodeling of the west wing of floors two, three, four, and five (80,000 GSF) for interdisciplinary lecture space and laboratory space.
- **Engineering and Computer Science Complex Expansion**

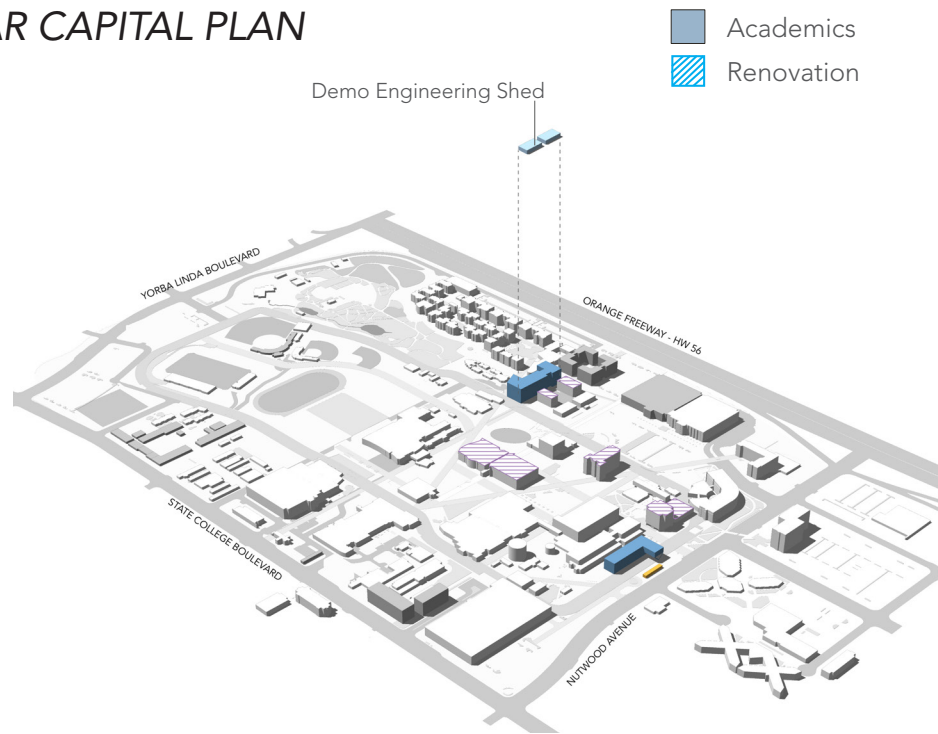


Figure 105. Massing Model: Focus Area B

• **Engineering and Computer Science Complex Renovation:** This project will renovate the 84,600 ASF/125,600 GSF Engineering and Computer Science Complex. The buildings house the College of Engineering and Computer Science that accommodate 1,207 FTE (972 lecture, 202 lower division laboratories, 33 upper division laboratories), and 73 faculty offices. The project will correct functional, building code and programmatic deficiencies and extend the service life of the complex. The proposed project will also construct a 36,700 ASF/51,000 GSF addition to support the growth of the college.

- **Humanities Social Science Renovation:** This project will renovate the 147,000 GSF Humanities Social Sciences building. The building was constructed in 1969 and is in need of comprehensive renovation. The goal of this proposal is to renew Humanities Social Sciences so that it supports current and future academic needs, functioning and performing to current standards,

as though it is a new building, and launching its service for another 50 years.

- **Langsdorf Hall:** This project will renovate the 91,000 ASF/141,600 GSF Langsdorf Hall building. The project will correct functional, building code and programmatic deficiencies and extend the service life of a 47-year-old campus building.
- **Pollak Library Renovation, Phase 2** This project represents the remaining phases of a four-phase project in an effort to improve Pollak Library in accordance with the system-wide "Library of the Future (LOFT)" initiative. The overall goal is to adapt Pollak Library (411,000 GSF; built in 1964 and 1995) to 21st century library practices and methods, emphasizing student learning and digital resources over managing the formerly paper-based archive of human knowledge.
- **Open space and TDM:** Similar to the Immediate project focus, improvements to open space and TDM should be developed.

Figure 107. Funding Proportion: Focus Area B

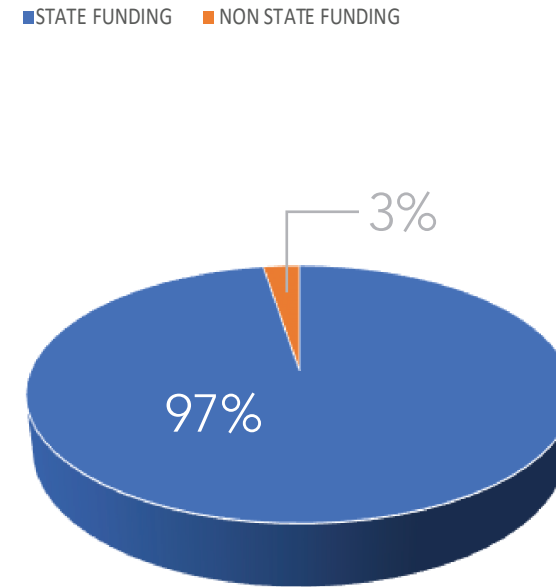


Table 26. Area and Cost Estimation: Focus B

Funding	Space Type / Project	Rounded Cost per Unit	Area / Beds / Units	Cost	No Escalation Included
State	Science Laboratory Building	\$918	92,000 GSF	\$84,500,000	\$84,500,000
State	Renovation	\$343	280,000 GSF	\$96,000,000	\$96,000,000
State	New Academic Space	\$955	157,000 GSF	\$150,000,000	\$150,000,000
State	Renovation	\$844	125,600 GSF	\$106,000,000	\$106,000,000
State	Renovation	\$466	147,000 GSF	\$68,500,000	\$68,500,000
State	Renovation	\$427	141,600 GSF	\$60,500,000	\$60,500,000
State	Renovation	\$448	145,000 GSF	\$65,000,000	\$65,000,000
State	Open Space	\$85	200,000 GSF	\$17,000,000	\$17,000,000
Non State	Open Space	\$85	200,000 GSF	\$17,000,000	\$17,000,000
				<b>STATE FUNDING</b>	<b>\$647,500,000</b>
				<b>NON STATE FUNDING</b>	<b>\$17,000,000</b>
				<b>TOTAL PER FOCUS AREA</b>	<b>\$664,500,000</b>

Figure 106. Plan: Focus Area B





## FOCUS AREA C: RESIDENCY

Goal: A key initiative for success is student persistence and support of the Graduation Initiative 2025. A fundamental component to this is to move the campus from a commuter to a residential campus, where an increased number of freshman and sophomore students can live on campus, develop strong peer support and study groups, and focus on block scheduling early in their time on campus. The addition of 2,400 bed units, taking the campus to approximately 5,000 beds (approximately 10% of the main campus student headcount based on the projections outlined in the Enrollment Section on page 42) will be the focus of this initiative. Combined with 350 faculty housing units and student life amenities, the campus will have a vibrant living learning community.

### Projects:

- 2,400 Student bed units: Additional options for students housing on campus improves the development of the active community. Providing an alternate housing district with a new character drives diversity and the possibility for alternate cohorts. Located next to State College Boulevard, the development scale will step down towards the neighboring community housing to reduce the visual impact.
- 350 faculty/ staff housing units: Located on the College Park parcel, the faculty/ staff housing will be a blend of 1, 2 and 3 bed units. Integrating mixed use on the ground level it is envisaged these units could be occupied by the general public if the University does not fully occupy all units.

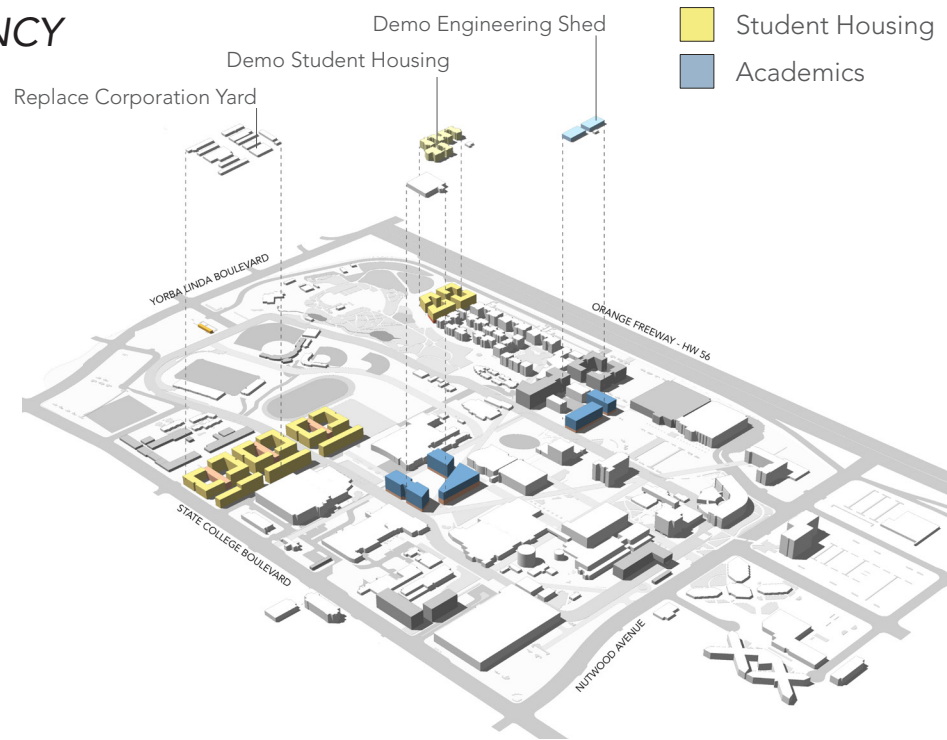


Figure 108. Massing Model: Focus Area C

- Student Life Amenities: Additions to the Student Union, health and wellness facilities, exercise options and recreational facilities, along with retail options support students remaining on campus and building community.
- Addition of academic space: With the increase in FTEs, the addition of new academic space will provide additional capacity. Replacing outmoded and aging facilities will also add contemporary teaching environments.
- Mobility Hubs: In tandem with the TDM strategy, the three mobility hubs provide enhanced access options to campus supporting the increased campus population.
- Open space and TDM: Similar to the Immediate project focus, improvements to open space and TDM should be developed.

Figure 109. Plan: Focus Area C

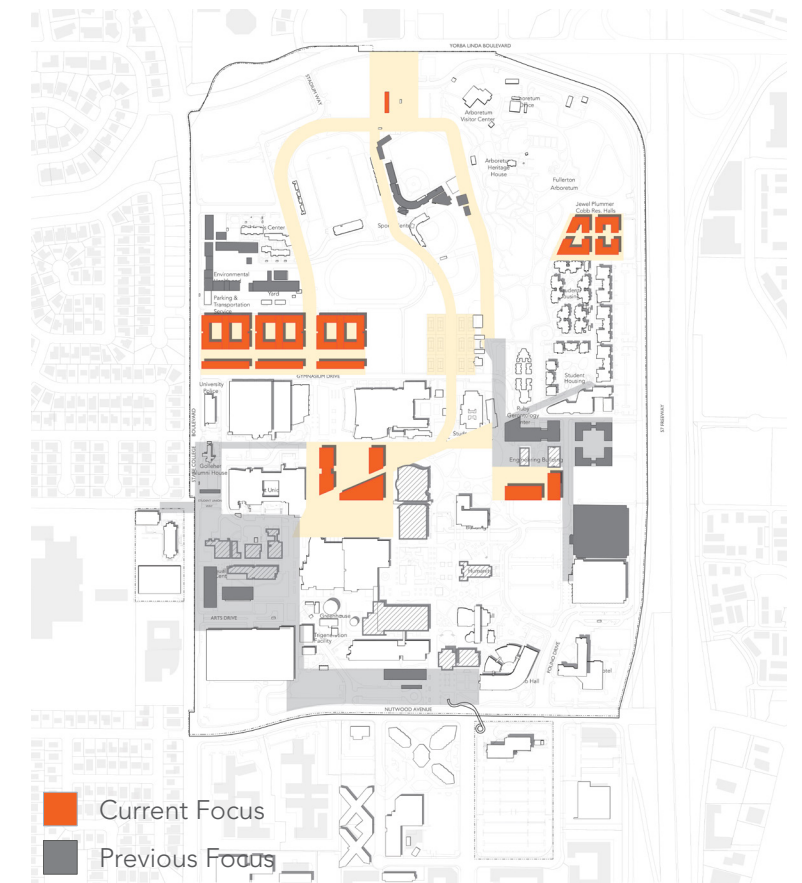


Figure 110. Funding Proportion: Focus Area C

■ STATE FUNDING ■ NON STATE FUNDING

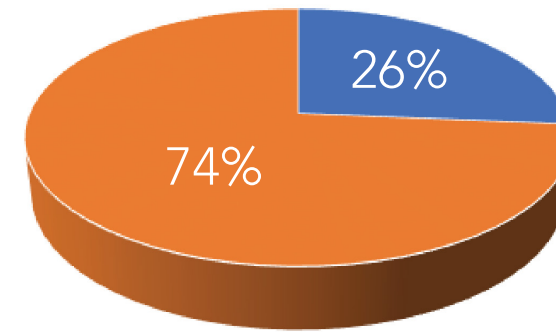


Table 27. Area and Cost Estimation: Focus C

Funding	Space Type / Project	Rounded Cost per Unit	Area / Beds / Units	Cost	5%/year to Mid Point Escalation
Non State	New Student Housing	\$87,928	2,400 beds	\$211,027,200	\$506,465,280
Non State	New Campus Amenities	\$539	266,000 GSF	\$143,437,840	\$344,250,816
Non State	New Faculty/ Staff Housing	\$133,499	350 units	\$46,724,650	\$112,139,160
State	New Academic Space	\$676	194,000 GSF	\$131,144,000	\$314,745,600
State	Renovation	\$466	7,200 GSF	\$1,260,000	\$3,024,000
State	Renovation	\$427	233,333 GSF	\$19,833,305	\$47,599,932
State	Renovation	\$448	233,333 GSF	\$19,833,305	\$47,599,932
				<b>STATE FUNDING</b>	<b>\$362,345,532</b>
				<b>NON STATE FUNDING</b>	<b>\$1,013,479,188</b>
				<b>TOTAL PER FOCUS AREA</b>	<b>\$1,375,824,720</b>



## FOCUS AREA D: COMMUNITY

Goal: Community building as part of an active campus strategy to support academic outcomes is key. Providing facilities that create opportunities for town and gown interactions, on campus activities such as commencement, cultural events, exhibits and trade shows will all contribute to creating a sense of place and environment where the goal is for all campus stakeholders to remain and engage with each other on campus.

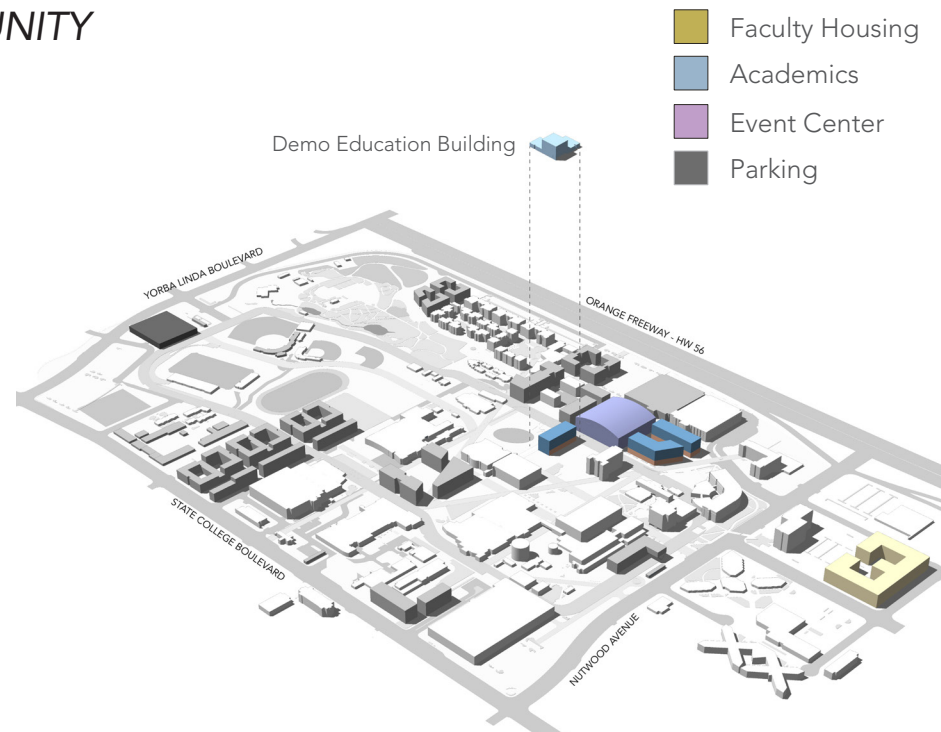


Figure 111. Massing Model: Focus Area D

### Projects:

- **Event Center:** A 6,000-seat Event Center located in the academic core will provide space for athletics, intramural sports, community events and student activities. Envisaged as a constantly active hub, the Event Center additionally engages with the surrounding open space.
- **Arboretum Facilities:** A unique and loved asset of campus, contributing to both health and wellness along with academic programs, the Arboretum will remain a strong contributor to promoting community within campus and with the surrounding neighborhoods. This master plan anticipates upgrades to existing facilities and the provisions of functions in support of the arboretum mission.
- **North side garage:** As campus growth adds the demand for

parking, additional parking structures will be assessed and added in the northern portion of campus. Exact timing and space counts will be influenced by population changes and implemented TDM strategies.

- **Student Life facilities:** Additions to the Student Union, health and wellness facilities, exercise options and recreational facilities, along with retail options support students remaining on campus and building community.
- **Addition of academic space:** With the increase in FTEs, the addition of new academic space will provide additional capacity. Replacing outmoded and aging facilities will also add contemporary teaching environments.
- **Open space and TDM:** Similar to the immediate project focus, improvements to open space and TDM should be developed.

Figure 113. Funding Proportion: Focus Area D

STATE FUNDING NON STATE FUNDING

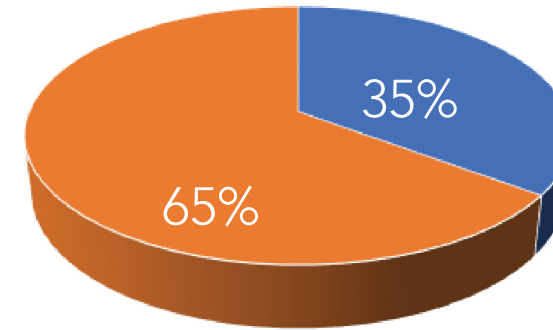


Figure 112. Plan: Focus Area D

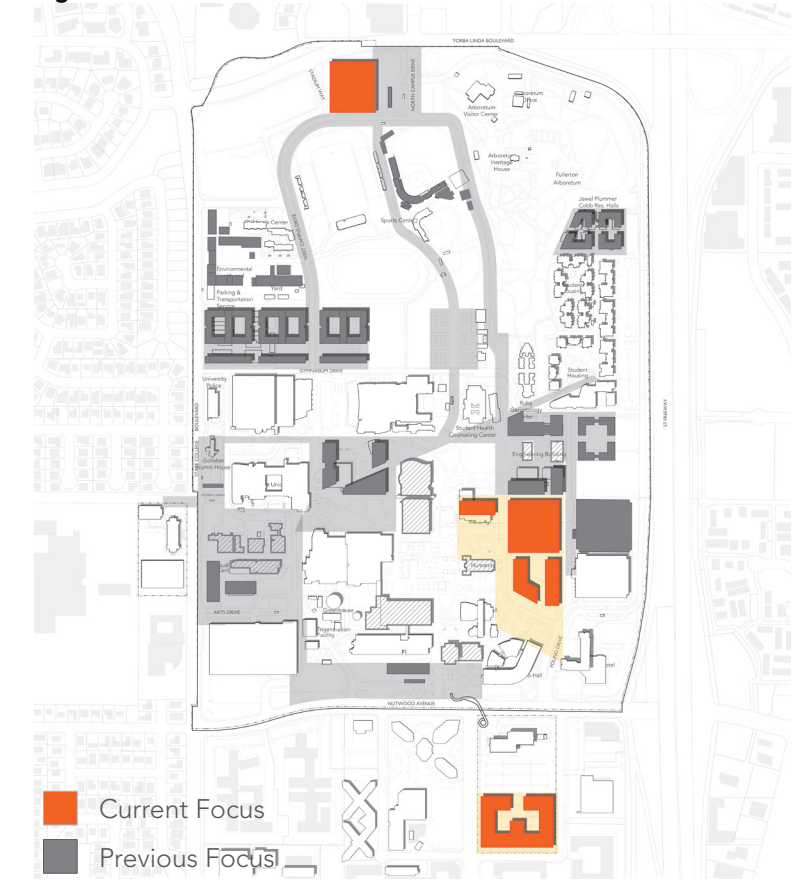


Table 28. Area and Cost Estimation: Focus D

Funding	Space Type / Project	Rounded Cost per Unit	Area / Beds / Units	Cost	5%/year to Mid Point Escalation
Non State	New Campus Amenities	\$539	266,000 GSF	\$143,437,840	\$344,250,816
State	New Academic Space	\$676	194,000 GSF	\$131,144,000	\$314,745,600
Non State	New Non Academic	\$379	40,000 GSF	\$15,147,600	\$36,354,240
Non State	New Facilities in Arboretum	\$480	100,000 GSF	\$48,001,000	\$115,202,400
Non State	New Event Center	\$684	254,100 GSF	\$173,707,842	\$416,898,821
Non State	New Parking Structure	\$18,843	2,236 GSF	\$42,132,948	\$101,119,075
State	Demolition	\$67	108,319 GSF	\$7,203,214	\$17,287,712
State	Replacement of Existing	\$676	108,319 GSF	\$73,223,644	\$175,736,746
State	Open Space	\$85	233,333 GSF	\$19,833,305	\$47,599,932
Non State	Open Space	\$85	233,333 GSF	\$19,833,305	\$47,599,932
State	Demo part of KHS	\$67	131,732 GSF	\$8,826,044	\$21,182,506
				<b>STATE FUNDING</b>	<b>\$576,552,496</b>
				<b>NON STATE FUNDING</b>	<b>\$1,061,425,284</b>
				<b>TOTAL PER FOCUS AREA</b>	<b>\$1,637,977,780</b>



## FOCUS AREA E: PEDAGOGY

Goal: Central to the University's mission is how to academically engage students, creating opportunities and preparing them for the future. The addition of entitled academic space to support teaching and learning, together with student-directed research is part of this approach. The notion of interdisciplinary collaboration across Colleges is another focus that the Physical Master Plan looks to address. Informal learning is embedded within the academic buildings, residential housing, and in the open campus environment so that the whole campus becomes a living learning community.

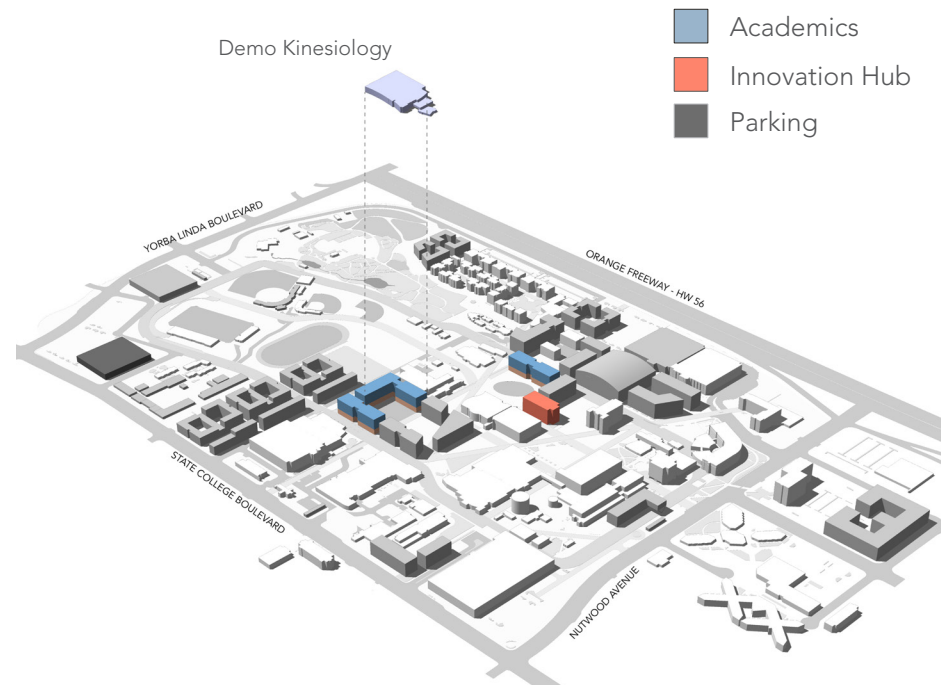


Figure 114. Massing Model: Focus Area E

### Projects

- Innovation Center: Central to cross collaboration, the Innovation Center has close ties to the Library, embracing the LOFT strategy outlined in the library renovation.
- Student Life facilities: Additions to the Student Union, health and wellness facilities, exercise options and recreational facilities, along with retail options support students remaining on campus; brings relief from study and builds community.
- Addition of academic space: With the increase in FTEs, the addition of new academic space will provide additional capacity. Replacing outmoded and aging facilities will also add contemporary teaching environments.
- Open space and TDM: Similar to the Immediate project focus, improvements to open space and TDM should be developed.

Figure 116. Funding Proportion: Focus Area E

■ STATE FUNDING ■ NON STATE FUNDING

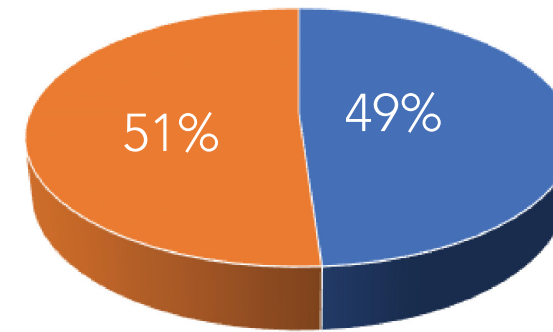


Figure 115. Plan: Focus Area E

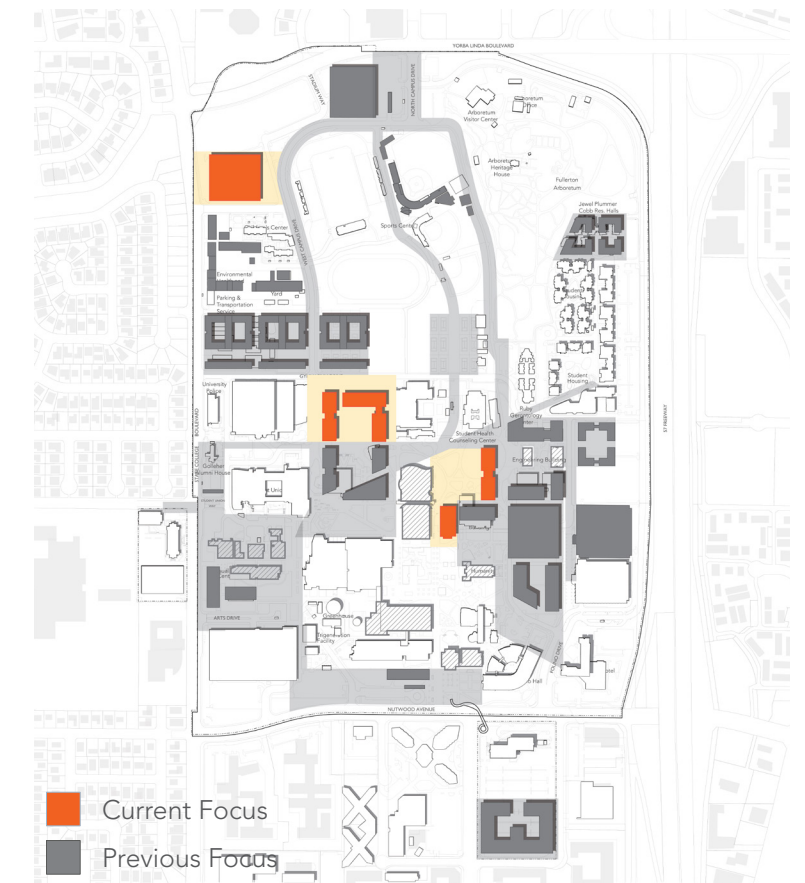


Table 29. Area and Cost Estimation: Focus E

Funding	Space Type / Project	Rounded Cost per Unit	Area / Beds / Units	Cost	5%/year to Mid Point Escalation
Non State	New Campus Amenities	\$539	266,000 GSF	\$143,437,840	\$344,250,816
State	New Academic Space	\$676	194,000 GSF	\$131,144,000	\$314,745,600
Non State	New Innovation Center	\$499	73,090 GSF	\$36,447,059.40	\$87,472,943
Non State	New Parking Structure	\$18,843	2,236 GSF	\$42,132,948	\$101,119,075
State	Demolition	\$67	108,319 GSF	\$7,203,214	\$17,287,712
State	Replacement of Existing	\$676	108,319 GSF	\$73,223,644	\$175,736,746
State	Open Space	\$85	233,333 GSF	\$19,833,305	\$47,599,932
Non State	Open Space	\$85	233,333 GSF	\$19,833,305	\$47,599,932
				<b>STATE FUNDING</b>	<b>\$555,369,990</b>
				<b>NON STATE FUNDING</b>	<b>\$580,442,766</b>
				<b>TOTAL PER FOCUS AREA</b>	<b>\$1,135,812,756</b>



